

Powered Industrial Trucks - Operator Training



1910.178 (1)

1915.120 (a)

1917.1 (a)(2)(xiv)

1918.1 (b)(10)

1926.602 (d)

Disclaimer

- This presentation is intended as a resource for providing training on OSHA's revised powered industrial truck operator standards. It is not a substitute for any of the provisions of the Occupational Safety and Health Act of 1970, or for any standards issued by the U.S. Department of Labor's Occupational Safety and Health Administration (OSHA). **It is also not a substitute for a powered industrial truck operator training program.**

Acknowledgment

- OSHA's Office of Training and Education wishes to acknowledge the following for contributing some of the graphics used in this presentation:
 - Caterpillar Lift Trucks
 - Mason Contractors Association of America
 - Industrial Truck Association
 - State of Utah Labor Commission - Occupational Safety & Health Division
 - Steamship Trade Association of Baltimore
 - Taylor Machine Works, Inc.
 - UAW - Ford National Joint Committee on Health and Safety
- Appearance of products does not imply endorsement by the U.S. Department of Labor.

Powered Industrial Truck - Definition



- A mobile, power-propelled truck used to carry, push, pull, lift, stack or tier materials. [American Society of Mechanical Engineers (ASME) definition]
- Excluded are vehicles used for earth moving and over-the-road hauling.
- Commonly known as forklifts, pallet trucks, rider trucks, forktrucks, or liftrucks.
- Can be powered through electric or combustion engines.

Scope of Standard

- The scope provisions of 1910.178(a), which are based on ANSI B56.1 - 1969, remain in effect and cover:
 - ... fork trucks, tractors, platform lift trucks, motorized hand trucks, and other specialized industrial trucks powered by electric motors or internal combustion engines.
 - It does not apply to compressed air or nonflammable compressed gas-operated industrial trucks, farm vehicles, nor vehicles intended primarily for earth moving or over-the-road hauling.
- This scope covers general industry, construction and shipyards.

Scope of Standard (continued)

- For marine terminal and longshoring industries, all powered industrial trucks are covered, no matter what specialized name they are given.
- This includes, but is not limited to, straddle carriers, hustlers, toploaders, container reach stackers, and other vehicles that carry, push, pull, lift, or tier loads.

Reasons for New Standard

- Powered industrial truck accidents cause approximately 100 fatalities and 36,340 serious injuries in general industry and construction annually.
- It is estimated that 20 - 25% of the accidents are, at least in part, caused by inadequate training.

Additional Reasons for New Standard

- Updated consensus standards have been published.
- OSHA has been petitioned to improve the requirements for industrial truck training.
- Advisory Committee on Construction Safety and Health has recommended improving the standard.
- Resolutions have been introduced in the Senate and House urging OSHA to revise its outdated standard.

Forklift Fatalities, 1992-1996

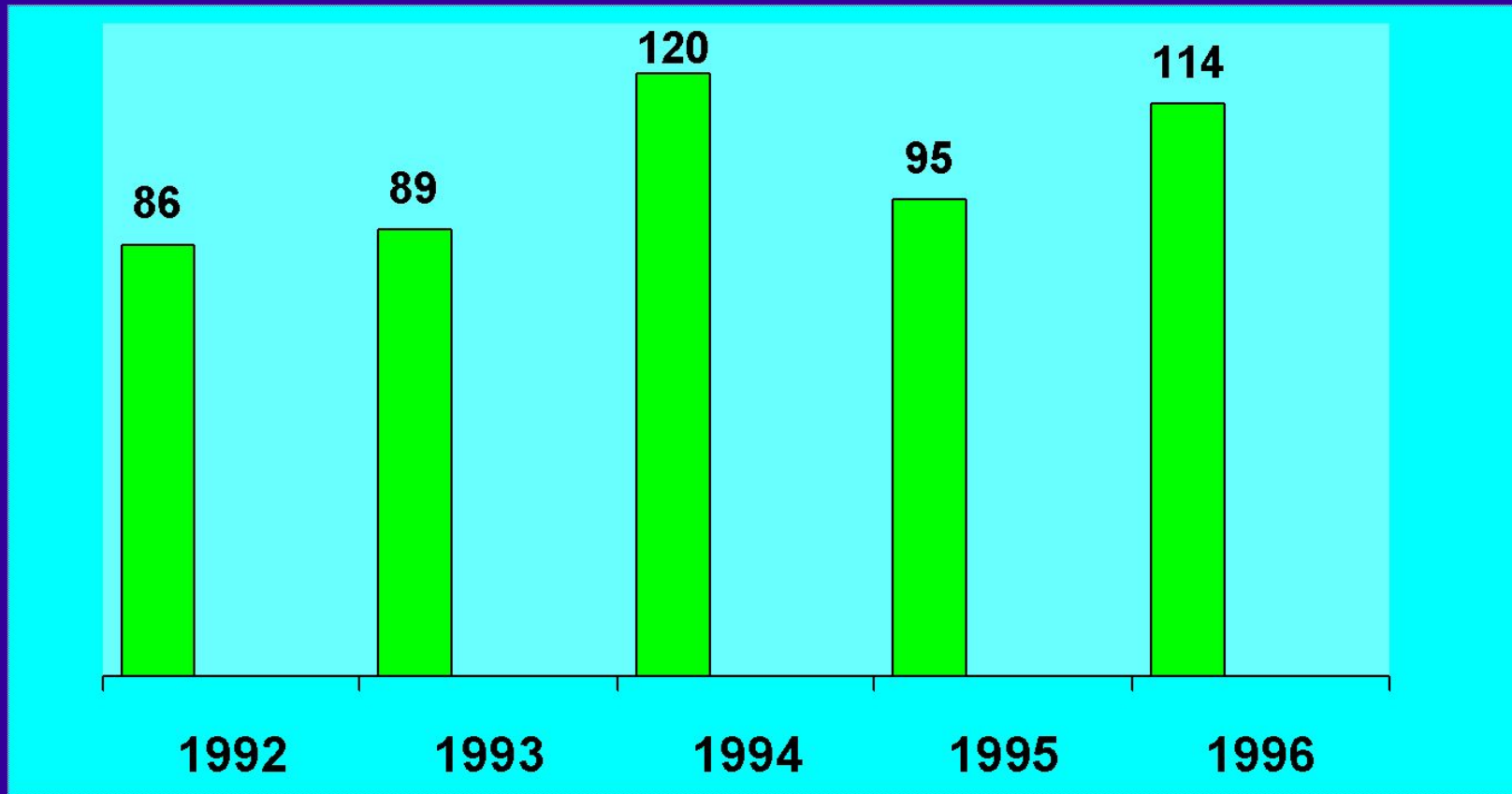

Source: Bureau of Labor Statistics, Job Related Fatalities Involving Forklifts

Forklift Fatalities by Age Group 1992 -1996

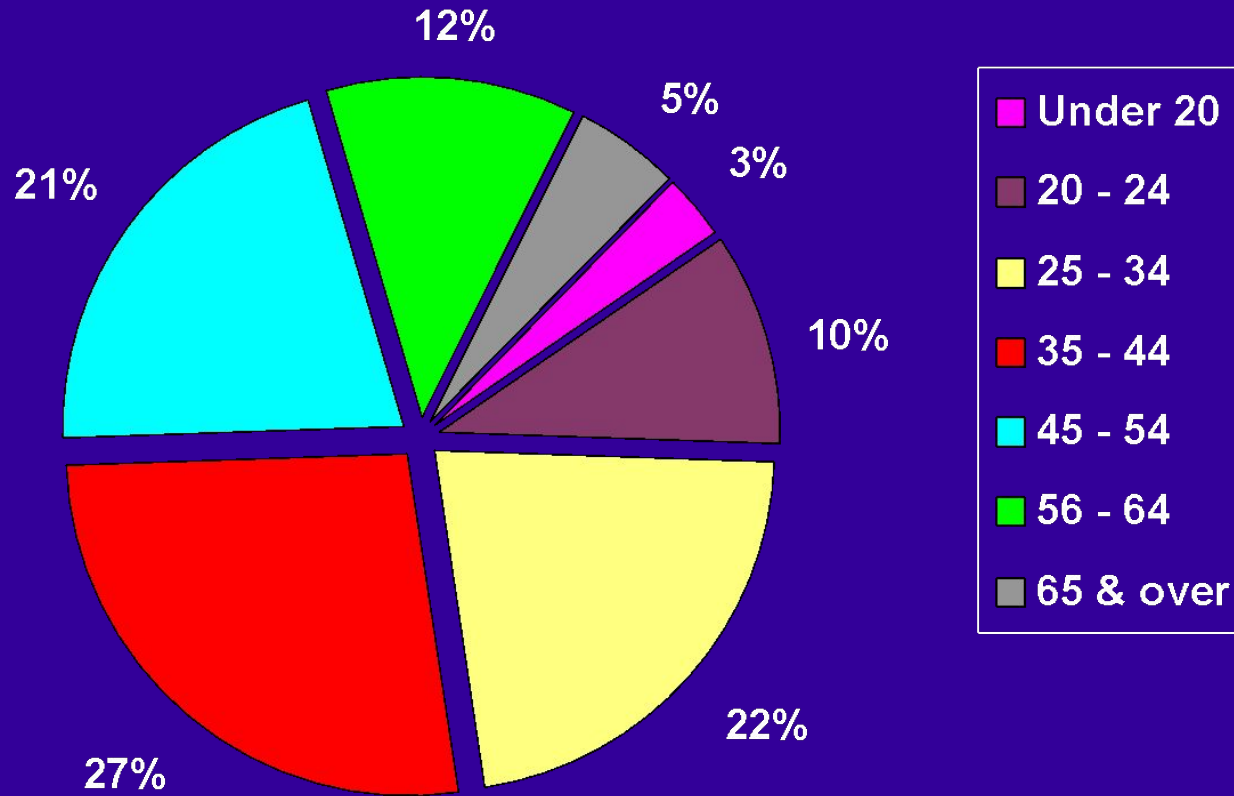

Source: Bureau of Labor Statistics

Industries Where Powered Industrial Truck Accidents Occurred

Industry	# Accidents Investigated by OSHA
Mining	4
Construction	25
Manufacturing	95
Transportation, Communication, Utilities	22
Wholesale Trades	25
Retail Trades	18
Service	7
Public Administration	4
Total	200

Source: OSHA Fatality/Catastrophe Reports, compiled by OSHA Office of Electrical/Electronic and Mechanical Engineering Safety Standards.

Nonfatal Occupational Injuries and Illnesses by Source, 1996

Type of Forklift	Total Cases
Forklift, unspecified	14,096
Hand/rider forklift truck	373
Order picker	126
Pallet lift truck	1,194
Platform lift truck	260
Straddle rider lift truck	131
Forklift, other types	1,182
TOTAL	17,362

Source: Bureau of Labor Statistics, Job Related Fatalities by Selected Characteristics, 1996.

Background

- The previous OSHA standards, while requiring operator training, did not define the type of training or authorization required.
- March 15, 1988 - Industrial Truck Association (ITA) petitioned OSHA for specific training requirements.

Background (continued)

- American National Standards Institute (ANSI), in cooperation with ASME, has revised its standard 4 times, including current lifttruck technology and specific training topics.

Background (continued)

- OSHA published a proposed ruling on March 14, 1995 for General Industry, Shipyard, Marine Terminals, and Longshoring regulations, adding specific training requirements.
- On January 30, 1996, OSHA proposed a revision of the construction standards, mandating the development of an operator training program based on the prior knowledge and skills of the trainee and requiring a periodic evaluation.

Final Rule

- OSHA published the final rule for Powered Industrial Truck Operator Training on December 1, 1998.
- The effective date is March 1, 1999. Start-up dates are included in paragraph (1)(7).
- It applies to all industries except agricultural operations.
- OSHA estimates that the new rule will prevent 11 deaths and 9,422 injuries per year.

Fatalities/Injuries Potentially Averted Annually by New Standard

Sector	# Fatalities	Estimated # Fatalities Averted	# Injuries	Estimated # Injuries Averted
Agriculture	0	0	47	5
Mining	1	0	0	0
Construction	16	2	2,380	237
Manufacturing	35	4	44,976	4,481
Transportation	16	2	10,698	1,066
Longshoring & Marine Terminals	3	0	275	27
Wholesale & Retail Trade	23	2	31,649	3,153
Finance, Insurance & Real Estate	0	0	79	8
Services	7	1	4,466	445
All Covered Industries	101	11	94,570	9,422

Performance-Oriented Requirements

- The powered industrial truck operator training requirements are performance-oriented to permit employers to tailor a training program to the characteristics of their workplaces and the particular types of powered industrial trucks operated.

Revised Operator Training Requirements

- **General Industry:** 1910.178 is amended by revising paragraph (1) and adding Appendix A.
- **Shipyard Employment:** New section 1915.120 and Appendix A are added.
- **Marine Terminals:** Section 1917.1 is amended by adding new paragraph (a)(2)(xiv) and Appendix A.
- **Longshoring:** Section 1918.1 is amended by adding new paragraph (b)(10) and Appendix A.
- **Construction:** 1926.602 is amended by adding new paragraph (d) and Appendix A.

Operator Training

- Safe operations
 - The employer shall ensure that each powered industrial truck operator is competent to operate a powered industrial truck safely, as demonstrated by successful completion of the training and evaluation specified in the OSHA standard.
 - Prior to permitting an employee to operate a powered industrial truck (except for training purposes), the employer shall ensure that each operator has successfully completed the required training (or previously received appropriate training).

Training Program Implementation

- Trainees may operate a powered industrial truck only:
 - Under direct supervision of a person who has the knowledge, training, and experience to train operators and evaluate their competence; and,
 - Where such operation does not endanger the trainee or other employees.

Training Program Implementation

(continued)

- Training shall consist of a combination of:
 - Formal instruction (e.g., lecture, discussion, interactive computer learning, written material),
 - Practical training (demonstrations and exercises performed by the trainee), and
 - Evaluation of the operator's performance in the workplace

Training Program Implementation (continued)

- Training and evaluation shall be conducted by a person with the knowledge, training and experience to train powered industrial truck operators and evaluate their competence.



Training Program Content

- Operators shall receive initial training in the following topics, except in topics which the employer can demonstrate are not applicable to safe operation in the employer's workplace.
 - Truck-related topics
 - Workplace-related topics
 - The requirements of the standard

Training Program Content (continued)

- Truck-related topics
 - Operating instructions, warnings and precautions
 - Differences from automobile
 - Controls and instrumentation
 - Engine or motor operation
 - Steering and maneuvering
 - Visibility
 - Fork and attachment adaptation, operation, use
 - Vehicle capacity and stability
 - Vehicle inspection and maintenance that the operator will be required to perform
 - Refueling/Charging/Recharging batteries
 - Operating limitations
 - Other instructions, etc.

Training Program Content (continued)

- Workplace-related topics
 - Surface conditions
 - Composition and stability of loads
 - Load manipulation, stacking, unstacking
 - Pedestrian traffic
 - Narrow aisles and restricted areas
 - Operating in hazardous (classified) locations
 - Operating on ramps and sloped surfaces
 - Potentially hazardous environmental conditions
 - Operating in closed environments or other areas where poor ventilation or maintenance could cause carbon monoxide or diesel exhaust buildup

Training Program Content (continued)

- The requirements of the OSHA standard on powered industrial trucks must also be included in the initial operator training program.

Refresher Training and Evaluation

- Refresher training, including an evaluation of the effectiveness of that training, shall be conducted to ensure that the operator has the knowledge and skills needed to operate the powered industrial truck safely.
- Refresher training required when:
 - Unsafe operation
 - Accident or near-miss
 - Evaluation indicates need
 - Different type of equipment introduced
 - Workplace condition changes

Refresher Training and Evaluation

(continued)

- An evaluation of each powered industrial truck operator's performance must be conducted:
 - After initial training,
 - After refresher training, and
 - At least once every three years

Avoidance of Duplicative Training

- If an operator has previously received training in a topic specified in this section, and the training is appropriate to the truck and working conditions encountered, additional training in that topic is not required if the operator has been evaluated and found competent to operate the truck safely.

Certification

- The employer shall certify that each operator has been trained and evaluated as required by the standard.
- Certification shall include:
 - Name of operator
 - Date of training
 - Date of evaluation
 - Identity of person(s) performing the training or evaluation

Dates

- The employer shall ensure that operators of powered industrial trucks are trained, as appropriate, by the dates shown in the following table.

If the employee was hired:	The initial training and evaluation of that employee must be completed:
Before December 1, 1999	By December 1, 1999
After December 1, 1999	Before the employee is assigned to operate a powered industrial truck.

Appendix A - Stability of Powered Industrial Trucks

- Appendix A provides non-mandatory guidance to assist employers in implementing the standard.
- This appendix does not add to, alter, or reduce the requirements of this section.

Appendix A - Stability of Powered Industrial Trucks

- Definitions
- General
- Basic Principles
- Stability Triangle
- Longitudinal Stability
- Lateral Stability
- Dynamic Stability



Stability Triangle - Figure 1

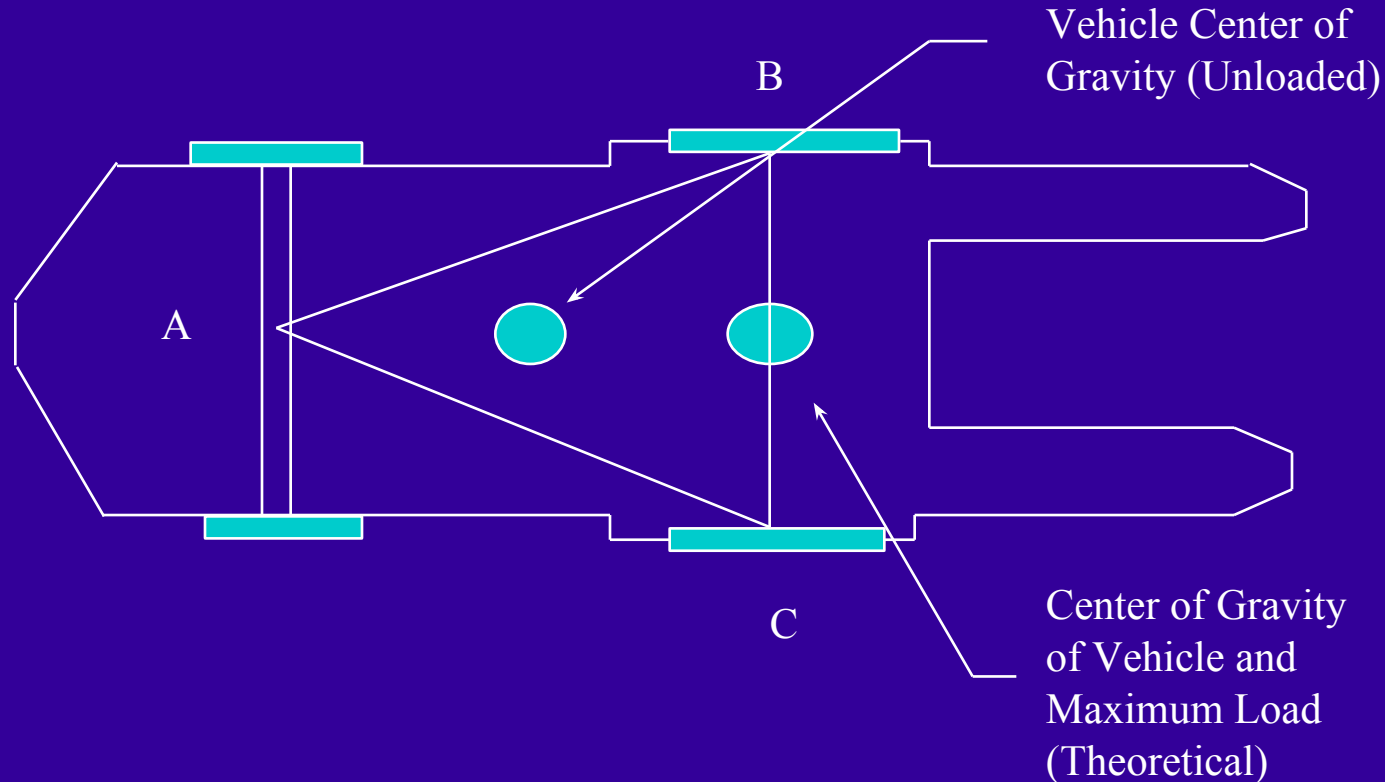

Notes:

1. When the vehicle is loaded, the combined center of gravity (CG) shifts toward line B-C. Theoretically the maximum load will result in the CG at the line B-C. In actual practice, the combined CG should never be at line B-C.
2. The addition of additional counterweight will cause the truck CG to shift toward point A and result in a truck that is less stable laterally.

Stability Triangle - Figure 2

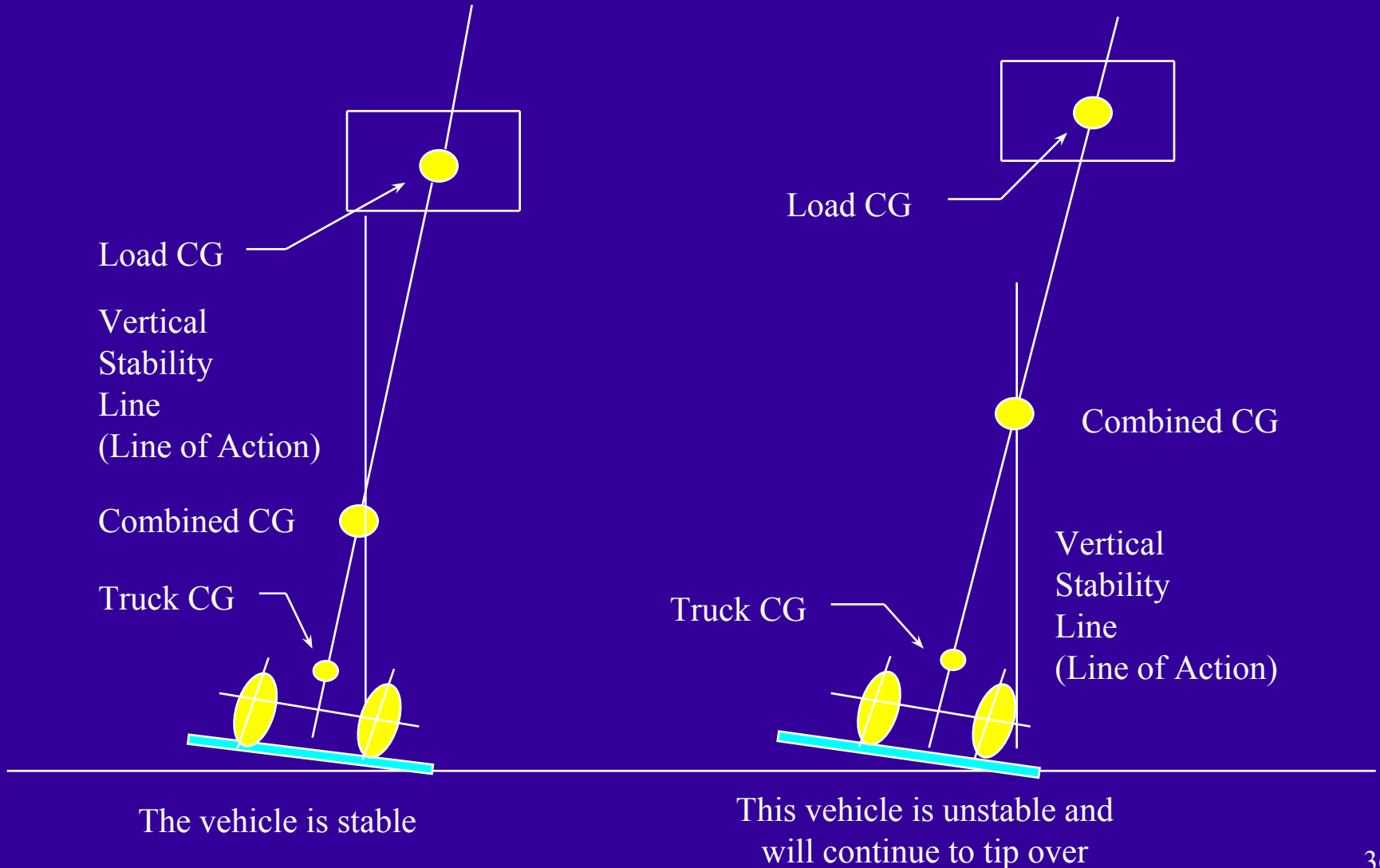

Effective Powered Industrial Truck Operator Training Program

- Four major areas of concern must be addressed:
 - The general hazards that apply to the operation of all or most powered industrial trucks;
 - The hazards associated with the operation of particular types of trucks;
 - The hazards of workplaces generally; and,
 - The hazards of the particular workplace where the vehicle operates.

Types of Powered Industrial Trucks

- There are many different types of powered industrial trucks covered by the OSHA standard.
- Commonly used types include:
 - High lift trucks, counterbalanced trucks, cantilever trucks, rider trucks, forklift trucks, high lift trucks, high lift platform trucks, low lift trucks, motorized hand trucks, pallet trucks, straddle trucks, reach rider trucks, high lift order picker trucks, motorized hand/rider trucks, and counterbalanced front/side loader lift trucks.
- A single type of truck can only be described by calling it by all of its characteristics, (e.g., a high lift, counterbalanced, sit down rider truck).

Unique Characteristics of Powered Industrial Trucks

- Each type of powered industrial truck has its own unique characteristics and some inherent hazards.
- To be effective, training must address the unique characteristics of the type of vehicle the employee is being trained to operate.

Components of a Forklift Truck*

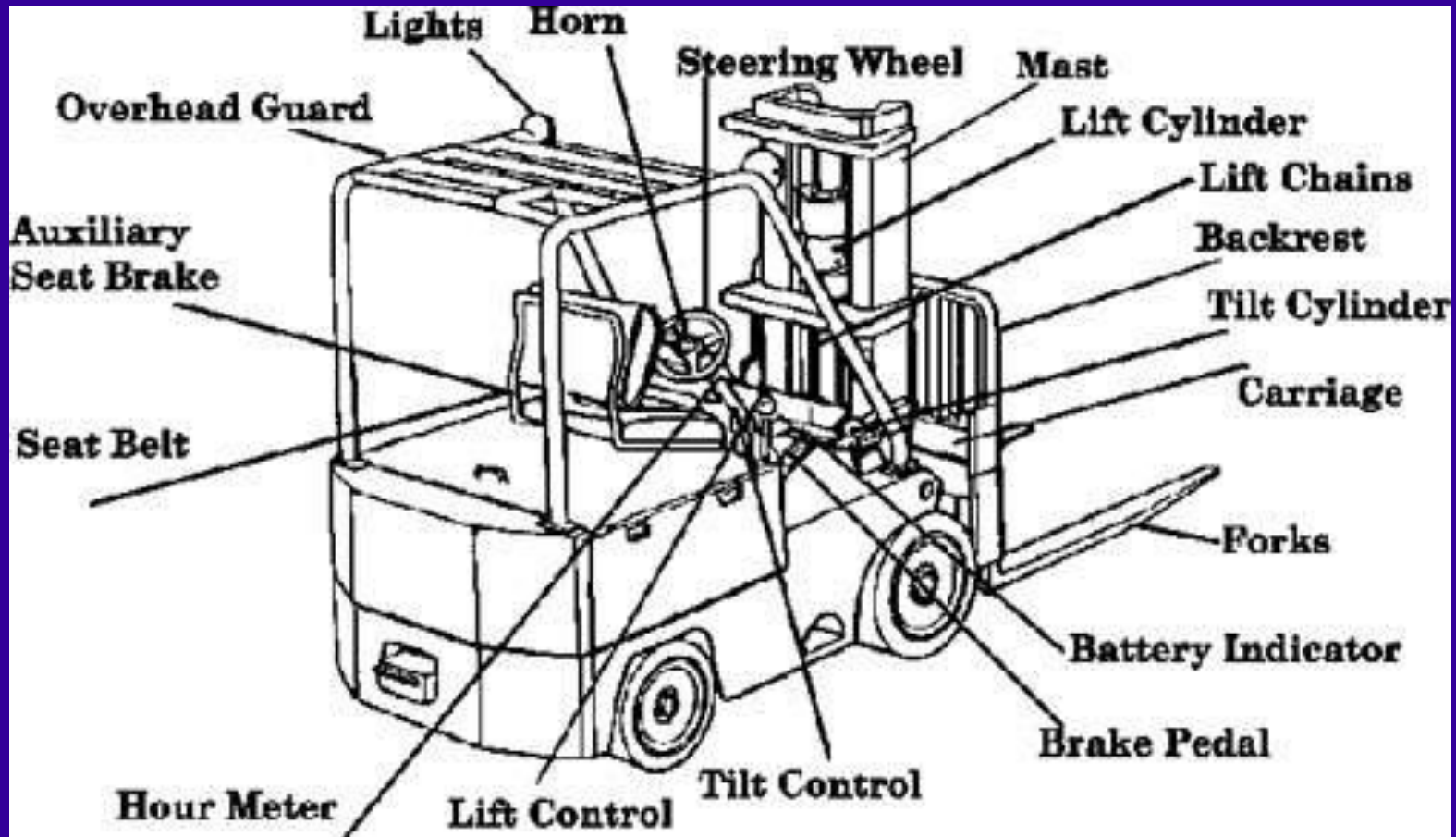

*One of the most common types of powered industrial trucks

Classes of Commonly-Used Powered Industrial Trucks*

- The Industrial Truck Association has placed powered industrial trucks into 7 classes.
 - Class I - Electric motor rider trucks
 - Class II - Electric motor narrow aisle trucks
 - Class III - Electric motor hand trucks or hand/rider trucks
 - Class IV - Internal combustion engine trucks (solid/cushion tires)
 - Class V - Internal combustion engine trucks (pneumatic tires)
 - Class VI - Electric and internal combustion engine tractors
 - Class VII - Rough terrain forklift trucks

* Note that this classification refers to commonly-used vehicles and does not include all powered industrial trucks covered by the OSHA standard.

Class I - Electric Motor Rider Trucks

- Counterbalanced rider type, stand up
- Three wheel electric trucks, sit-down
- Counterbalanced rider type, cushion tires, sit-down (high and low platform)
- Counterbalanced rider, pneumatic tire, sit-down (high and low platform)

Class I - Electric Motor Rider Trucks

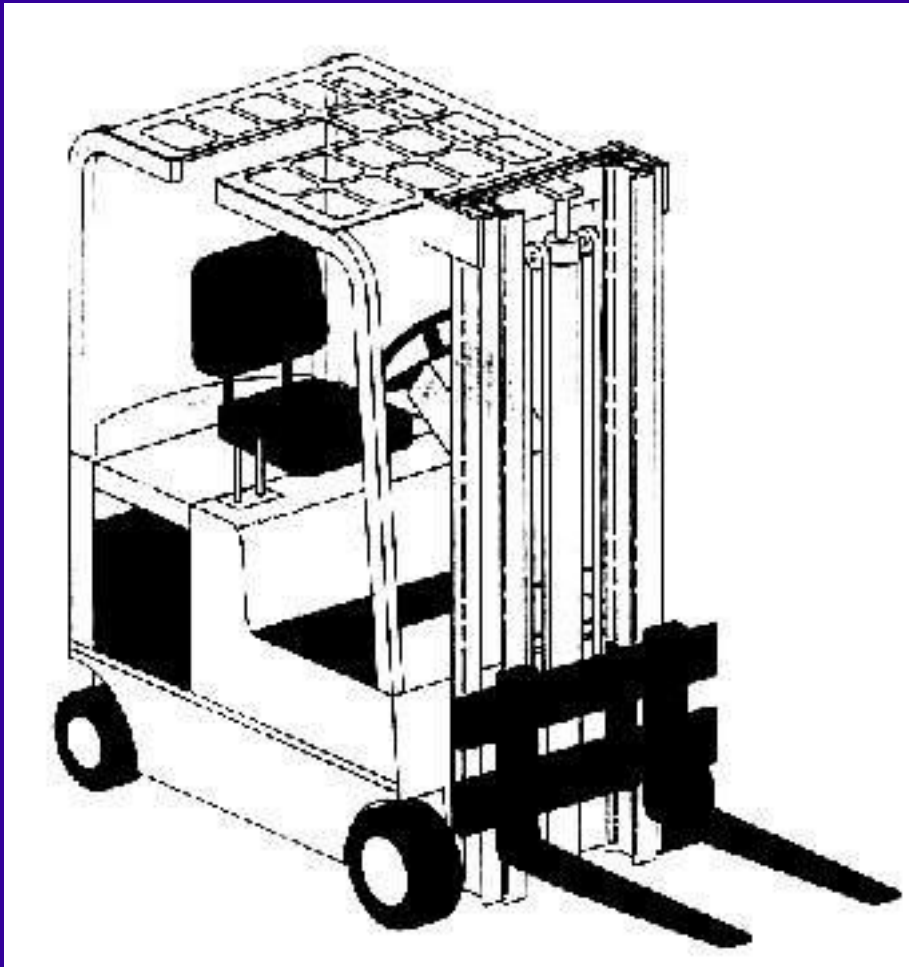

Sit Down Rider - Electric

Class I - Electric Motor Rider Trucks



- Counterbalanced Rider Type, Stand-Up

Class II - Electric Motor Narrow Aisle Trucks

- High lift straddle
- Order picker
- Reach type outrigger
- Side loaders, turret trucks, swing mast and convertible turret/stock pickers
- Low lift pallet and platform (rider)

Class II - Electric Motor Narrow Aisle Trucks

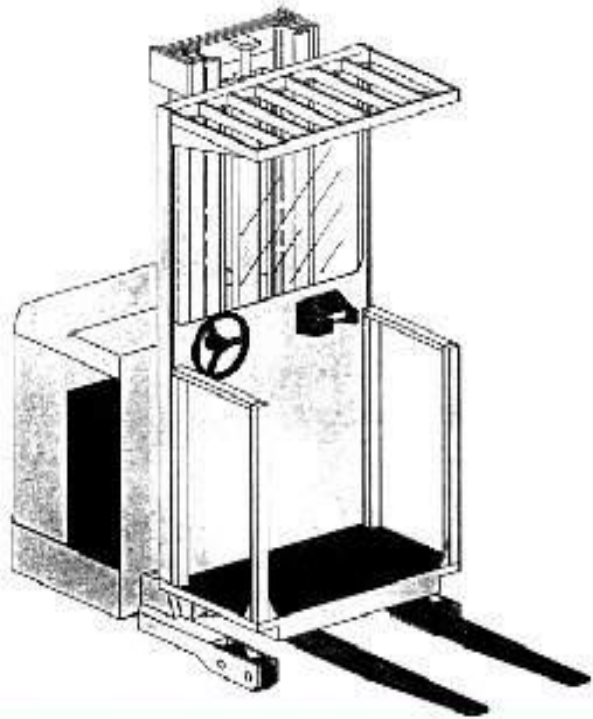

Order Picker

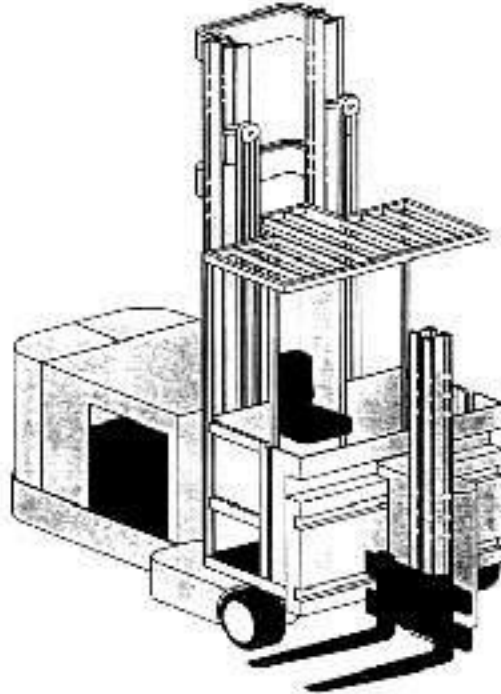

Turret Truck

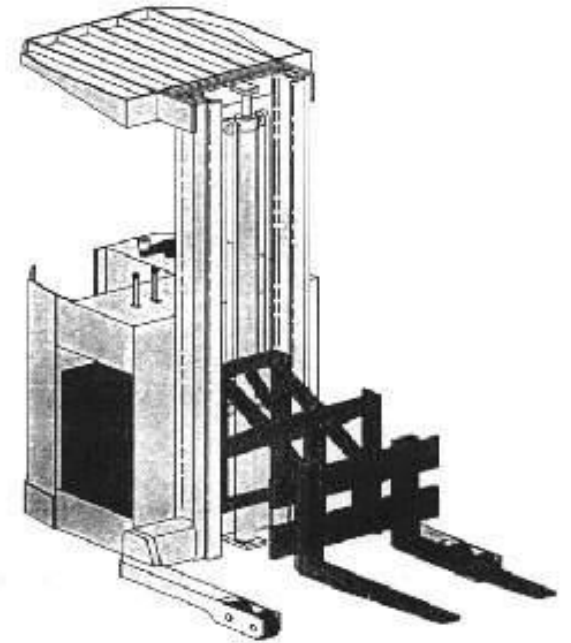

**Reach Type
Outrigger**

Class II - Narrow Aisle Trucks



Rider Reach Truck



Order Picker

Class III - Electric Motor Hand or Hand/Rider Trucks

- Low lift platform
- Low lift walkie pallet
- Reach type outrigger
- High lift straddle
- High lift counterbalanced
- Low lift walkie/rider pallet

Class III - Electric Motor Hand or Hand/Rider Trucks

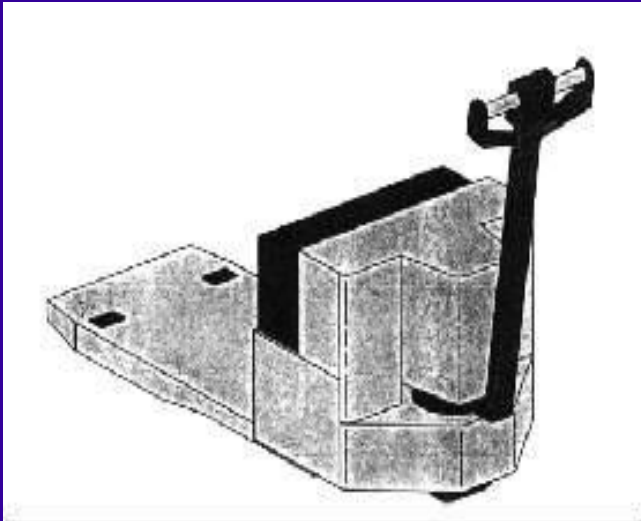

Low Lift Platform

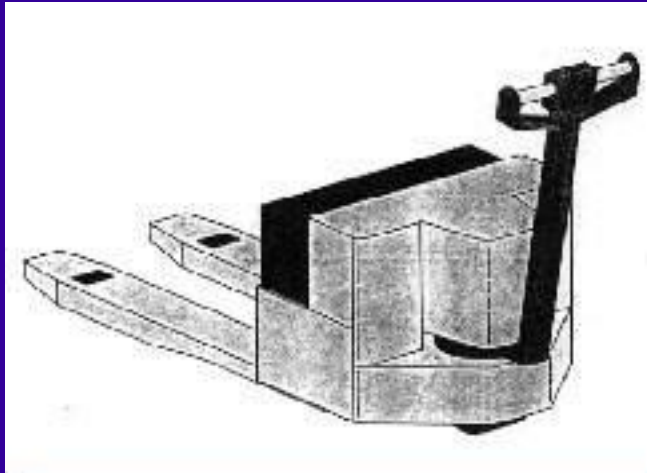

**Low Lift
Walkie Pallet**

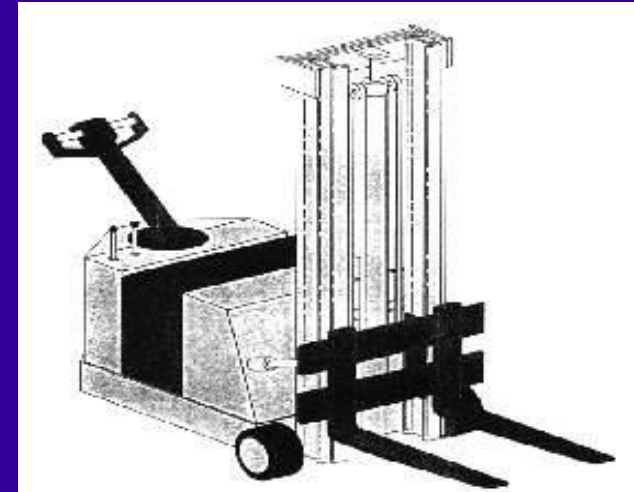

**High Lift
Counterbalanced**

Class III - Hand & Hand/Rider Trucks



**Walkie Powered
Pallet Truck**



**Walkie/Rider
Powered Pallet Truck**

Class IV - Internal Combustion Engine Trucks - Cushion (Solid) Tires

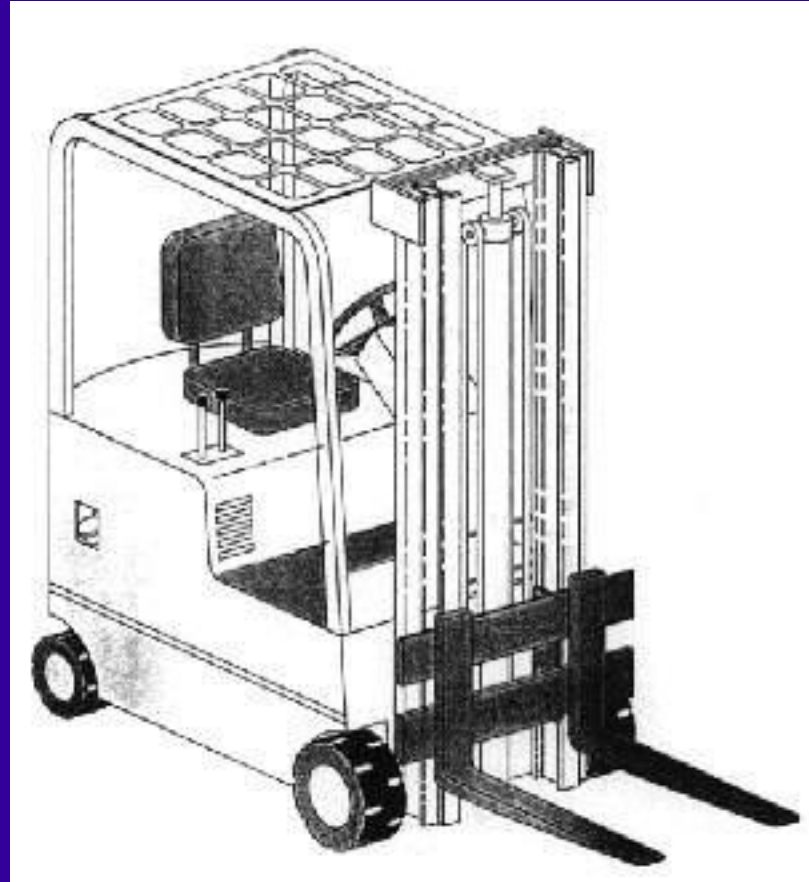

Fork, counterbalanced (cushion/solid tires)

Class IV - Internal Combustion Engine Trucks - Cushion (Solid) Tires



**Sit Down Rider Fork
- LPG**

Class V - Internal Combustion Engine Trucks - Pneumatic Tires

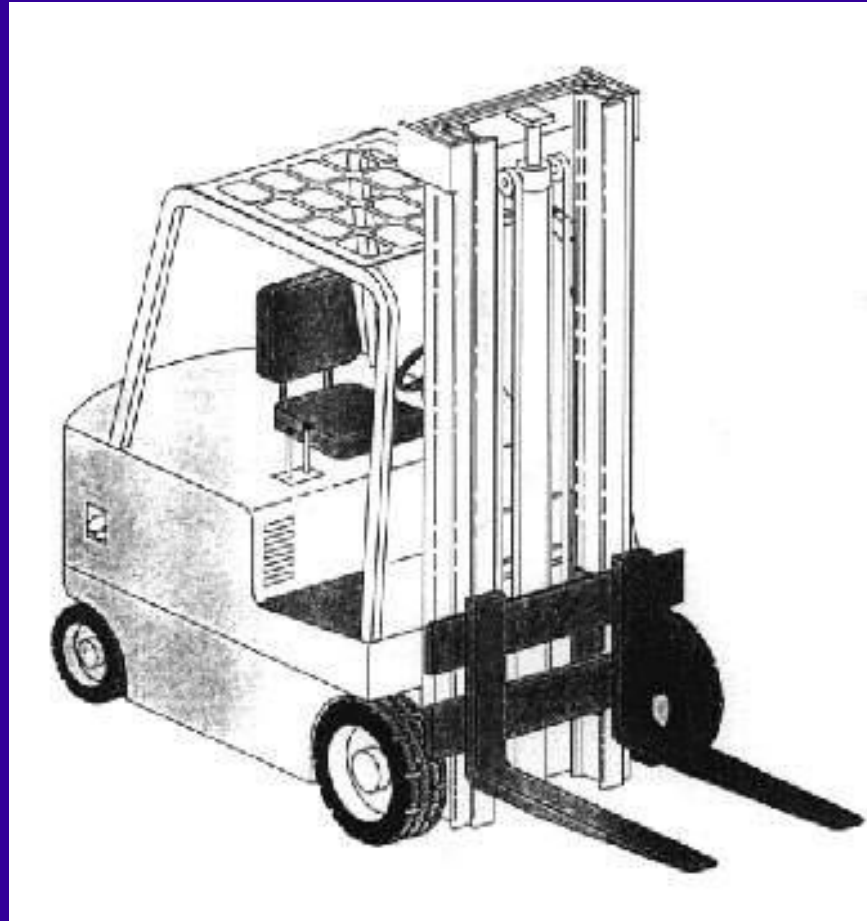

Fork, counterbalanced (pneumatic tires)

Class V - Internal Combustion Engine Trucks (Pneumatic Tires)



**Sit Down Rider - Gas-
Pneumatic Tires**

Class VI - Electric & Internal Combustion Engine Tractors

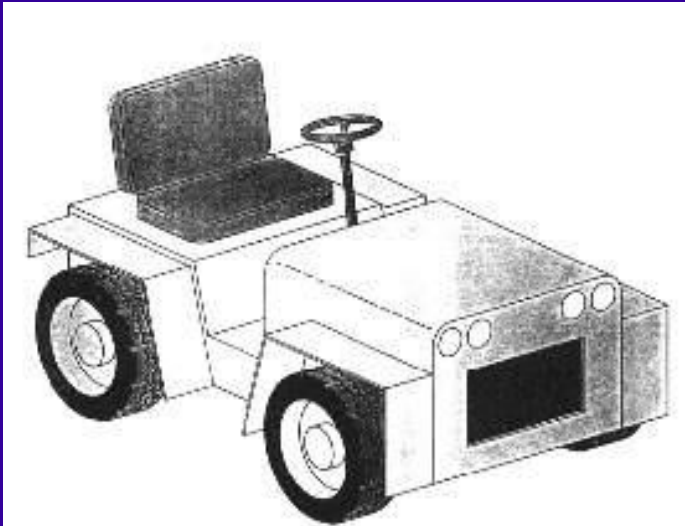

Sit-down rider

Class VII - Rough Terrain Forklift Trucks

- Straight-mast forklift



- Extended-reach forklift

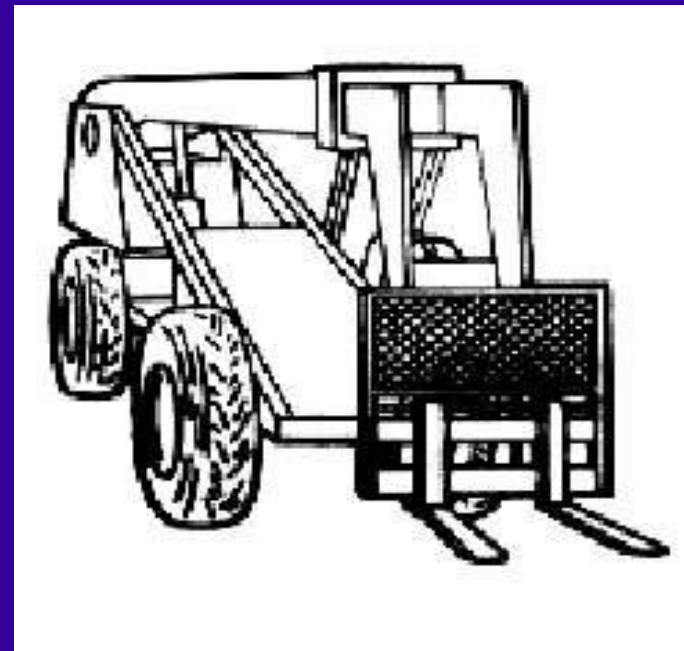

All rough terrain forklift trucks

Rough Terrain Straight Mast Forklifts



Rough Terrain Extended-Reach Forklifts



Some Types of Powered Industrial Trucks Used in Maritime

- The following types of vehicles are covered by the OSHA standard if the vehicles carry, push, pull, lift, or tier loads.
 - Container top handlers
 - Container reach stackers
 - Straddle carriers
 - Semi-tractors/ Utility vehicles
 - Sidehandlers
 - Combination vacuum lifts
 - Yard tractors

Powered Industrial Trucks Used in Maritime



Container Handlers

Powered Industrial Trucks Used in Maritime



Empty-Container Handler

Powered Industrial Trucks Used in Maritime



Container Reach Stacker

Powered Industrial Trucks Used in Maritime



Straddle Carriers



Powered Industrial Trucks Used in Maritime



Yard Tractor