

Homework Helpers

Grade 3 Module 4

Uppreth

G3-M4-Lesson 1

1. Vivian uses squares to find the area of a rectangle. Her work is shown below.

a. How many squares did she use to cover the rectangle?

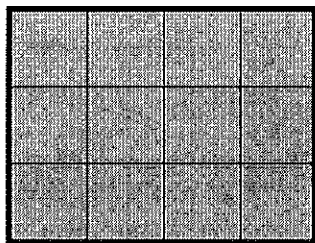

12 squares

I know that the amount of flat space a shape takes up is called its area.

I know these are called square units because the units used to measure area are squares. I also know that to measure area there shouldn't be any gaps or overlaps.

b. What is the area of the rectangle in square units? Explain how you found your answer.

The area of the rectangle is 12 square units. I know because I counted 12 squares inside the rectangle.

2. Each  is 1 square unit. Which rectangle has the largest area? How do you know?

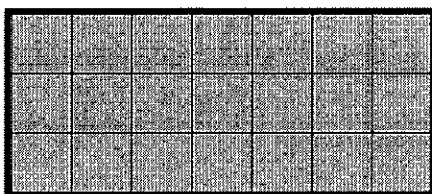

Rectangle A
21 square units

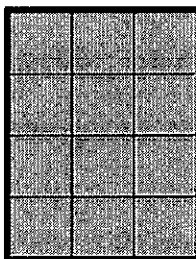

Rectangle B
12 square units

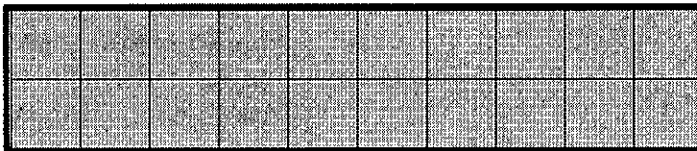

Rectangle C
20 square units

I can compare the areas of these rectangles because the same-sized square unit is used to cover each one.

Rectangle A has the largest area. I know because I counted the square units in each rectangle. Rectangle A needs the most squares to cover it with no gaps or overlaps.

G3-M4-Lesson 2

1. Matthew uses square inches to create these rectangles. Do they have the same area? Explain.



7 square inches

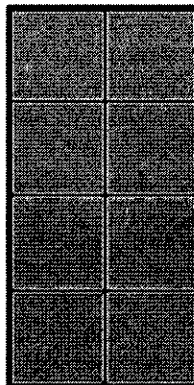

8 square inches

No, they do not have the same area. I counted the square inches in each rectangle and found that the rectangle on the right has a larger area by 1 square inch.

This is the new unit I learned today. Each side of a square inch measures 1 inch. The units in this drawing are just meant to represent square inches. I can write square inches as sq in for short.

2. Each  is a square unit. Count to find the area of the rectangle below. Then, draw a different rectangle that has the same area.

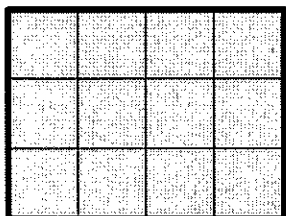

12 square units

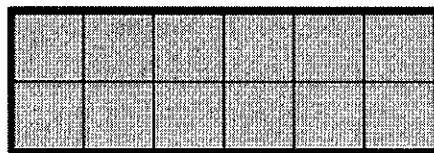

12 square units

I can rearrange the 12 square units into two equal rows to make a new rectangle. I know that rearranging the square units does not change the area because no new units are added, and none are taken away.

G3-M4-Lesson 3

1. Each  is 1 square unit. What is the area of each of the following rectangles?

a.



6 square units

I can find the area of each rectangle by counting the number of square units.

b.

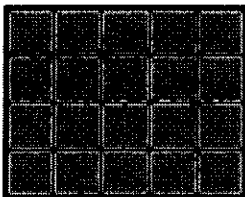

20 square units

2. How would the rectangles in Problem 1 be different if they were composed of square inches?

The number of squares in each rectangle would stay the same, but the side of each square would measure 1 inch. We would also label the area as square inches instead of square units.

3. How would the rectangles in Problem 1 be different if they were composed of square centimeters?

The number of squares in each rectangle would stay the same, but the side of each square would measure 1 centimeter. We would also label the area as square centimeters instead of square units.

I know 1 square inch covers a greater area than 1 square centimeter because 1 inch is longer than 1 centimeter.

G3-M4-Lesson 4

1. Use a ruler to measure the side lengths of the rectangle in centimeters. Mark each centimeter with a point, and draw lines from the points to show the square units. Then, count the squares you drew to find the total area.

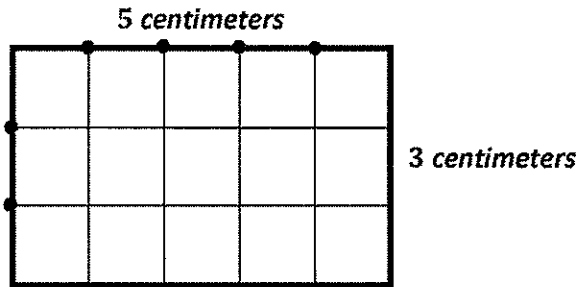

I know the side length of a rectangle is the same as the number of centimeter tiles that make it. I also know that opposite sides of rectangles are equal, so I only need to measure 2 sides.

Total area: 15 square centimeters

2. Each is 1 square centimeter. Sammy says that the side length of the rectangle below is 8 centimeters. Davis says the side length is 3 centimeters. Who is correct? Explain how you know.

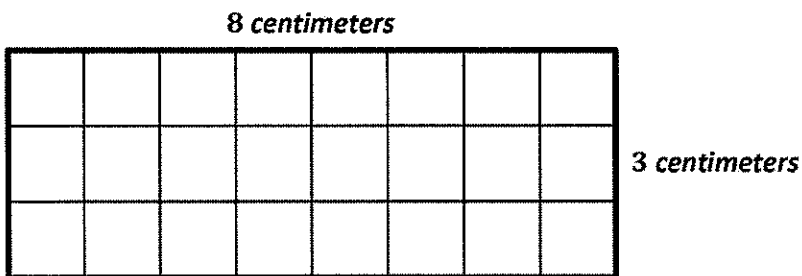

An efficient strategy to find the area is to think of this rectangle as 3 rows of 8 tiles, or 3 eights. Then we can skip-count by eights 3 times to find the total number of square centimeter tiles.

They are both correct because I counted the tiles across the top, and there are 8 tiles, which means that the side length is 8 cm. Then I counted the tiles along the side, and there are 3 tiles, which means that the side length is 3 cm.

3. Shana uses square inch tiles to find the side lengths of the rectangle below. Label each side length. Then, find the total area.

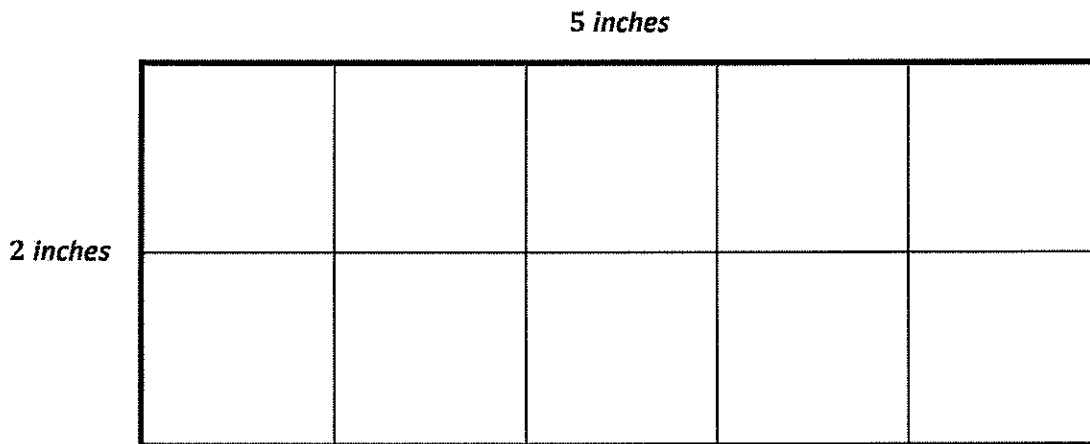

Total area: 10 square inches

I know the units are labeled differently for side lengths and area. I know the unit for side lengths is inches because the unit measures the length of the side in inches. For area, the unit is square inches because I count the number of square inch tiles that are used to make the rectangle.

4. How does knowing side lengths W and X help you find side lengths Y and Z on the rectangle below?

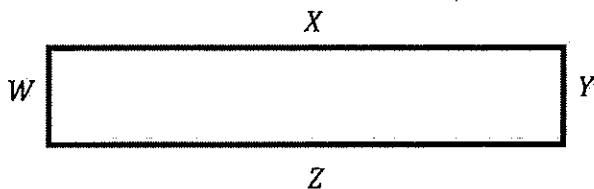

I know that opposite sides of a rectangle are equal. So, if I know side length X , I also know side length Z . If I know side length W , I also know side length Y .

G3-M4-Lesson 5

1. Use the centimeter side of a ruler to draw in the tiles. Then, find and label the unknown side length. Skip-count the tiles to check your work. Write a multiplication sentence for each tiled rectangle.

a. Area: 12 square centimeters

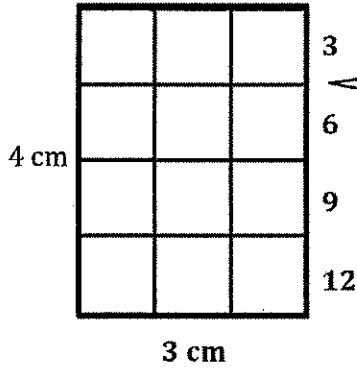

$$\underline{4} \times \underline{3} = \underline{12}$$

I can use my ruler to mark each centimeter. Then, I can connect the marks to draw the tiles. I'll count the square units and label the unknown side length 3 cm.

Next, I'll skip-count by 3 to check that the total number of tiles matches the given area of 12 square centimeters.

I can write 3 for the unknown factor because my tiled array shows 4 rows of 3 tiles.

b. Area: 12 square centimeters

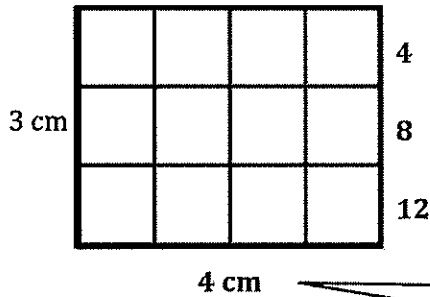

$$\underline{3} \times \underline{4} = \underline{12}$$

After I use my ruler to draw the tiles, I can count to find the unknown side length and label it.

I can write the number sentence $3 \times 4 = 12$ because there are 3 rows of 4 tiles, which is a total of 12 tiles.

The area of the rectangles in parts (a) and (b) is 12 square centimeters. That means both rectangles have the same area even though they look different.

2. Ella makes a rectangle with 24 square centimeter tiles. There are 4 equal rows of tiles.
- a. How many tiles are in each row? Use words, pictures, and numbers to support your answer.



I can draw columns of 4 tiles until I have a total of 24 tiles.

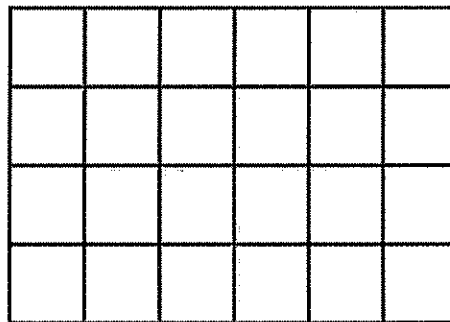

I had to draw 6 columns of 4 tiles to have a total of 24 tiles. That means there are 6 tiles in 1 row.

4 8 12 16 20 24

There are 6 tiles in each row. I drew columns of 4 tiles until I had a total of 24 tiles. Then I counted how many tiles are in 1 row. I could also find the answer by thinking about the problem as $4 \times \underline{\quad} = 24$ because I know that $4 \times 6 = 24$.

- b. Can Ella arrange all of her 24 square centimeter tiles into 3 equal rows? Use words, pictures, and numbers to support your answer.

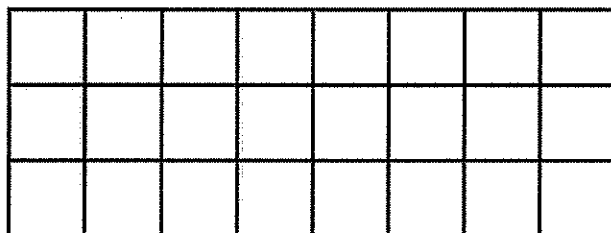

I drew columns of 3 tiles until I got to a total of 24 tiles. I had to draw 8 columns.

3 6 9 12 15 18 21 24

Yes, Ella can arrange all of her 24 tiles into 3 equal rows. I drew columns of 3 tiles until I had a total of 24 tiles. I can use my picture to see that there are 8 tiles in each row. I can also use multiplication to help me because I know that $3 \times 8 = 24$.

- c. Do the rectangles in parts (a) and (b) have the same total area? Explain how you know.

Yes, the rectangles in parts (a) and (b) have the same area because they are both made up of 24 square centimeter tiles. The rectangles look different because they have different side lengths, but they have the same area.

This is different than Problem 1 because the rectangles in Problem 1 had the same side lengths. They were just rotated.

G3-M4-Lesson 6

1. Each  represents 1 square centimeter. Draw to find the number of rows and columns in each array. Match it to its completed array. Then, fill in the blanks to make a true equation to find each array's area.

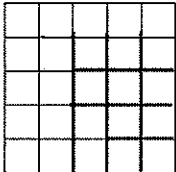
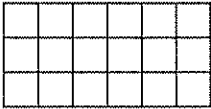
a.   $3 \text{ cm} \times 6 \text{ cm} = 18 \text{ sq cm}$

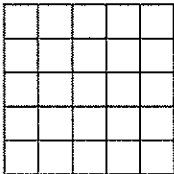
b.   $5 \text{ cm} \times 5 \text{ cm} = 25 \text{ sq cm}$

I can use the lines in the array and my ruler to help me complete the arrays.

I can count the number of rows and columns to fill in the blanks in the equations. Then I can multiply to find each array's area.

2. A painting covers the tile wall in Ava's kitchen, as shown below.

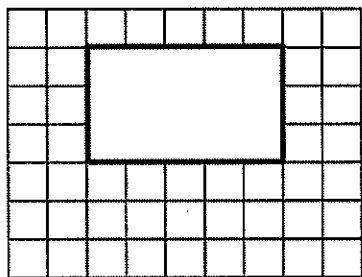

- a. Ava skip-counts by 9 to find the total number of square tiles on the wall. She says there are 63 square tiles. Is she correct? Explain your answer.

Yes, Ava is correct. Even though I can't see all of the tiles, I can use the first row and column to see that there are 7 rows of 9 tiles. I can multiply 7×9 , which equals 63.

- b. How many square tiles are under the painting?

I can use the tiles around the painting to help me figure out how many tiles are under the painting.

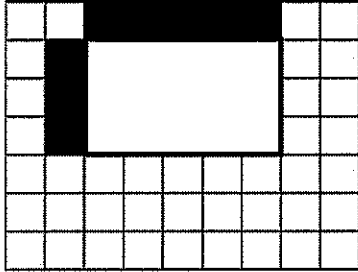

$$3 \times 5 = 15$$

There are 3 rows of square tiles and 5 columns of square tiles under the painting. I can multiply 3×5 to find the total number of tiles under the painting.

$$63 - 48 = 15$$

I know from part (a) that there are 63 total tiles. So, I could also solve by subtracting the number of tiles that I can see from the total.

There are 15 square tiles under the painting.

G3-M4-Lesson 7

1. Find the area of the rectangular array. Label the side lengths of the matching area model, and write a multiplication equation for the area model.

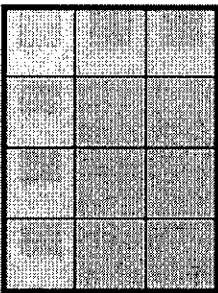
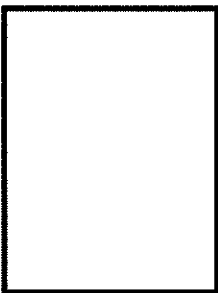
Rectangular Array	Area Model
 <p style="margin-left: 100px;"><u>12</u> square units</p>	 <p style="margin-left: 100px;"><u>4</u> units × <u>3</u> units = <u>12</u> square units</p> <p style="margin-left: 100px;"><u>3</u> units</p>

I can skip-count rows by 3 or columns by 4 to find the area of the rectangular array.

I can use the rectangular array to help me label the side lengths of the area model. There are 4 rows, so the width is 4 units. There are 3 columns, so the length is 3 units.

I can multiply 4×3 to find the area. The area model and the rectangular array have the same area of 12 square units.

2. Mason arranges square pattern blocks into a 3 by 6 array. Draw Mason's array on the the grid below. How many square units are in Mason's rectangular array?

a.

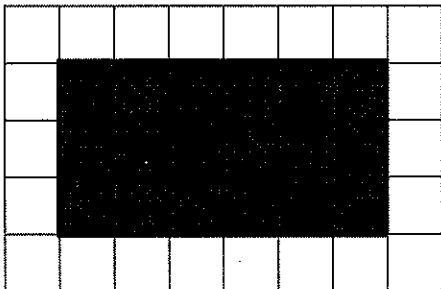

There are 18 square units in Mason's rectangular array.

I can draw a rectangular array with 3 rows and 6 columns. Then I can multiply 3×6 to find the total number of square units in the rectangular array.

- b. Label the side lengths of Mason's array from part (a) on the rectangle below. Then, write a multiplication sentence to represent the area of the rectangle.

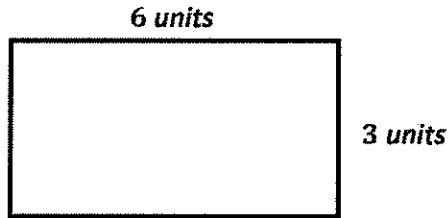

I can use the rectangular array in part (a) to help me label the side lengths of this area model. There are 3 rows and 6 columns in the rectangular array, so the side lengths are 3 units and 6 units.

$$3 \text{ units} \times 6 \text{ units} = 18 \text{ square units}$$

I can multiply the side lengths to find the area.

3. Luke draws a rectangle that is 4 square feet. Savannah draws a rectangle that is 4 square inches. Whose rectangle is larger in area? How do you know?

Luke's rectangle is larger in area because they both used the same number of units, but the size of the units is different. Luke used square feet, which are larger than square inches. Since the units that Luke used are larger than the units that Savannah used and they both used the same number of units, Luke's rectangle is larger in area.

I can think about the lesson today to help me answer this question. My partner and I made rectangles using square inch and square centimeter tiles. We both used the same number of tiles to make our rectangles, but we noticed that the rectangle made of square inches was larger in area than the rectangle made of square centimeters. The larger unit, square inches, made a rectangle with a larger area.

G3-M4-Lesson 8

1. Write a multiplication equation to find the area of the rectangle.

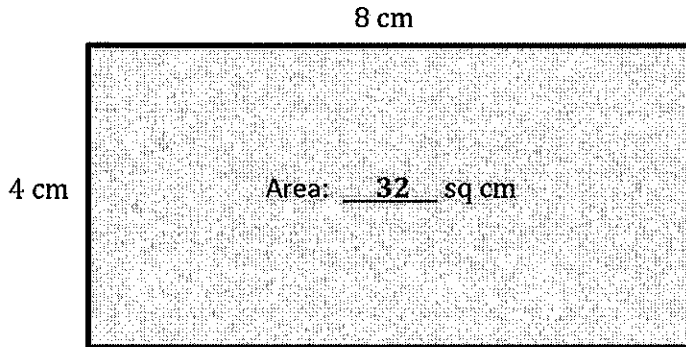

I know that I can multiply the side lengths, 4 and 8, to find the area.

$$\underline{4} \times \underline{8} = \underline{32}$$

2. Write a multiplication equation and a division equation to find the unknown side length for the rectangle.

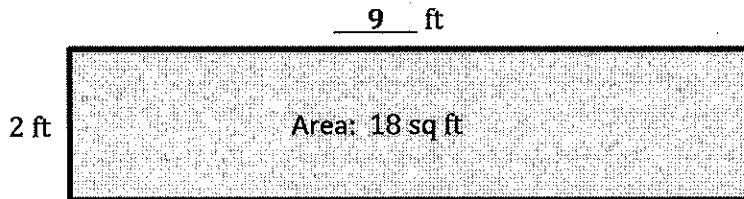

To solve, I can think of this as multiplication with an unknown factor, $2 \times \underline{\quad} = 18$. Or, I can divide the area by the known side length, $18 \div 2 = \underline{\quad}$. Either way, the answer is 9.

$$\underline{2} \times \underline{9} = \underline{18}$$

$$\underline{18} \div \underline{2} = \underline{9}$$

3. On the grid below, draw a rectangle that has an area of 24 square units. Label the side lengths.

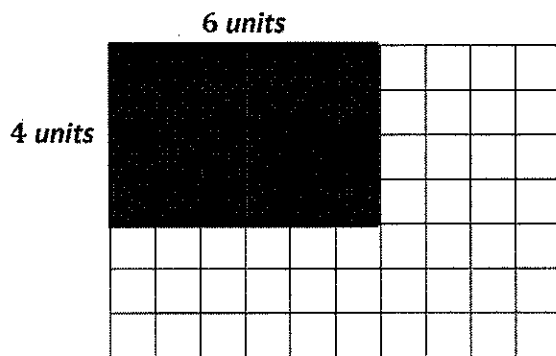

To draw a rectangle with an area of 24 square units, I can think about factors of 24. I know $4 \times 6 = 24$, so my side lengths can be 4 and 6.

4. Keith draws a rectangle that has side lengths of 6 inches and 3 inches. What is the area of the rectangle? Explain how you found your answer.

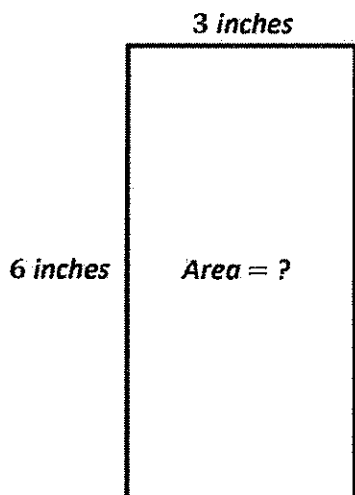

I can draw and label an area model to help me solve.

I can multiply the side lengths to find the area.

$$6 \times 3 = 18$$

The area of the rectangle is 18 square inches. I multiplied the side lengths, 6 inches and 3 inches, to find the answer.

5. Isabelle draws a rectangle with a side length of 5 centimeters and an area of 30 square centimeters. What is the other side length? How do you know?

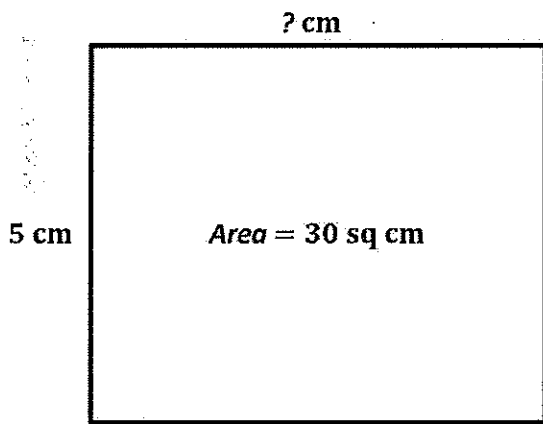

This is different than Problem 4 because the unknown is one of the side lengths.

When I know the area and one side length, I can divide to find the other side length. Or, I can think of this as an unknown factor problem: $5 \times \underline{\quad} = 30$.

$$30 \div 5 = 6$$

The other side length is 6 centimeters. I divided the area, 30 square centimeters, by the known side length, 5 centimeters, and $30 \div 5 = 6$.

G3-M4-Lesson 9

1. Use the grid to answer the questions below.

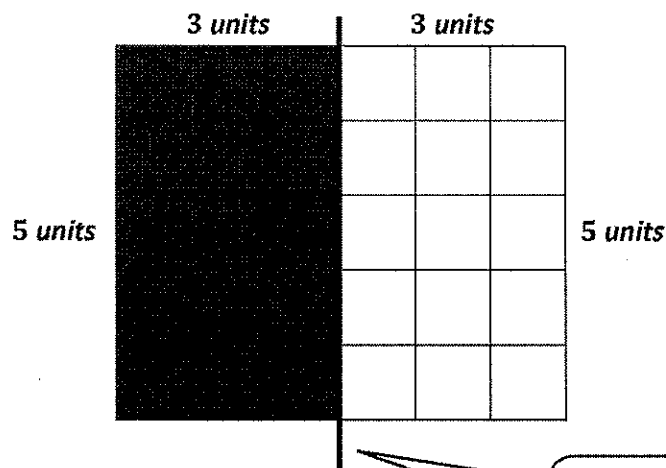

I can draw a line between the 3rd and 4th columns to make 2 equal rectangles.

- a. Draw a line to divide the grid into 2 equal rectangles. Shade in 1 of the rectangles that you created.

- b. Label the side lengths of each rectangle.

I can count the units on each side to help me label the side lengths of each rectangle.

- c. Write an equation to show the total area of the 2 rectangles.

$$\begin{aligned} \text{Area} &= (5 \times 3) + (5 \times 3) \\ &= 15 + 15 \\ &= 30 \end{aligned}$$

The total area is 30 square units.

I can find the area of each smaller rectangle by multiplying 5×3 . Then, I can add the areas of the 2 equal rectangles to find the total area.

2. Phoebe cuts out the 2 equal rectangles from Problem 1(a) and puts the two shorter sides together.
- a. Draw Phoebe's new rectangle, and label the side lengths below.

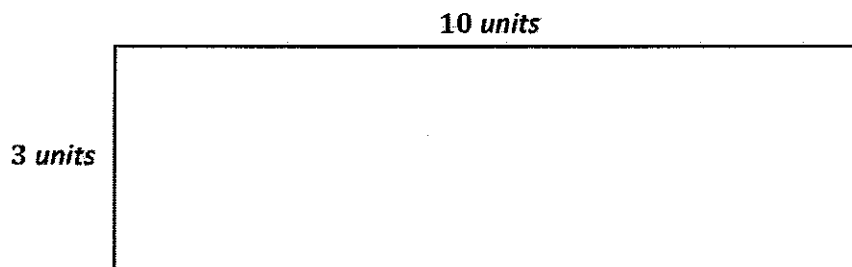

I can label the side lengths using what I know about the 2 equal rectangles in Problem 1. The length of this rectangle is 10 units because $5 \text{ units} + 5 \text{ units} = 10 \text{ units}$.

- b. Find the total area of the new, longer rectangle.

$$\begin{aligned} \text{Area} &= 3 \times 10 \\ &= 30 \end{aligned}$$

I can find the area by multiplying the side lengths.

- c. *The total area is 30 square units.*

- c. Is the area of the new, longer rectangle equal to the total area in Problem 1(c)? Explain why or why not.

Yes, the area of the new, longer rectangle is equal to the total area in Problem 1(c). Phoebe just rearranged the 2 smaller, equal rectangles, so the total area didn't change.

I know that the total area doesn't change just because the 2 equal rectangles were moved around to form a new, longer rectangle. No units were taken away and none were added, so the area stays the same.

G3-M4-Lesson 10

1. Label the side lengths of the shaded and unshaded rectangles. Then, find the total area of the large rectangle by adding the areas of the 2 smaller rectangles.

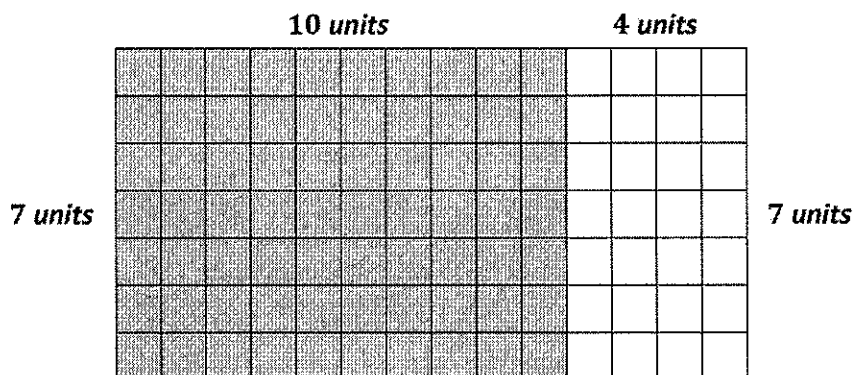

$$\begin{aligned}
 7 \times 14 &= 7 \times (\underline{10} + \underline{4}) \\
 &= (7 \times \underline{10}) + (7 \times \underline{4}) \\
 &= \underline{70} + \underline{28} \\
 &= \underline{98}
 \end{aligned}$$

Area: 98 square units

I can count the units on each side to help me label the side lengths of each rectangle.

2. Vickie imagines 1 more row of seven to find the total area of a 9×7 rectangle. Explain how this could help her solve 9×7 .

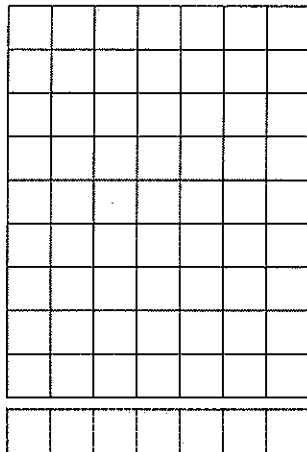

This can help her solve 9×7 because now she can think of it as 10×7 minus 1 seven. 10×7 might be easier for Vickie to solve than 9×7 .

$$10 \times 7 = 70$$

$$70 - 7 = 63$$

This reminds me of the $9 = 10 - 1$ strategy that I can use to multiply by 9.

3. Break the 16×6 rectangle into 2 rectangles by shading one smaller rectangle within it. Then, find the total area by finding the sum of the areas of the 2 smaller rectangles. Explain your thinking.

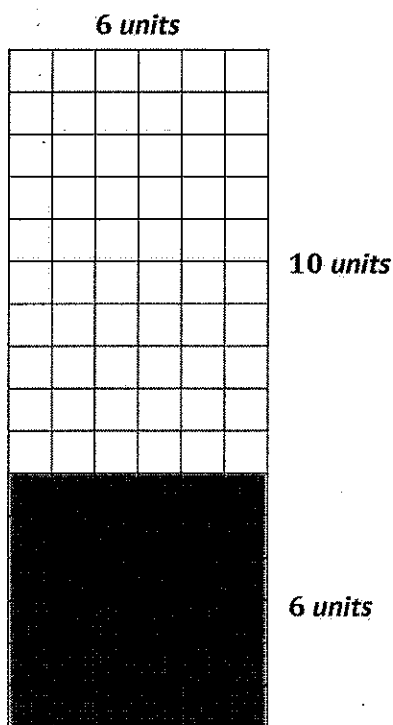

$$\text{Area} = (10 \times 6) + (6 \times 6)$$

$$= 60 + 36$$

$$= 96$$

The total area is 96 square units.

I broke apart the 16×6 rectangle into 2 smaller rectangles: 10×6 and 6×6 . I chose to break it apart like this because those are easy facts for me. I multiplied the side lengths to find the area of each smaller rectangle and added those areas to find the total area.

I can break apart the rectangle any way I want to, but I like to look for facts that are easy for me to solve. Multiplying by 10 is easy for me. I also could have broken it apart into 8×6 and 8×6 . Then I would really only have to solve one fact.

G3-M4-Lesson 11

1. The rectangles below have the same area. Move the parentheses to find the unknown side lengths. Then, solve.

a.

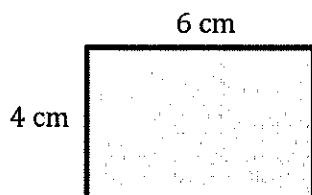

$$\text{Area: } 4 \times \underline{6} = \underline{24}$$

$$\text{Area: } \underline{24} \text{ sq cm}$$

I can multiply the side lengths to find the area.

b.

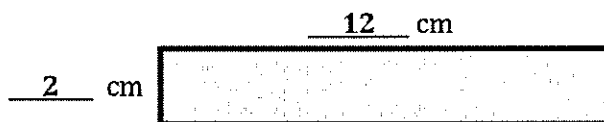

$$\begin{aligned} \text{Area: } 4 \times 6 &= (2 \times 2) \times 6 \\ &= 2 \times (2 \times 6) \\ &= \underline{2} \times \underline{12} \\ &= \underline{24} \end{aligned}$$

$$\text{Area: } \underline{24} \text{ sq cm}$$

I can move the parentheses to be around 2×6 . After I multiply 2×6 , I have new side lengths of 2 cm and 12 cm. I can label the side lengths on the rectangle. The area didn't change; it's still 24 sq cm.

2. Does Problem 1 show all the possible whole number side lengths for a rectangle with an area of 24 square centimeters? How do you know?

No, Problem 1 doesn't show all possible whole number side lengths. I check by trying to multiply each number 1 through 10 by another number to equal 24. If I can find numbers that make 24 when I multiply them, then I know those are possible side lengths.

I know $1 \times 24 = 24$. So 1 cm and 24 cm are possible side lengths. I already have a multiplication fact for 2, 2×12 . I know $3 \times 8 = 24$, which means $8 \times 3 = 24$. I already have a multiplication fact for 4, 4×6 . That also means that I have a fact for 6, $6 \times 4 = 24$. I know there's not a whole number that can be multiplied by 5, 7, 9, or 10 that equals 24. So besides the side lengths from Problem 1, other ones could be 1 cm and 24 cm or 8 cm and 3 cm.

I know that I can't have side lengths that are both two-digit numbers because when I multiply 2 two-digit numbers, the product is much larger than 24.

3.

- a. Find the area of the rectangle below.

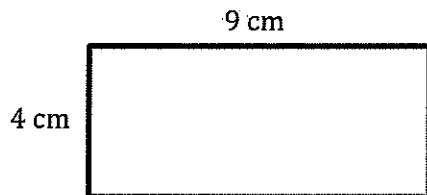

$$\begin{aligned} \text{Area} &= 4 \times 9 \\ &= 36 \end{aligned}$$

The area of the rectangle is 36 square centimeters.

- b. Marcus says a 2 cm by 18 cm rectangle has the same area as the rectangle in part (a). Place parentheses in the equation to find the related fact and solve. Is Marcus correct? Why or why not?

$$\begin{aligned} 2 \times 18 &= 2 \times (2 \times 9) \\ &= (2 \times 2) \times 9 \\ &= \underline{4} \times \underline{9} \\ &= \underline{36} \end{aligned}$$

Yes, Marcus is correct because I can rewrite 18 as 2×9 . Then I can move the parentheses so they are around 2×2 . After I multiply 2×2 , I have 4 cm and 9 cm as side lengths, just like in part (a).

$$2 \times 18 = 4 \times 9 = 36$$

Area: 36 sq cm

Even though the rectangles in parts (a) and (b) have different side lengths, the areas are the same. Rewriting 18 as 2×9 and moving the parentheses helps me to see that $2 \times 18 = 4 \times 9$.

- c. Use the expression
- 4×9
- to find different side lengths for a rectangle that has the same area as the rectangle in part (a). Show your equations using parentheses. Then, estimate to draw the rectangle and label the side lengths.

$$\begin{aligned} 4 \times 9 &= 4 \times (3 \times 3) \\ &= (4 \times 3) \times 3 \\ &= 12 \times 3 \\ &= 36 \end{aligned}$$

Area: 36 sq cm

I can rewrite 9 as 3×3 . Then I can move the parentheses and multiply to find the new side lengths, 12 cm and 3 cm. I can estimate to draw the new rectangle. If I need to, I can use repeated addition, $12 + 12 + 12$, to double check that $12 \times 3 = 36$.

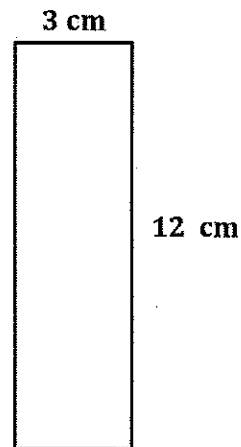

G3-M4-Lesson 12

1. Molly draws a square with sides that are 8 inches long. What is the area of the square?

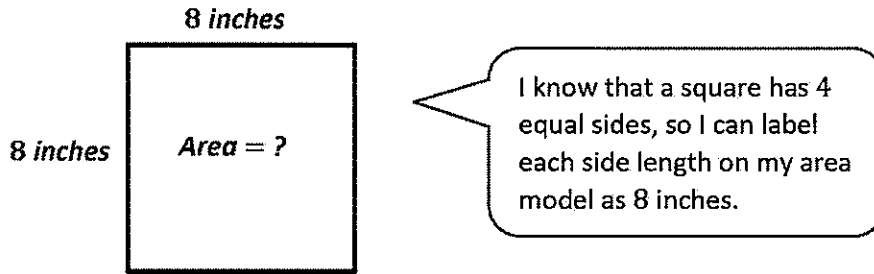

$$8 \times 8 = 64$$

I can multiply the side lengths to find the area.

The area of the square is 64 square inches.

2. Each  is 1 square unit. Nathan uses the same square units to draw a 2×8 rectangle and says that it has the same area as the rectangle below. Is he correct? Explain why or why not.

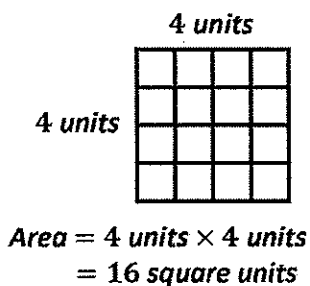

I can count the units to label the side lengths and then multiply to find the area. Or, I can count all of the units to find the area.

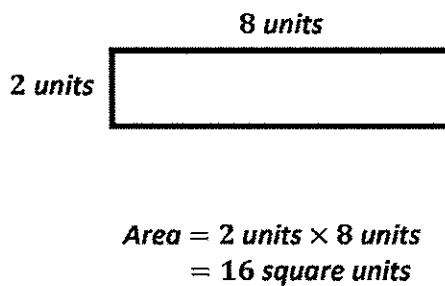

I can draw an area model with side lengths of 2 units and 8 units to represent Nathan's rectangle. I can multiply the side lengths to find the area.

Yes, Nathan is correct. Both rectangles have the same area, 16 square units. The rectangles have different side lengths, but when you multiply the side lengths, you get the same area.

$$4 \times 4 = 2 \times 8 = 16$$

3. A rectangular notepad has a total area of 24 square inches. Draw and label two possible notepads with different side lengths, each having an area of 24 square inches.

1×24
 2×12
 3×8
 4×6

I can list multiplication facts that equal 24 to help me think of possible side lengths.

I can choose 2 facts to use as side lengths for my rectangles. I know the unit is inches because the area is in square inches.

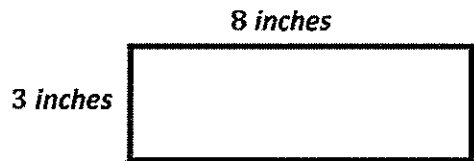

$Area = 3 \text{ inches} \times 8 \text{ inches}$
 $= 24 \text{ square inches}$

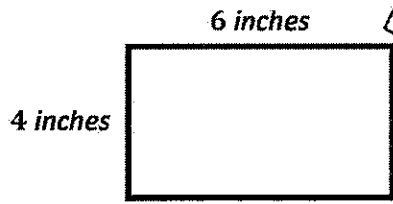

$Area = 4 \text{ inches} \times 6 \text{ inches}$
 $= 24 \text{ square inches}$

I can check my work by multiplying the side lengths to be sure the area of each rectangle is 24 square inches.

4. Sophia makes the pattern below. Find and explain her pattern. Then, draw the fifth figure in her pattern.

I can see that the first figure has 1 row of three, the second figure has 2 rows of three, and the third figure has 3 rows of three. Sophia adds 1 row of three to each new figure.

I'll follow the pattern by drawing 4 rows of three for the fourth figure and 5 rows of three for the fifth figure.

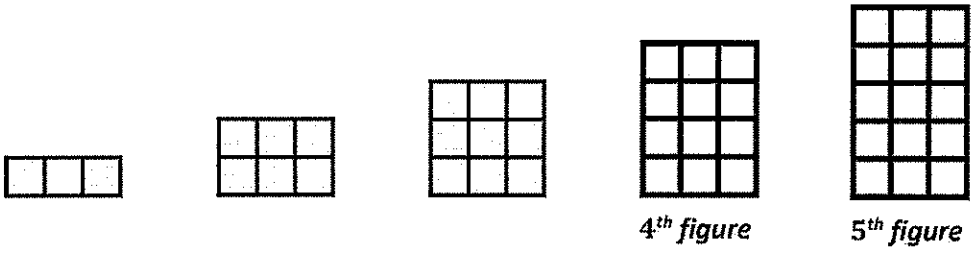

Sophia adds 1 row of three to each figure. The fifth figure has 5 rows of three.

G3-M4-Lesson 13

1. The shaded figure below is made up of 2 rectangles. Find the total area of the shaded figure.

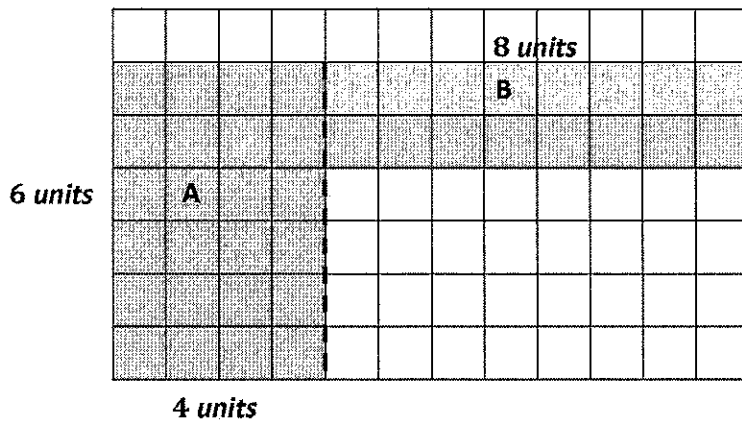

2 units

I can count the square units and label the side lengths of each rectangle inside the figure.

$$6 \times 4 = 24$$

$$2 \times 8 = 16$$

I can multiply the side lengths to find the area of each rectangle inside the figure.

Area of A: 24 sq units

Area of B: 16 sq units

I can add the areas of the rectangles to find the total area of the figure.

$$\text{Area of A} + \text{Area of B} = \underline{24} \text{ sq units} + \underline{16} \text{ sq units} = \underline{40} \text{ sq units}$$

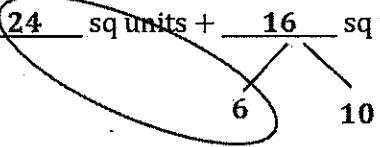

$$24 + 6 = 30$$

$$30 + 10 = 40$$

I can use a number bond to help me make a ten to add. I can decompose 16 into 6 and 10. $24 + 6 = 30$ and $30 + 10 = 40$. The area of the figure is 40 square units.

2. The figure shows a small rectangle cut out of a big rectangle. Find the area of the shaded figure.

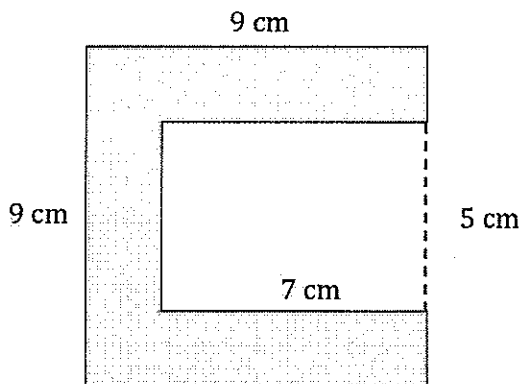

$$9 \times 9 = 81$$

$$5 \times 7 = 35$$

I can multiply the side lengths to find the areas of the large rectangle and the unshaded rectangle.

Area of the shaded figure: $81 - 35 = 46$

Area of the shaded figure: 46 square centimeters

I can subtract the area of the unshaded rectangle from the area of the large rectangle. That helps me find just the area of the shaded figure.

3. The figure shows a small rectangle cut out of a big rectangle.

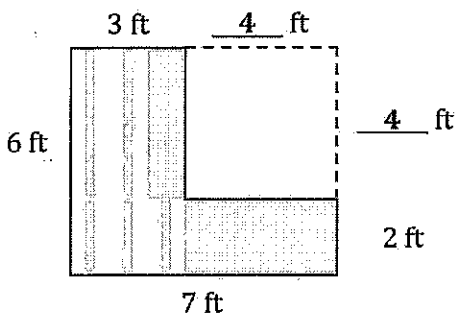

I can label this as 4 ft because the opposite side of the rectangle is 6 ft. Since opposite sides of rectangles are equal, I can subtract the known part of this side length, 2 ft, from the opposite side length, 6 ft. $6 \text{ ft} - 2 \text{ ft} = 4 \text{ ft}$. I can use a similar strategy to find the other unknown measurement: $7 \text{ ft} - 3 \text{ ft} = 4 \text{ ft}$.

- Label the unknown measurements.
- Area of the big rectangle: $6 \text{ ft} \times 7 \text{ ft} = 42 \text{ sq ft}$
- Area of the small rectangle: $4 \text{ ft} \times 4 \text{ ft} = 16 \text{ sq ft}$
- Find the area of just the shaded part.

$$42 \text{ sq ft} - 16 \text{ sq ft} = 26 \text{ sq ft}$$

The area of the shaded figure is 26 sq ft

I can subtract the area of the small rectangle from the area of the big rectangle to find the area of just the shaded part.

G3-M4-Lesson 14

1. Find the area of the following figure, which is made up of rectangles.

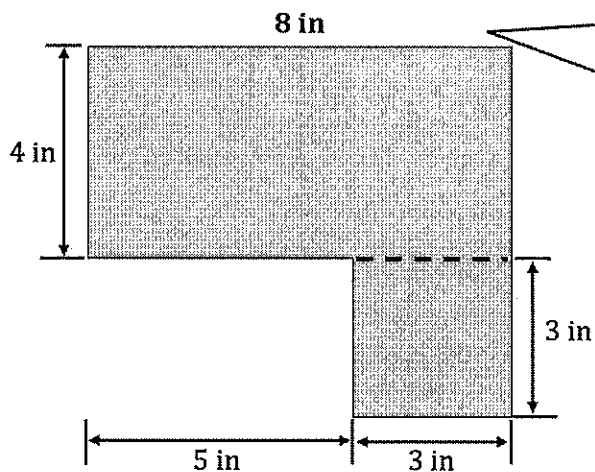

I can label this unknown side length as 8 inches because the opposite side is 5 inches and 3 inches, which makes a total of 8 inches. Opposite sides of a rectangle are equal.

$$4 \times 8 = 32$$

$$3 \times 3 = 9$$

$$32 + 9 = ?$$

$$31 \begin{array}{r} 1 \\ \times 9 \\ \hline \end{array}$$

$$1 + 9 = 10$$

$$31 + 10 = 41$$

I can find the area of the figure by finding the areas of the two rectangles and then adding. I can use a number bond to make adding easier.

The area of the figure is 41 square inches.

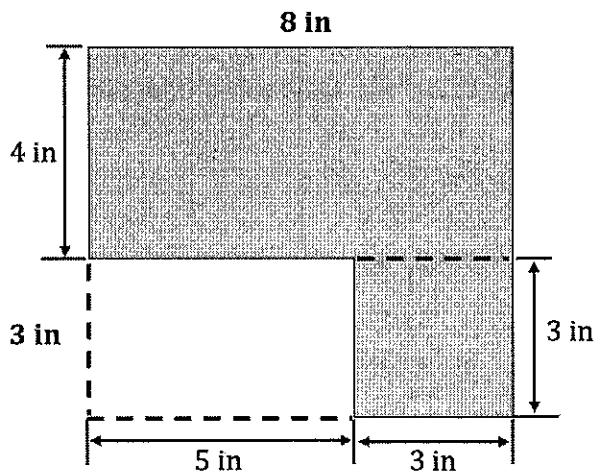

Or, I can find the area of the figure by drawing lines to complete the large rectangle. Then I can find the areas of the large rectangle and the unshaded part. I can subtract the area of the unshaded part from the area of the large rectangle. Either way I solve, the area of the figure is 41 square inches.

$$8 \times 7 = 56$$

$$3 \times 5 = 15$$

$$56 - 15 = 41$$

I can label this unknown side length as 3 inches because the opposite side is 3 inches.

2. The figure below shows a small rectangle cut out of a big rectangle. Find the area of the shaded region.

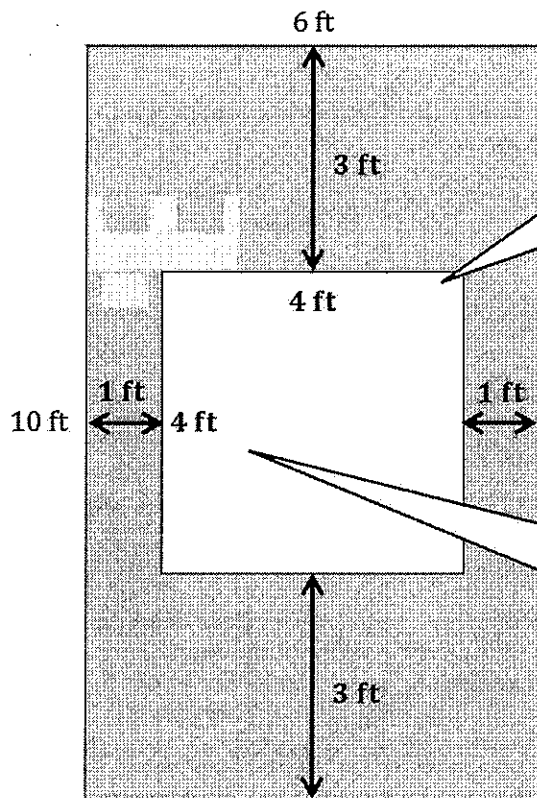

I can label this side length as 4 feet. The length of the large rectangle is 6 feet. The shaded regions on either side of the small rectangle are labeled as 1 foot. $6 - (1 + 1) = 4$

I can label this side length as 4 feet. The width of the large rectangle is 10 feet. The shaded regions above and below the small rectangle are labeled as 3 feet. $10 - (3 + 3) = 4$

$$10 \times 6 = 60$$

$$4 \times 4 = 16$$

$$60 - 16 = ?$$

$$20 - 16 = 4$$

$$40 + 4 = 44$$

The area of the shaded region is 44 square feet.

I can find the areas of the large rectangle and the unshaded rectangle. Then I can subtract the area of the unshaded rectangle from the area of the large rectangle to find the area of the shaded region.

I can use a number bond to make the subtraction easier.

G3-M4-Lesson 15

Use a ruler to measure the side lengths of each numbered room in the floor plan in centimeters. Then, find each area. Use the measurements below to match and label the rooms.

Kitchen/Living Room: 78 square centimeters

Bedroom: 48 square centimeters

Bathroom: 24 square centimeters

Hallway: 6 square centimeters

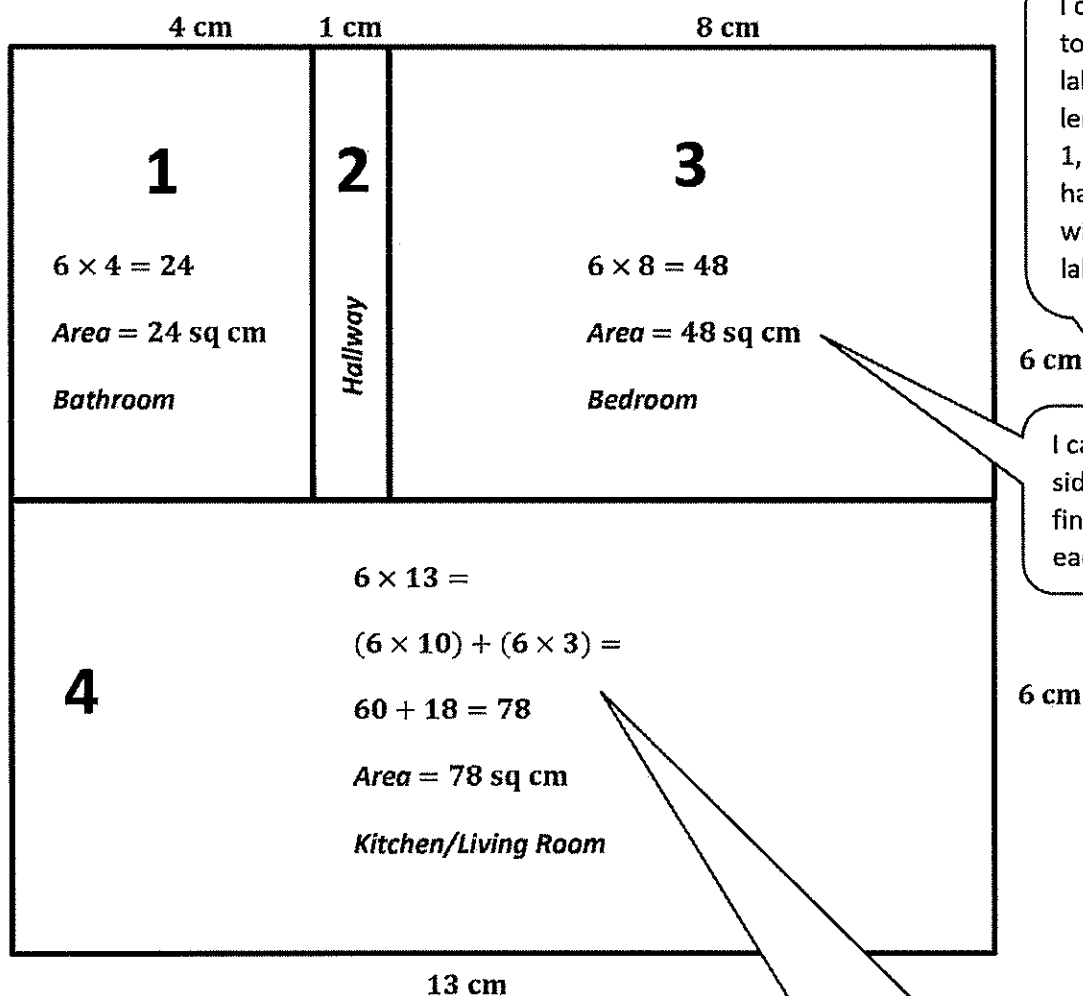

I can use my ruler to measure and label the side lengths. Rooms 1, 2, and 3 all have the same width, so I only labeled it once.

I can multiply the side lengths to find the area of each room.

I can use the break apart and distribute strategy to find the area of Room 4.

Area of Room 2:

$$6 \times 1 = 6$$

$$\text{Area} = 6 \text{ sq cm}$$

G3-M4-Lesson 16

Mrs. Harris designs her dream classroom on grid paper. The chart shows how much space she gives for each rectangular area. Use the information in the chart to draw and label a possible design for Mrs. Harris's classroom.

Reading area	48 square units	6×8
Carpet area	72 square units	9×8
Student desk area	90 square units	10×9
Science area	56 square units	7×8
Math area	64 square units	8×8

I can think of multiplication facts that equal each area. Then I can use the multiplication facts as the side lengths of each rectangular area. I can use the grid to help me draw each rectangular area.

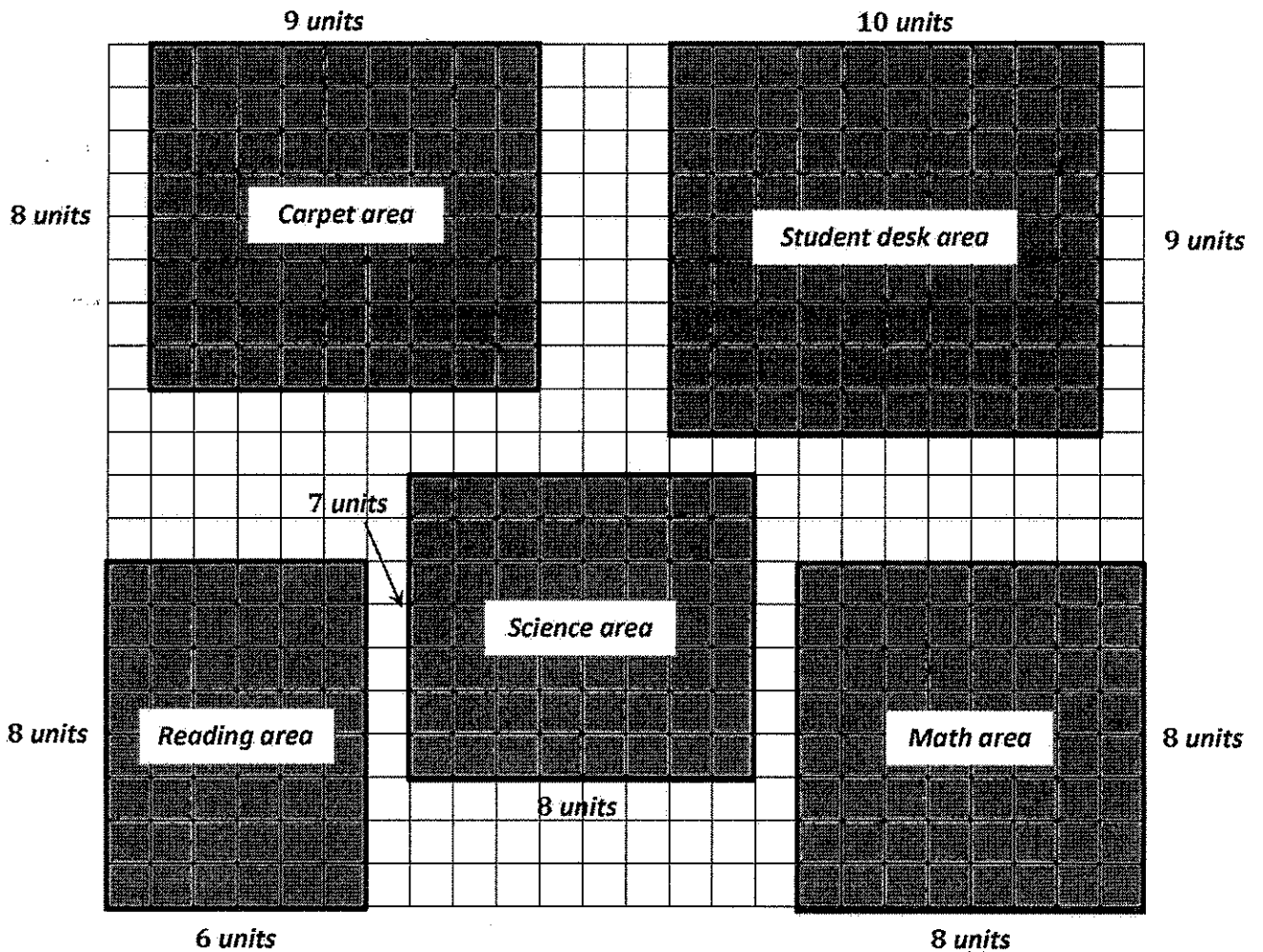

Handwritten text, possibly bleed-through from the reverse side of the page.