

Work, Power, and Machines

KEY TERM

work
power
mechanical advantage

OBJECTIVES

- ▶ **Define** *work* and *power*.
- ▶ **Calculate** the work done on an object and the rate at which work is done.
- ▶ **Use** the concept of mechanical advantage to explain how machines make doing work easier.
- ▶ **Calculate** the mechanical advantage of various machines.

If you needed to change a flat tire, you would probably use a car jack to lift the car. Machines—from complex ones such as a car to relatively simple ones such as a car jack, a hammer, or a ramp—help people get things done every day.

work the transfer of energy to a body by the application of a force that causes the body to move in the direction of the force

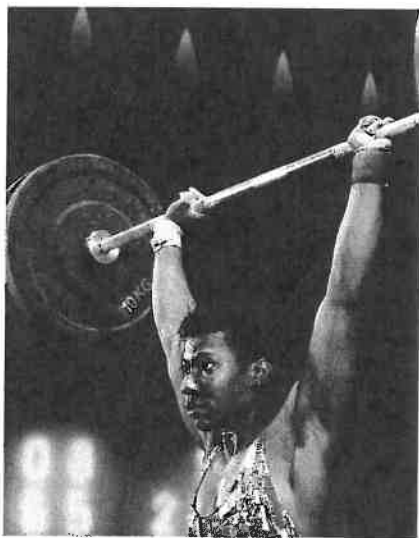

Figure 1

As this weightlifter holds the barbell over her head, is she doing any work on the barbell?

What Is Work?

Imagine trying to lift the front of a car without using a jack. You could exert a lot of force without moving the car at all. Exerting all that force might seem like hard work. In science, however, the word **work** has a very specific meaning.

Work is done only when force causes a change in the position or the motion of an object in the direction of the applied force. Work is calculated by multiplying the force by the distance over which the force is applied. We will always assume that the force used to calculate work is acting along the line of motion of the object.

Work Equation

$$\text{work} = \text{force} \times \text{distance}$$

$$W = F \times d$$

In the case of trying to lift the car, you might apply a large force, but if the distance that the car moves is equal to zero, the work done on the car is also equal to zero.

However, once the car moves even a small amount, you have done some work on it. You could calculate how much by multiplying the force you have applied by the distance the car moves.

The weightlifter in **Figure 1** is applying a force to the barbell as she holds it overhead, but the barbell is not moving. Is she doing any work on the barbell?

Work is measured in joules

Because work is calculated as force times distance, it is measured in units of newtons times meters, $\text{N}\cdot\text{m}$. These units are also called *joules* (J). In terms of SI base units, a joule is equivalent to $1 \text{ kg}\cdot\text{m}^2/\text{s}^2$.

$$1 \text{ N}\cdot\text{m} = 1 \text{ J} = 1 \text{ kg}\cdot\text{m}^2/\text{s}^2$$

Because these units are all equal, you can choose whichever unit is easiest for solving a particular problem. Substituting equivalent units will often help you cancel out other units in a problem.

You do about 1 J of work when you slowly lift an apple, which weighs about 1 N, from your arm's length down at your side to the top of your head, a distance of about 1 m.

Math Skills

Work Imagine a father playing with his daughter by lifting her repeatedly in the air. How much work does he do with each lift, assuming he lifts her 2.0 m and exerts an average force of 190 N?

1 List the given and unknown values.

Given: force, $F = 190 \text{ N}$
distance, $d = 2.0 \text{ m}$

Unknown: work, $W = ? \text{ J}$

2 Write the equation for work.

$$\text{work} = \text{force} \times \text{distance} \quad W = F \times d$$

3 Insert the known values into the equation, and solve.

$$W = 190 \text{ N} \times 2.0 \text{ m} = 380 \text{ N}\cdot\text{m} = 380 \text{ J}$$

Practice

Work

1. A crane uses an average force of 5200 N to lift a girder 25 m. How much work does the crane do on the girder?
2. An apple weighing 1 N falls through a distance of 1 m. How much work is done on the apple by the force of gravity?
3. The brakes on a bicycle apply 125 N of frictional force to the wheels as the bicycle travels 14.0 m. How much work have the brakes done on the bicycle?
4. While rowing in a race, John uses his arms to exert a force of 165 N per stroke while pulling the oar 0.800 m. How much work does he do in 30 strokes?
5. A mechanic uses a hydraulic lift to raise a 1200 kg car 0.5 m off the ground. How much work does the lift do on the car?



Disc Two, Module 10: Work

Use the Interactive Tutor to learn more about this topic.

Practice HINT

- In order to use the work equation, you must use units of newtons for force and units of meters for distance. Practice Problem 5 gives a mass in kilograms instead of a weight in newtons. To convert from mass to force (weight), use the definition of weight from Section 3:

$$w = mg$$

where m is the mass in kilograms and $g = 9.8 \text{ m/s}^2$. Then plug the value for weight into the work equation as the force.

■ **power** a quantity that measures the rate at which work is done or energy is transformed

Power

Running up a flight of stairs doesn't require more work than walking up slowly does, but it is more exhausting. The amount of time it takes to do work is an important factor when considering work and machines. The quantity that measures work in relation to time is **power**. Power is the rate at which work is done, that is, how much work is done in a given amount of time.

Power Equation

$$\text{power} = \frac{\text{work}}{\text{time}} \quad P = \frac{W}{t}$$

Running takes less time than walking does. How does reducing the time in this equation affect the power if the amount of work stays the same?

Power is measured in watts

Power is measured in SI units called *watts* (W). A watt is the amount of power required to do 1 J of work in 1 s, about as much power as you need to lift an apple over your head in 1 s. Do not confuse the abbreviation for watts, W, with the symbol for work, *W*. You can tell which one is meant by the context in which it appears and by whether it is in italics.

Quick Lab

What is your power output when you climb the stairs?

Materials ✓ flight of stairs ✓ stopwatch ✓ meterstick

1. Determine your weight in newtons. If your school has a scale that reads in kilograms, multiply your mass in kilograms by 9.8 m/s^2 to determine your weight in newtons. If your school has a scale that weighs in pounds, multiply your weight by a factor of 4.45 N/lb.
2. Divide into pairs. Have your partner use the stopwatch to time how long it takes you to walk quickly up the stairs. Record the time. Then switch roles and repeat.
3. Measure the height of one step in meters. Multiply the number of steps by the height of one step to get the total height of the stairway.
4. Multiply your weight in newtons by the height of the stairs in meters to get the work you did in

joules. Recall the work equation:
 $\text{work} = \text{force} \times \text{distance}$, or
 $W = F \times d$.

5. To get your power in watts, divide the work done in joules by the time in seconds that it took you to climb the stairs.

Analysis

1. How would your power output change if you walked up the stairs faster?
2. What would your power output be if you climbed the same stairs in the same amount of time while carrying a stack of books weighing 20 N?
3. Why did you use your weight as the force in the work equation?



Math Skills

Power It takes 100 kJ of work to lift an elevator 18 m. If this is done in 20 s, what is the average power of the elevator during the process?

1 List the given and unknown values.

Given: work, $W = 100 \text{ kJ} = 1 \times 10^5 \text{ J}$

time, $t = 20 \text{ s}$

The distance of 18 m will not be needed to calculate power.

Unknown: power, $P = ? \text{ W}$

2 Write the equation for power.

$$\text{power} = \frac{\text{work}}{\text{time}} \quad P = \frac{W}{t}$$

3 Insert the known values into the equation, and solve.

$$P = \frac{1 \times 10^5 \text{ J}}{20 \text{ s}} = 5 \times 10^3 \text{ J/s}$$

$$P = 5 \times 10^3 \text{ W}$$

$$P = 5 \text{ kW}$$

Practice

Power

1. While rowing across the lake during a race, John does 3960 J of work on the oars in 60.0 s. What is his power output in watts?
2. Every second, a certain coal-fired power plant produces enough electricity to do $9 \times 10^8 \text{ J}$ (900 MJ) of work. What is the power output of this power plant in units of watts (or in units of megawatts)?
3. Using a jack, a mechanic does 5350 J of work to lift a car 0.500 m in 50.0 s. What is the mechanic's power output?
4. Suppose you are moving a 300 N box of books. Calculate your power output in the following situations:
 - a. You exert a force of 60.0 N to push the box across the floor 12.0 m in 20.0 s.
 - b. You lift the box 1 m onto a truck in 3 s.
5. Anna walks up the stairs on her way to class. She weighs 565 N and the stairs go up 3.25 m vertically.
 - a. Calculate her power output if she climbs the stairs in 12.6 s.
 - b. What is her power output if she climbs the stairs in 10.5 s?

Did You Know?

Another common unit of power is horsepower (hp). This originally referred to the average power output of a draft horse. One horsepower equals 746 W. With that much power, a horse could raise a load of 746 apples, weighing 1 N each, by 1 m every second.

Practice HINT

- In order to calculate power in Practice Problems 4 and 5, you must first use the work equation to calculate the work done in each case.



Figure 2

A jack makes it easier to lift a car by multiplying the input force and spreading the work out over a large distance.

Machines and Mechanical Advantage

Which is easier, lifting a car yourself or using a jack as shown in **Figure 2**? Which requires more work? Using a jack is obviously easier. But you may be surprised to learn that using a jack requires the same amount of work. The jack makes the work easier by allowing you to apply less force at any given moment.

Machines multiply and redirect forces

Machines help us do work by redistributing the work that we put into them. Machines can change the direction of an input force. Machines can also increase or decrease force by changing the distance over which the force is applied. This process is often called multiplying the force.

Different forces can do the same amount of work

Compare the amount of work required to lift a box straight onto the bed of a truck, as shown in **Figure 3A**, with the amount of work required to push the same box up a ramp, as shown in **Figure 3B**. When the mover lifts straight up, he must apply 225 N of force for a short distance. Using the ramp, he can apply a smaller force over a longer distance. But the work done is about the same in both cases.

Both a car jack and a loading ramp make doing work easier by increasing the distance over which force is applied. As a result, the force required at any point is reduced. Therefore, a machine allows the same amount of work to be done by either decreasing the distance while increasing the force or by decreasing the force while increasing the distance.

Figure 3

A When lifting a box straight up, a mover applies a large force over a short distance.

B Using a ramp to lift the box, the mover applies a smaller force over a longer distance.

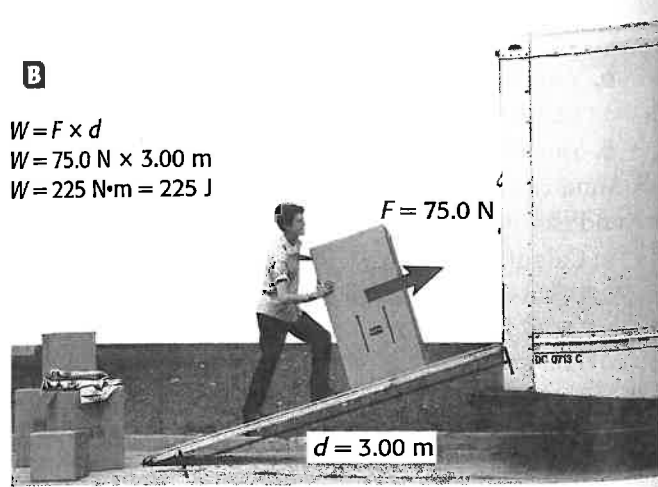
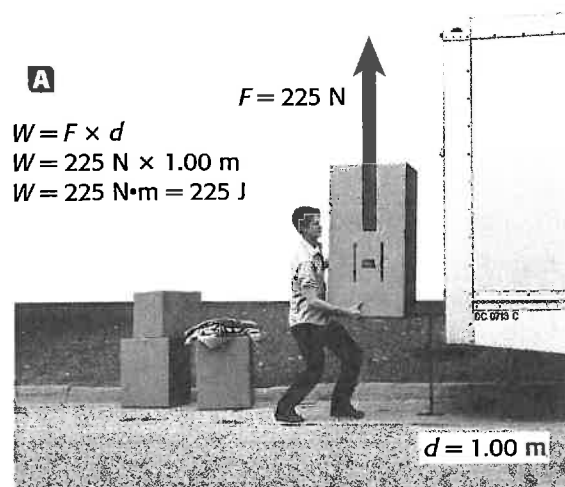

Mechanical advantage tells how much a machine multiplies force or increases distance

A ramp makes doing work easier by increasing the distance over which force is applied. But how long should the ramp be? An extremely long ramp would allow the mover to use very little force, but he would have to push the box a long distance. A very short ramp, on the other hand, would be too steep and would not help him very much.

To solve problems like this, scientists and engineers use a number that describes how much the force or distance is multiplied by a machine. This number is called the **mechanical advantage**, and it is defined as the ratio between the output force and the input force. It is also equal to the ratio between the input distance and the output distance.

Mechanical Advantage Equation

$$\text{mechanical advantage} = \frac{\text{output force}}{\text{input force}} = \frac{\text{input distance}}{\text{output distance}}$$

A machine with a mechanical advantage greater than 1 multiplies the input force. Such a machine can help you move or lift heavy objects, such as a car or a box of books. A machine with a mechanical advantage of less than 1 does not multiply force, but increases distance and speed. When you swing a baseball bat, your arms and the bat together form a machine that increases speed without multiplying force.

Math Skills

Mechanical Advantage Calculate the mechanical advantage of a ramp that is 5.0 m long and 1.5 m high.

1 List the given and unknown values.

Given: *input distance* = 5.0 m

output distance = 1.5 m

Unknown: *mechanical advantage* = ?

2 Write the equation for mechanical advantage.

Because the information we are given involves only distance, we only need part of the full equation:

$$\text{mechanical advantage} = \frac{\text{input distance}}{\text{output distance}}$$

3 Insert the known values into the equation, and solve.

$$\text{mechanical advantage} = \frac{5.0 \text{ m}}{1.5 \text{ m}} = 3.3$$



mechanical advantage a quantity that measures how much a machine multiplies force or distance

INTEGRATING



BIOLOGY

You may not do any work on a car if you try to lift it without a jack, but your body will still get tired from the effort because you are doing work on the muscles inside your body.

When you try to lift something, your muscles contract over and over in response to a series of electrical impulses from your brain. With each contraction, a tiny bit of work is done on the muscles. In just a few seconds, this can add up to thousands of contractions and a significant amount of work.

Practice HINT

- ▶ The mechanical advantage equation can be rearranged to isolate any of the variables on the left.
- ▶ For practice problem 4, you will need to rearrange the equation to isolate output force on the left.
- ▶ For practice problem 5, you will need to rearrange to isolate output distance. When rearranging, use only the part of the full equation that you need.

Practice

Mechanical Advantage

1. Calculate the mechanical advantage of a ramp that is 6.0 m long and 1.5 m high.
2. Determine the mechanical advantage of an automobile jack that lifts a 9900 N car with an input force of 150 N.
3. A sailor uses a rope and pulley to raise a sail weighing 140 N. The sailor pulls down with a force of 140 N on the rope. What is the mechanical advantage of the pulley?
4. Alex pulls on the handle of a claw hammer with a force of 15 N. If the hammer has a mechanical advantage of 5.2, how much force is exerted on a nail in the claw?
5. While rowing in a race, John pulls the handle of an oar 0.80 m on each stroke. If the oar has a mechanical advantage of 1.5, how far does the blade of the oar move through the water on each stroke?

SECTION 1 REVIEW

SUMMARY

- ▶ Work is done when a force causes an object to move. This meaning is different from the everyday meaning of *work*.
- ▶ Work is equal to force times distance. The most commonly used SI unit for work is joules.
- ▶ Power is the rate at which work is done. The SI unit for power is watts.
- ▶ Machines help people by redistributing the work put into them. They can change either the size or the direction of the input force.
- ▶ The mechanical advantage of a machine describes how much the machine multiplies force or increases distance.

1. Define work and power. How are work and power related to each other?
2. Determine if work is being done in these situations:
 - a. lifting a spoonful of soup to your mouth
 - b. holding a stack of books motionless over your head
 - c. letting a pencil fall to the ground
3. **Describe** how a ramp can make lifting a box easier without changing the amount of work being done.
4. **Critical Thinking** A short ramp and a long ramp both reach a height of 1 m. Which has a greater mechanical advantage?

Math Skills

5. How much work in joules is done by a person who uses a force of 25 N to move a desk 3.0 m?
6. A bus driver applies a force of 55.0 N to the steering wheel, which in turn applies 132 N of force on the steering column. What is the mechanical advantage of the steering wheel?
7. A student who weighs 400 N climbs a 3 m ladder in 4 s.
 - a. How much work does the student do?
 - b. What is the student's power output?
8. An outboard engine on a boat can do 1.0×10^6 J of work in 50.0 s. Calculate its power in watts. Convert your answer to horsepower (1 hp = 746 W).

Simple Machines

OBJECTIVES

- ▶ **Name** and describe the six types of simple machines.
- ▶ **Discuss** the mechanical advantage of different types of simple machines.
- ▶ **Recognize** simple machines within compound machines.

The most basic machines of all are called **simple machines**. Other machines are either modifications of simple machines or combinations of several simple machines. **Figure 4** shows examples of the six types of simple machines. Simple machines are divided into two families, the lever family and the inclined plane family.

KEY TERMS

simple machines
compound machines

simple machine one of the six basic types of machines, which are the basis for all other forms of machines

The Lever Family

To understand how levers do work, imagine using a claw hammer to pull out a nail. As you pull on the handle of the hammer, the head turns around the point where it meets the wood. The force you apply to the handle is transferred to the claw on the other end of the hammer. The claw then does work on the nail.

Figure 4
The Six Simple
Machines

The lever family

Simple lever



Pulley



Wheel and axle



Simple inclined plane

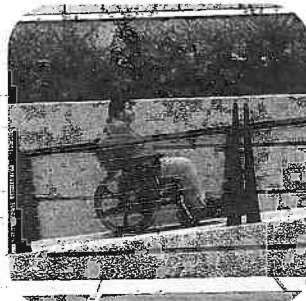

Wedge



Screw

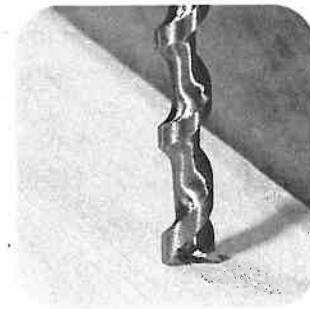

The inclined
plane family

Figure 5
The Three Classes of Levers

A All **first-class levers** have a fulcrum located between the points of application of the input and output forces.

B In a **second-class lever**, the fulcrum is at one end of the arm and the input force is applied to the other end. The wheel of a wheelbarrow is a fulcrum.

C **Third-class levers** multiply distance rather than force. As a result, they have a mechanical advantage of less than 1. The human body contains many third-class levers.

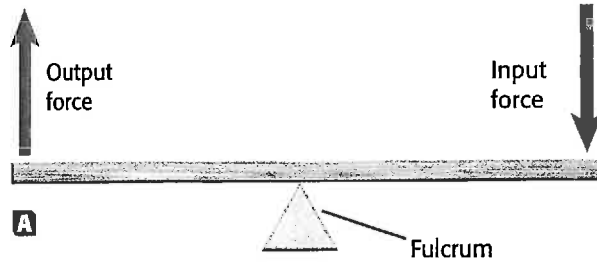

Hammer

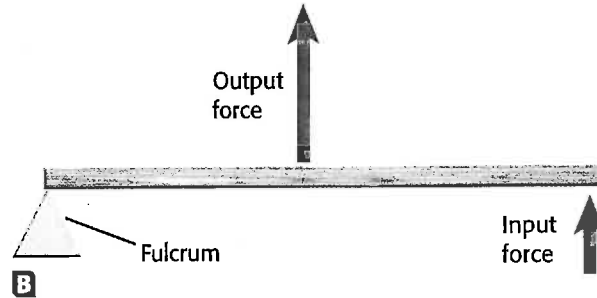

Wheelbarrow

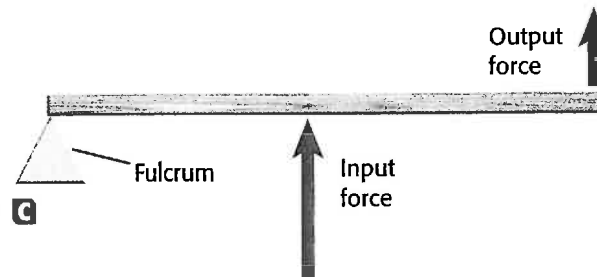

Forearm

Levers are divided into three classes

All levers have a rigid *arm* that turns around a point called the *fulcrum*. Force is transferred from one part of the arm to another. In that way, the original input force can be multiplied or redirected into an output force. Levers are divided into three classes depending on the location of the fulcrum and of the input and output forces.

Figure 5A shows a claw hammer as an example of a first-class lever. First-class levers are the most common type. A pair of pliers is made of two first-class levers joined together.

Figure 5B shows a wheelbarrow as an example of a second-class lever. Other examples of second-class levers include nutcrackers and hinged doors.

Figure 5C shows the human forearm as an example of a third-class lever. The biceps muscle, which is attached to the bone near the elbow, contracts a short distance to move the hand a large distance.

Pulleys are modified levers

You may have used pulleys to lift things, as when raising a flag to the top of a flagpole or hoisting a sail on a boat. A pulley is another type of simple machine in the lever family.

Figure 6A shows how a pulley is like a lever. The point in the middle of a pulley is like the fulcrum of a lever. The rest of the pulley behaves like the rigid arm of a first-class lever. Because the distance from the fulcrum is the same on both sides of a pulley, a single, fixed pulley has a mechanical advantage of 1.

Using moving pulleys or more than one pulley at a time can increase the mechanical advantage, as shown in **Figure 6B** and **Figure 6C**. Multiple pulleys are sometimes put together in a single unit called a *block and tackle*.

Figure 6
The Mechanical Advantage of Pulleys

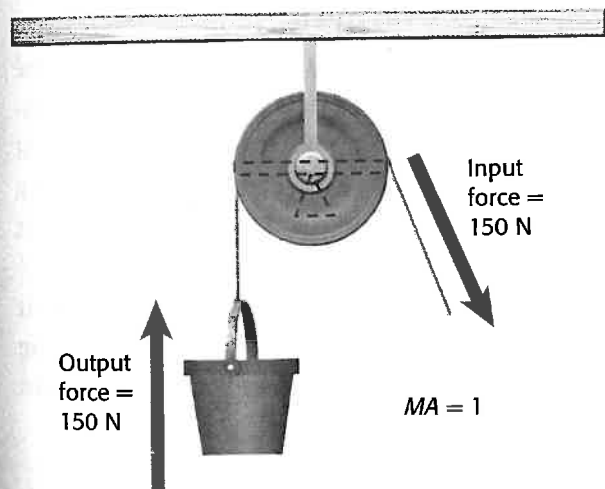

A Lifting a 150 N weight with a single, fixed pulley, the weight must be fully supported by the rope on each side of the pulley. This type of pulley has a mechanical advantage of 1.

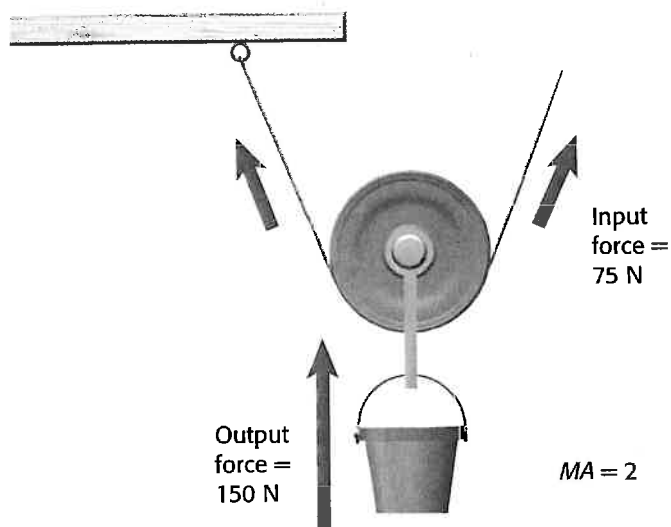

B Using a moving pulley, the 150 N force is shared by two sections of rope pulling upward. The input force on the right side of the pulley has to support only half of the weight. This pulley system has a mechanical advantage of 2.

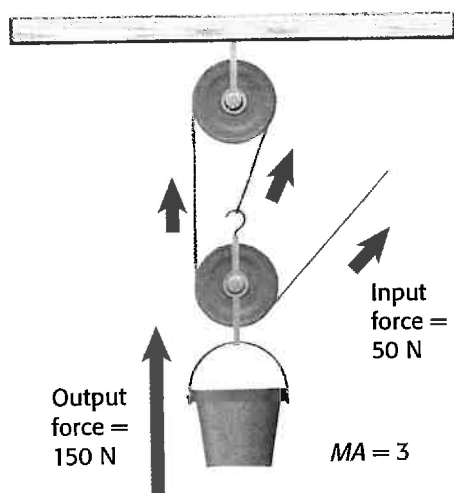

C In this arrangement of multiple pulleys, all of the sections of rope pull up against the downward force of the weight. This gives an even higher mechanical advantage.

Figure 7

How is a wheel and axle like a lever? How is it different from a pulley?

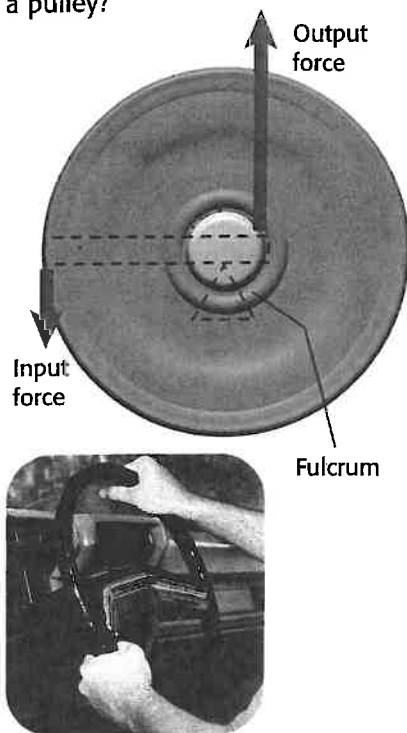

A wheel and axle is a lever or pulley connected to a shaft

The steering wheel of a car is another kind of simple machine: a wheel and axle. A wheel and axle is made of a lever or a pulley (the wheel) connected to a shaft (the axle), as shown in **Figure 7**. When the wheel is turned, the axle also turns. When a small input force is applied to the steering wheel, the force is multiplied to become a large output force applied to the steering column, which turns the front wheels of the car. Screwdrivers and cranks are other common wheel-and-axle machines.

The Inclined Plane Family

Earlier we showed how pushing an object up a ramp requires less force than lifting the same object straight up. A loading ramp is another type of simple machine, an inclined plane.

Inclined planes multiply and redirect force

When you push an object up a ramp, you apply a force to the object in a direction parallel to the ramp. The ramp then redirects this force to lift the object upward. This is why the output force of the ramp is shown in **Figure 8A** as an arrow pointing straight up. The output force is the force needed to lift the object straight up.

An inclined plane turns a small input force into a large output force by spreading the work out over a large distance. Pushing something up a long ramp that climbs gradually is easier than pushing something up a short, steep ramp.

Quick ACTIVITY

A Simple Inclined Plane

1. Make an inclined plane out of a board and a stack of books.
2. Tie a string to an object that is heavy but has low friction, such as a metal toy car or a roll of wire. Use the string to pull the object up the plane.
3. Still using the string, try to lift the object straight up through the same distance.
4. Which action required more force? In which case did you do more work?

Figure 8 The Inclined Plane Family

A An inclined plane changes both the magnitude and the direction of force.

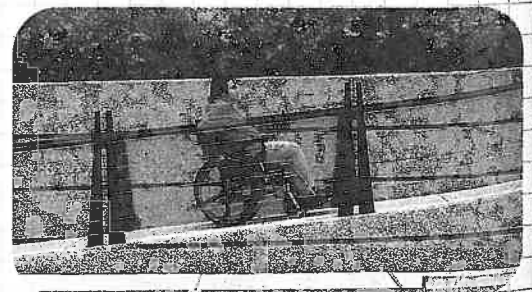
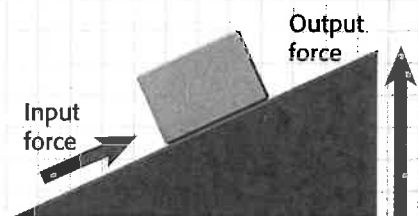

A wedge is a modified inclined plane

When an ax blade or a splitting wedge hits a piece of wood, it pushes through the wood and breaks it apart, as shown in **Figure 8B**. An ax blade is an example of a wedge, another kind of simple machine in the inclined plane family. A wedge functions like two inclined planes back to back. Using a wedge is like pushing a ramp instead of pushing an object up the ramp. A wedge turns a single downward force into two forces directed out to the sides. Some types of wedges, such as nails, are used as fasteners.

A screw is an inclined plane wrapped around a cylinder

A type of simple machine that you probably use often is a screw. The threads on a screw look like a spiral inclined plane. In fact, a screw is an inclined plane wrapped around a cylinder, as shown in **Figure 8C**. Like pushing an object up a ramp, tightening a screw with gently sloping threads requires a small force acting over a large distance. Tightening a screw with steeper threads requires more force. Jar lids are screws that people use every day. Spiral staircases are also common screws.

B A wedge turns a downward force into two forces directed out to the sides.

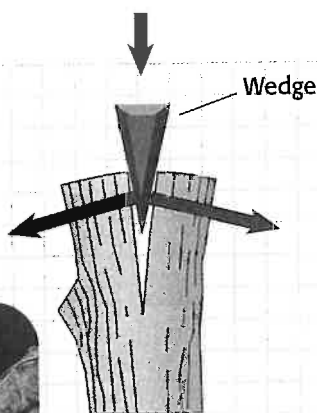

Connection to SOCIAL STUDIES

The ancient Egyptians built dozens of large stone pyramids as tombs for the bodies of kings and queens. The largest of these is the pyramid of Khufu at Giza, also called the Great Pyramid. It is made of more than 2 million blocks of stone. These blocks have an average weight of 2.5 tons, and the largest blocks weigh 15 tons. How did the Egyptians get these huge stones onto the pyramid?



Making the Connection

1. The Great Pyramid is about 140 m tall. How much work would be required to raise an average-sized pyramid block to this height? ($2.5 \text{ tons} = 2.2 \times 10^4 \text{ N}$)
2. If the Egyptians used ramps with a mechanical advantage of 3, then an average block could be moved with a force of $7.3 \times 10^3 \text{ N}$. If one person can pull with a force of 525 N, how many people would it take to pull an average block up such a ramp?

C A screw is an inclined plane wrapped around a cylinder.

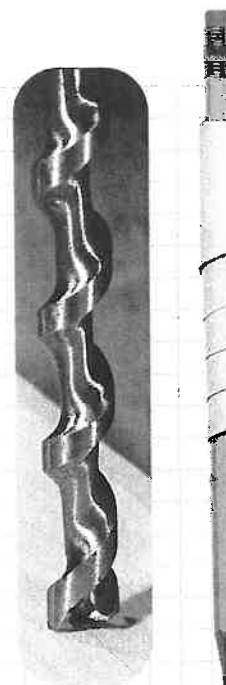

- compound machine**
 a machine made of more than one simple machine

Compound Machines

Many devices that you use every day are made of more than one simple machine. A machine that combines two or more simple machines is called a **compound machine**. A pair of scissors, for example, uses two first class levers joined at a common fulcrum; each lever arm has a wedge that cuts into the paper. Most car jacks use a lever in combination with a large screw.

Of course, many machines are much more complex than these. How many simple machines can you identify in the bicycle shown in **Figure 9**? How many can you identify in a car?



Figure 9

A bicycle is made of many simple machines.

SECTION 2 REVIEW

SUMMARY

- ▶ The most basic machines are called simple machines. There are six types of simple machines in two families.
- ▶ Levers have a rigid arm and a fulcrum. There are three classes of levers.
- ▶ Pulleys and wheel-and-axle machines are also in the lever family.
- ▶ The inclined plane family includes inclined planes, wedges, and screws.
- ▶ Compound machines are made of two or more simple machines.

1. **List** the six types of simple machines.
2. **Identify** the kind of simple machine represented by each of these examples:
 - a. a drill bit
 - b. a skateboard ramp
 - c. a boat oar
3. **Describe** how a lever can increase the force without changing the amount of work being done.
4. **Explain** why pulleys are in the lever family.
5. **Compare** the mechanical advantage of a long, thin wedge with that of a short, wide wedge. Which is greater?
6. **Critical Thinking** Can an inclined plane have a mechanical advantage of less than 1?
7. **Critical Thinking** Using the principle of a lever, explain why it is easier to open a door by pushing near the knob than by pushing near the hinges. What class of lever is a door?
8. **Creative Thinking** Choose a compound machine that you use every day, and identify the simple machines that it contains.

What Is Energy?

OBJECTIVES

- ▶ **Explain** the relationship between energy and work.
- ▶ **Define** *potential energy* and *kinetic energy*.
- ▶ **Calculate** kinetic energy and gravitational potential energy.
- ▶ **Distinguish** between mechanical and nonmechanical energy.

The world around you is full of energy. When you see a flash of lightning and hear a thunderclap, you are observing light and sound energy. When you ride a bicycle, you have energy just because you are moving. Even things that are sitting still have energy waiting to be released. We use other forms of energy, like nuclear energy and electrical energy, to power things in our world, from submarines to flashlights. Without energy, living organisms could not survive. Our bodies use a great deal of energy every day just to stay alive.

Energy and Work

When you stretch a slingshot, as shown in **Figure 10**, you are doing work, and you transfer energy to the elastic band. When the elastic band snaps back, it may in turn transfer that energy again by doing work on a stone in the slingshot. Whenever work is done, energy is transformed or transferred to another system. In fact, one way to define energy is as the ability to do work.

Energy is measured in joules

While work is done only when an object experiences a change in its position or motion, energy can be present in an object or a system when nothing is happening at all. But energy can be observed only when it is transferred from one object or system to another, as when a slingshot transfers the energy from its elastic band to a stone in the sling.

The amount of energy transferred from the slingshot can be measured by how much work is done on the stone. Because energy is a measure of the ability to do work, energy and work are expressed in the same units—joules.

KEY TERMS

potential energy
kinetic energy
mechanical energy

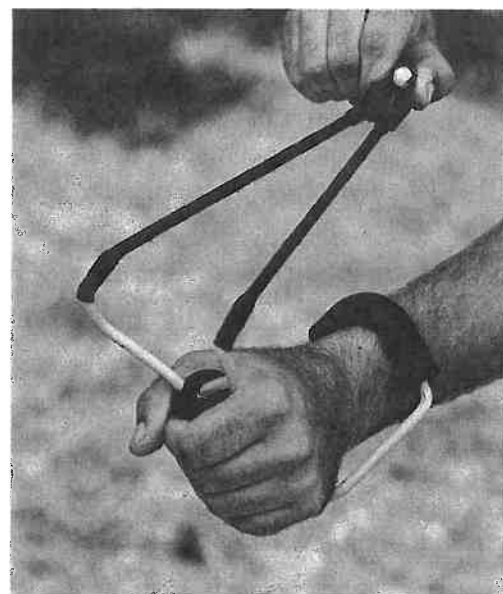

Figure 10

A stretched slingshot has the ability to do work.



Figure 11

This apple has gravitational potential energy. The energy results from the gravitational attraction between the apple and Earth.

■ **potential energy** the energy that an object has because of the position, shape, or condition of the object

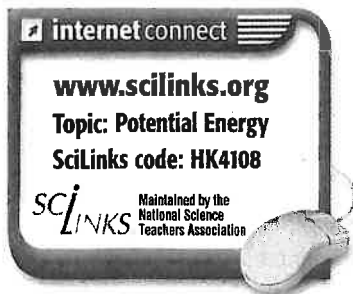

Potential Energy

Stretching a rubber band requires work. If you then release the stretched rubber band, it will fly away from your hand. The energy used to stretch the rubber band is stored as potential energy so that it can do work at a later time. But where is the energy between the time you do work on the rubber band and the time you release it?

Potential energy is stored energy

A stretched rubber band stores energy in a form called **potential energy**. Potential energy is sometimes called energy of position because it results from the relative positions of objects in a system. The rubber band has potential energy because the two ends of the band are far away from each other. The energy stored in any type of stretched or compressed elastic material, such as a spring or a bungee cord, is called *elastic potential energy*.

The apple in **Figure 11** will fall if the stem breaks off the branch. The energy that could potentially do work on the apple results from its position above the ground. This type of stored energy is called *gravitational potential energy*. Any system of two or more objects separated by a distance contains gravitational potential energy resulting from the gravitational attraction between the objects.

Gravitational potential energy depends on both mass and height

An apple at the top of the tree has more gravitational potential energy with respect to the Earth than a similar apple on a lower branch. But if two apples of different masses are at the same height, the heavier apple has more gravitational potential energy than the lighter one.

Because it results from the force of gravity, gravitational potential energy depends both on the mass of the objects in a system and on the distance between them.

Gravitational Potential Energy Equation

$$\text{grav. PE} = \text{mass} \times \text{free-fall acceleration} \times \text{height}$$
$$\text{PE} = mgh$$

In this equation, notice that mg is the weight of the object in newtons, which is the same as the force on the object due to gravity. So this equation is really just a calculation of force times distance, like the work equation.

Height can be relative

The height used in the equation for gravitational potential energy is usually measured from the ground. However, in some cases, a relative height might be more important. For example, if an apple were in a position to fall into a bird's nest on a lower branch, the apple's height above the nest could be used to calculate the apple's potential energy relative to the nest.

Math Skills

Gravitational Potential Energy A 65 kg rock climber ascends a cliff. What is the climber's gravitational potential energy at a point 35 m above the base of the cliff?

1 List the given and unknown values.

Given: mass, $m = 65$ kg
height, $h = 35$ m
free-fall acceleration, $g = 9.8$ m/s²

Unknown: gravitational potential energy, $PE = ?$ J

2 Write the equation for gravitational potential energy.

$$PE = mgh$$

3 Insert the known values into the equation, and solve.

$$PE = (65 \text{ kg})(9.8 \text{ m/s}^2)(35 \text{ m})$$
$$PE = 2.2 \times 10^4 \text{ kg} \cdot \text{m}^2/\text{s}^2 = 2.2 \times 10^4 \text{ J}$$

Practice

Gravitational Potential Energy

- Calculate the gravitational potential energy in the following systems:
 - a car with a mass of 1200 kg at the top of a 42 m high hill
 - a 65 kg climber on top of Mount Everest (8800 m high)
 - a 0.52 kg bird flying at an altitude of 550 m
- Lake Mead, the reservoir above Hoover Dam, has a surface area of approximately 640 km². The top 1 m of water in the lake weighs about 6.3×10^{12} N. The dam holds that top layer of water 220 m above the river below. Calculate the gravitational potential energy of the top 1 m of water in Lake Mead.
- A science student holds a 55 g egg out a window. Just before the student releases the egg, the egg has 8.0 J of gravitational potential energy with respect to the ground. How far is the student's arm from the ground in meters? (**Hint:** Convert the mass to kilograms before solving.)
- A diver has 3400 J of gravitational potential energy after stepping up onto a diving platform that is 6.0 m above the water. What is the diver's mass in kilograms?

Practice HINT

- The gravitational potential energy equation can be rearranged to isolate height on the left.

$$mgh = PE$$

Divide both sides by mg , and cancel.

$$\frac{mgh}{mg} = \frac{PE}{mg}$$

$$h = \frac{PE}{mg}$$

- You will need this version of the equation for practice problem 3.
- For practice problem 4, you will need to rearrange the equation to isolate mass on the left. When solving these problems, use $g = 9.8$ m/s².

Kinetic Energy

Once an apple starts to fall from the branch of a tree, as in **Figure 12A**, it has the ability to do work. Because the apple is moving, it can do work when it hits the ground or lands on the head of someone under the tree. The energy that an object has because it is in motion is called **kinetic energy**.

■ **kinetic energy** the energy of a moving object due to the object's motion

VOCABULARY Skills Tip

Kinetic comes from the Greek word *kinetikos*, which means "motion."

Kinetic energy depends on mass and speed

A falling apple can do more work than a cherry falling at the same speed. That is because the kinetic energy of an object depends on the object's mass.

An apple that is moving at 10 m/s can do more work than an apple moving at 1 m/s can. As an apple falls, it accelerates. The kinetic energy of the apple increases as it speeds up. In fact, the kinetic energy of a moving object depends on the square of the object's speed.

Kinetic Energy Equation

$$\text{kinetic energy} = \frac{1}{2} \times \text{mass} \times \text{speed squared}$$
$$KE = \frac{1}{2}mv^2$$

Figure 12B shows a graph of kinetic energy versus speed for a falling apple that weighs 1.0 N. Notice that kinetic energy is expressed in joules. Because kinetic energy is calculated using both mass and speed squared, the base units are $\text{kg} \cdot \text{m}^2/\text{s}^2$, which are equivalent to joules.

Figure 12

A A falling apple can do work on the ground underneath—or on someone's head.

B A small increase in the speed of an apple results in a large increase in kinetic energy.

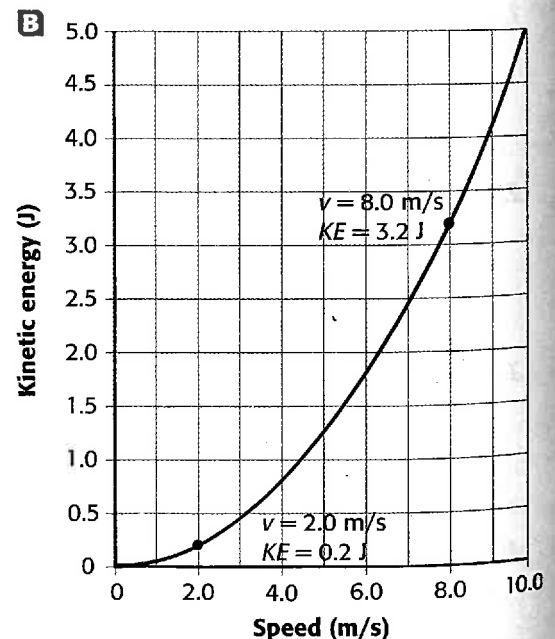

Kinetic energy depends on speed more than mass

The line on the graph of kinetic energy versus speed curves sharply upward as speed increases. At one point, the speed is 2.0 m/s and the kinetic energy is 0.20 J. At another point, the speed has increased four times to 8.0 m/s. But the kinetic energy has increased 16 times, to 3.2 J. In the kinetic energy equation, speed is squared, so a small increase in speed produces a large increase in kinetic energy.

You may have heard that car crashes are much more dangerous at speeds above the speed limit. The kinetic energy equation provides a scientific reason for that fact. Because a car has much more kinetic energy at higher speeds, it can do much more work—which means much more damage—in a collision.

Math Skills

Kinetic Energy What is the kinetic energy of a 44 kg cheetah running at 31 m/s?

1 List the given and unknown values.

Given: mass, $m = 45 \text{ kg}$
speed, $v = 31 \text{ m/s}$

Unknown: kinetic energy, $KE = ? \text{ J}$

2 Write the equation for kinetic energy.

kinetic energy = $\frac{1}{2} \times \text{mass} \times \text{speed squared}$

$$KE = \frac{1}{2}mv^2$$

3 Insert the known values into the equation, and solve.

$$KE = \frac{1}{2}(44 \text{ kg})(31 \text{ m/s})^2$$

$$KE = 2.1 \times 10^4 \text{ kg} \cdot \text{m}^2/\text{s}^2 = 2.1 \times 10^4 \text{ J}$$

Practice

Kinetic Energy

- Calculate the kinetic energy in joules of a 1500 kg car moving at the following speeds:
 - 29 m/s
 - 18 m/s
 - 42 km/h (**Hint:** Convert the speed to meters per second before substituting into the equation.)
- A 35 kg child has 190 J of kinetic energy after sledding down a hill. What is the child's speed in meters per second at the bottom of the hill?
- A bowling ball traveling 2.0 m/s has 16 J of kinetic energy. What is the mass of the bowling ball in kilograms?

boom

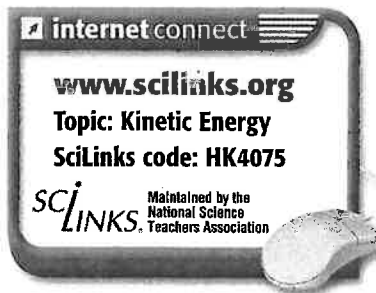

Practice HINT

- The kinetic energy equation can be rearranged to isolate speed on the left.

$$\frac{1}{2}mv^2 = KE$$

Multiply both sides by $\frac{2}{m}$.

$$\left(\frac{2}{m}\right) \times \frac{1}{2}mv^2 = \left(\frac{2}{m}\right) \times KE$$

$$v^2 = \frac{2KE}{m}$$

Take the square root of each side.

$$\sqrt{v^2} = \sqrt{\frac{2KE}{m}}$$

$$v = \sqrt{\frac{2KE}{m}}$$

You will need this version of the equation for Practice Problem 2.

- For Practice Problem 3, you will need to use the equation rearranged with mass isolated on the left:

$$m = \frac{2KE}{v^2}$$

■ **mechanical energy**
the amount of work an object can do because of the object's kinetic and potential energies

Other Forms of Energy

Apples have potential energy when they are hanging on a branch above the ground, and they have kinetic and potential energy when they are falling. The sum of the potential energy and the kinetic energy in a system is called **mechanical energy**. Mechanical energy can also be thought of as the amount of work an object can do because of the object's kinetic and potential energies.

Apples can also give you energy when you eat them. What kind of energy is that? In almost every system, there are hidden forms of energy that are related to the motion and arrangement of atoms that make up the objects in the system.

Energy that lies at the level of atoms and that does not affect motion on a large scale is sometimes called *nonmechanical energy*. However, a close look at the different forms of energy in a system usually reveals that they are in most cases just special forms of kinetic or potential energy.

Atoms and molecules have kinetic energy

You have learned that atoms and molecules are constantly in motion. Therefore, these tiny particles have kinetic energy. Like a bowling ball hitting pins, kinetic energy is transferred between particles through collisions. The average kinetic energy of particles in an object increases as the object gets hotter and decreases as it cools down. In another chapter, you will learn more about how the kinetic energy of particles relates to heat and temperature.

Figure 13 shows the motion of atoms in two parts of a horseshoe at different temperatures. In both parts, the iron atoms inside the horseshoe are vibrating. The atoms in the hotter part of the horseshoe are vibrating more rapidly than the atoms in the cooler part, so they have greater kinetic energy.

If a scientist wanted to analyze the motion of a horseshoe in a game of "horseshoes," the motion of particles inside the shoes would not be important. For the sake of that study, the energy due to the motion of the atoms would be considered nonmechanical energy.

However, if the same scientist wanted to study the change in the properties of iron when heated in a blacksmith's shop, the motion of the atoms would become significant to the study, and the kinetic energy of the particles within the horseshoe would then be viewed as mechanical energy.

Figure 13

The atoms in a hot object, such as this horseshoe, have kinetic energy. The kinetic energy is related to the object's temperature.

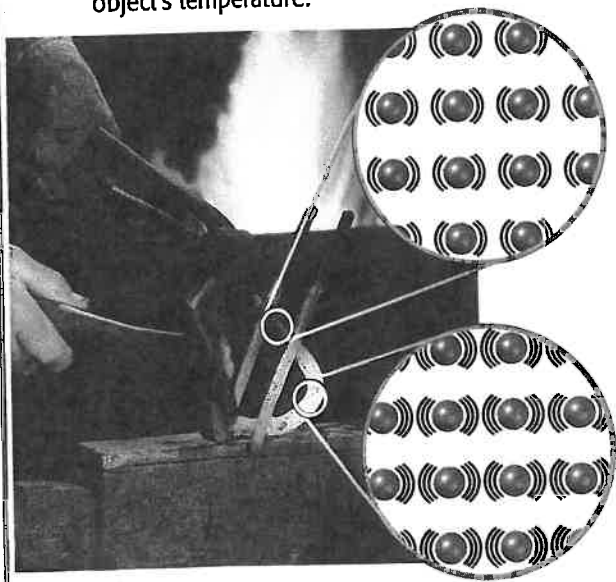

Chemical reactions involve potential energy

In a chemical reaction, bonds between atoms break apart. When the atoms bond together again in a new pattern, a different substance is formed. Both the formation of bonds and the breaking of bonds involve changes in energy. The amount of *chemical energy* associated with a substance depends in part on the relative positions of the atoms it contains.

Because chemical energy depends on position, it is a kind of potential energy. Reactions that release energy involve a decrease in the potential energy within substances. For example, when a match burns, as shown in **Figure 14**, the release of stored energy from the match head produces light and a small explosion of hot gas.

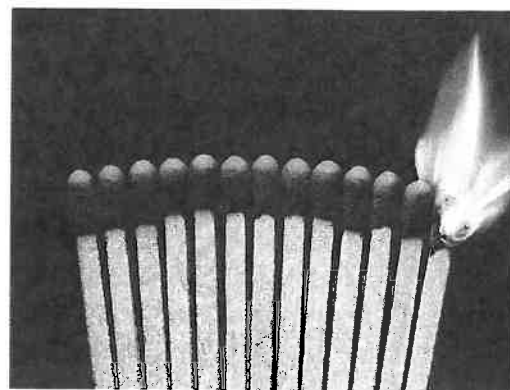

Figure 14

When a match burns, the chemical energy stored inside the head of the match is released, producing light and a small explosion of hot gas.

Living things get energy from the sun

Where do you get the energy you need to live? It comes in the form of chemical energy stored in the food you eat. But where did that energy come from? When you eat a meal, you are eating either plants or animals, or both. Animals also eat plants or other animals, or both. At the bottom of the food chain are plants and algae that derive their energy directly from sunlight.

Plants use *photosynthesis* to turn the energy in sunlight into chemical energy. This energy is stored in sugars and other organic molecules that make up cells in living tissue. When your body needs energy, some of these organic molecules are broken down through *respiration*. Respiration releases the energy your body needs to live and do work.

REAL WORLD APPLICATIONS

The Energy in Food

We get energy from the food we eat. This energy is often measured by another unit, the Calorie. One Calorie is equivalent to 4186 J.

Applying Information

1. Look at the nutrition label on this "energy bar." How many Calories of energy does the bar contain?



2. Calculate how many joules of energy the bar contains by multiplying the number of Calories by the conversion factor of 4186 J/Cal.

3. An average person needs to take in about 10 million joules of energy every day. How many energy bars would you have to eat to get this much energy?

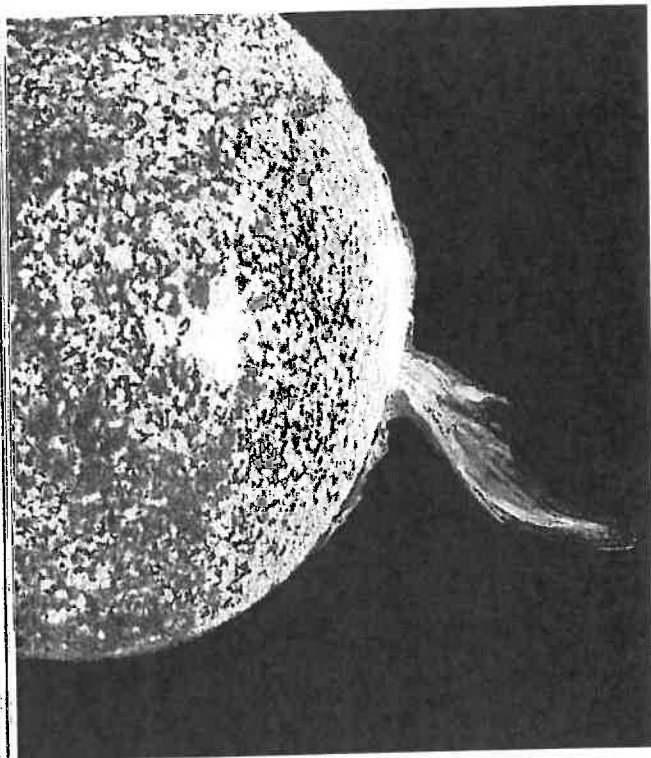

Figure 15

The nuclei of atoms contain enormous amounts of energy. The sun is fueled by nuclear fusion reactions in its core.

The sun gets energy from nuclear reactions

The sun, shown in **Figure 15**, not only gives energy to living things but also keeps our whole planet warm and bright. And the energy that reaches Earth from the sun is only a small portion of the sun's total energy output. How does the sun produce so much energy?

The sun's energy comes from nuclear fusion, a type of reaction in which light atomic nuclei combine to form a heavier nucleus. Nuclear power plants use a different process, called nuclear fission, to release nuclear energy. In fission, a single heavy nucleus is split into two or more lighter nuclei. In both fusion and fission, small quantities of mass are converted into large quantities of energy.

You have learned that mass is converted to energy during nuclear reactions. This nuclear energy is a kind of potential energy stored by the forces holding subatomic particles together in the nuclei of atoms.

Electricity is a form of energy

The lights and appliances in your home are powered by another form of energy, electricity. Electricity results from the flow of charged particles through wires or other conducting materials. Moving electrons can increase the temperature of a wire and cause it to glow, as in a light bulb. Moving electrons also create magnetic fields, which can do work to power a motor or other devices. The lightning shown in **Figure 16** is caused by electrons traveling through the air between the ground and a thundercloud.

Figure 16

Electrical energy is derived from the flow of charged particles, as in a bolt of lightning or in a wire. We can harness electricity to power appliances in our homes.

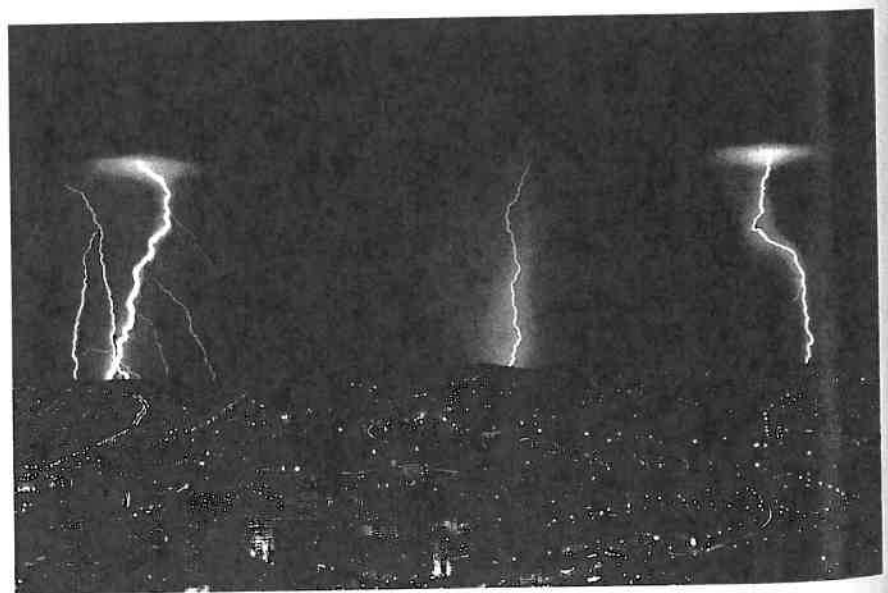

Light can carry energy across empty space

An asphalt surface on a bright summer day is hotter where light is shining directly on it than it is in the shade. Light energy travels from the sun to Earth across empty space in the form of *electromagnetic waves*.

A beam of white light can be separated into a color spectrum, as shown in **Figure 17**. Light toward the blue end of the spectrum carries more energy than light toward the red end.

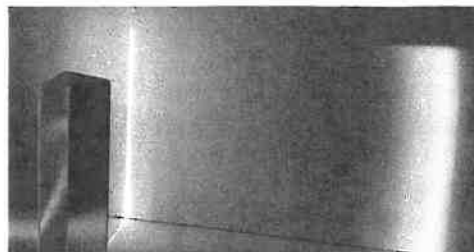

Figure 17

Light is made of electromagnetic waves that carry energy across empty space.

SECTION 3 REVIEW

SUMMARY

- ▶ Energy is the ability to do work.
- ▶ Like work, energy is measured in joules.
- ▶ Potential energy is stored energy.
- ▶ Elastic potential energy is stored in any stretched or compressed elastic material.
- ▶ The gravitational potential energy of an object is determined by its mass, its height, and g , the free-fall acceleration due to gravity.
 $PE = mgh$.
- ▶ An object's kinetic energy, or energy of motion, is determined by its mass and speed. $KE = \frac{1}{2}mv^2$.
- ▶ Potential energy and kinetic energy are forms of mechanical energy.
- ▶ In addition to mechanical energy, most systems contain nonmechanical energy.
- ▶ Nonmechanical energy does not usually affect systems on a large scale.

1. **List** three different forms of energy.
2. **Explain** how energy is different from work.
3. **Explain** the difference between potential energy and kinetic energy.
4. **Determine** what form or forms of energy apply to each of the following situations, and specify whether each form is mechanical or nonmechanical:
 - a. a Frisbee flying through the air
 - b. a hot cup of soup
 - c. a wound clock spring
 - d. sunlight
 - e. a boulder sitting at the top of a cliff
5. **Critical Thinking** Water storage tanks are usually built on towers or placed on hilltops. Why?
6. **Creative Thinking** Name one situation in which gravitational potential energy might be useful, and name one situation where it might be dangerous.

Math Skills

7. Calculate the gravitational potential energy of a 93.0 kg sky diver who is 550 m above the ground.
8. What is the kinetic energy in joules of a 0.02 kg bullet traveling 300 m/s?
9. Calculate the kinetic or potential energy in joules for each of the following situations:
 - a. a 2.5 kg book held 2.0 m above the ground
 - b. a 15 g snowball moving through the air at 3.5 m/s
 - c. a 35 kg child sitting at the top of a slide that is 3.5 m above the ground
 - d. an 8500 kg airplane flying at 220 km/h

Conservation of Energy

KEY TERM

efficiency

OBJECTIVES

- ▶ **Identify** and describe transformations of energy.
- ▶ **Explain** the law of conservation of energy.
- ▶ **Discuss** where energy goes when it seems to disappear.
- ▶ **Analyze** the efficiency of machines.

Figure 18

The tallest roller coaster in the world is the Fujiyama, in Fujiyama Highland Park, Japan. It spans 70 m from its highest to lowest points.



Imagine you are sitting in the front car of a roller coaster, such as the one shown in **Figure 18**. The car is pulled slowly up the first hill by a conveyor belt. When you reach the crest of the hill, you are barely moving. Then you go over the edge and start to race downward, speeding faster and faster until you reach the bottom of the hill. The wheels are roaring along the track. You continue to travel up and down through a series of smaller humps, twists, and turns. Finally, you climb another hill almost as big as the first, drop down again, and then coast to the end of the ride.

Energy Transformations

In the course of a roller coaster ride, energy changes form many times. You may not have noticed the conveyor belt at the beginning, but in terms of energy it is the most important part of the ride. All of the energy required for the entire ride comes from work done by the conveyor belt as it lifts the cars and the passengers up the first hill.

The energy from that initial work is stored as gravitational potential energy at the top of the first hill. After that, the energy goes through a series of transformations, or changes, turning into kinetic energy and turning back into potential energy. A small quantity of this energy is transferred as heat to the wheels and as vibrations that produce a roaring sound in the air. But whatever form the energy takes during the ride, it is all there from the very beginning.

Figure 19

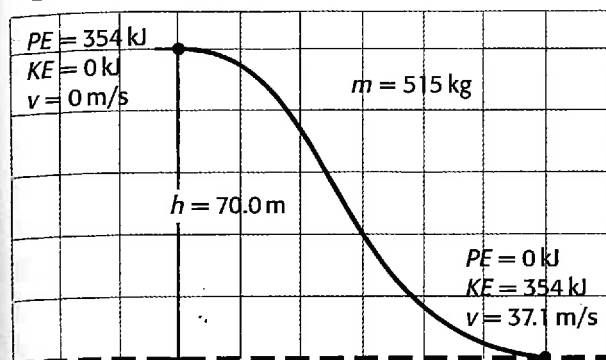

A As a car goes down a hill on a roller coaster, potential energy changes to kinetic energy.

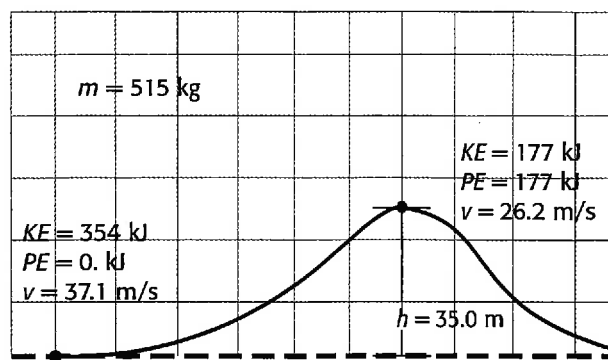

B At the top of this small hill, half the kinetic energy has become potential energy. The rest of the kinetic energy carries the car over the crest of the hill at high speed.

Potential energy can become kinetic energy

Almost all of the energy of a car on a roller coaster is potential energy at the top of a tall hill. The potential energy gradually changes to kinetic energy as the car accelerates downward. At the bottom of the lowest hill, the car has a maximum of kinetic energy and a minimum of potential energy.

Figure 19A shows the potential energy and kinetic energy of a car at the top and the bottom of the biggest hill on the Fujiyama roller coaster. Notice that the system has the same amount of energy, 354 kJ, whether the car is at the top or the bottom of the hill. That is because all of the gravitational potential energy at the top changes to kinetic energy as the car goes down the hill. When the car reaches the lowest point, the system has no potential energy because the car cannot go any lower.

Kinetic energy can become potential energy

When the car is at the lowest point on the roller coaster, it has no more potential energy, but it has a lot of kinetic energy. This kinetic energy can do the work to carry the car up another hill. As the car climbs the hill, the car slows down, decreasing its kinetic energy. Where does that energy go? Most of it turns back into potential energy as the height of the car increases.

At the top of a smaller hill, the car will still have some kinetic energy, along with some potential energy, as shown in **Figure 19B**. The kinetic energy will carry the car forward over the crest of the hill. Of course, the car could not climb a hill taller than the first one without an extra boost. The car does not have enough energy.

internet connect

www.scilinks.org
Topic: Energy Transformations
SciLinks code: HK4049

sciLINKS
 Maintained by the
 National Science
 Teachers Association

Energy transformations explain the flight of a ball

The relationship between potential energy and kinetic energy can explain motion in many different situations. Let's look at some other examples.

A tennis player tosses a 0.05 kg tennis ball into the air to set up for a serve, as shown in **Figure 20**. He gives the ball 0.5 J of kinetic energy, and it travels straight up. As the ball rises higher, the kinetic energy is converted to potential energy. The ball will keep rising until all the kinetic energy is gone. At its highest point, the ball has 0.5 J of potential energy. As the ball falls down again, the potential energy changes back to kinetic energy.

Imagine that a tennis trainer wants to know how high the ball will go when it is given 0.5 J of initial kinetic energy by a tennis player. The trainer could make a series of calculations using force and acceleration, but in this case using the concept of energy transformations is easier. The trainer knows that the ball's initial kinetic energy is 0.5 J and that its mass is 0.05 kg. To find out how high the ball will go, the trainer has to find the point where the potential energy equals its initial kinetic energy, 0.5 J. Using the equation for gravitational potential energy, the height turns out to be 1 m above the point that the tennis player releases the ball.

Figure 20

The kinetic energy of the ball at the bottom of its path equals the potential energy at the top of the path.

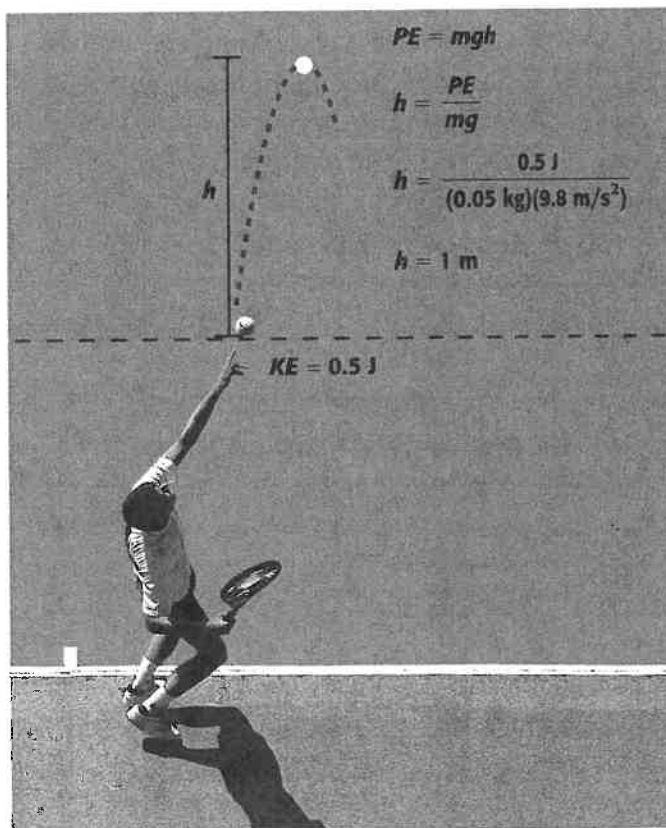

Energy transformations explain a bouncing ball

Before a serve, a tennis player usually bounces the ball a few times while building concentration. The motion of a bouncing ball can also be explained using energy principles. As the tennis player throws the ball down, he adds kinetic energy to the potential energy the ball has at the height of her hand. The kinetic energy of the ball then increases steadily as the ball falls because the potential energy is changing to kinetic energy.

When the ball hits the ground, there is a sudden energy transformation as the kinetic energy of the ball changes to elastic potential energy stored in the compressed tennis ball. The elastic potential energy then quickly changes back to kinetic energy as the ball bounces upward.

If all of the kinetic energy in the ball changed to elastic potential energy, and that elastic potential energy all changed back to kinetic energy during the bounce, the ball would bounce up to the tennis player's hand. Its speed on return would be exactly the same as the speed at which it was thrown down. If the ball were dropped instead of thrown down, it would bounce up to the same height from which it was dropped.

Mechanical energy can change to other forms of energy

If changes from kinetic energy to potential energy and back again were always complete, then balls would always bounce back to the same height they were dropped from and cars on roller coasters would keep gliding forever. But that is not the way things really happen.

When a ball bounces on the ground, not all of the kinetic energy changes to elastic potential energy. Some of the kinetic energy compresses the air around the ball, making a sound, and some of the kinetic energy makes the ball, the air, and the ground slightly hotter. Because these other forms of energy are not directly due to the motion or position of the ball, they can be considered nonmechanical energy. With each bounce, the ball loses some mechanical energy, as shown in **Figure 21**.

Likewise, a car on a roller coaster cannot keep moving up and down the track forever. The total mechanical energy of a car on a roller coaster constantly decreases due to friction and air resistance. This energy does not just disappear though. Some of it increases the temperature of the track, the car's wheels, and the air. Some of the energy compresses the air, making a roaring sound. Often, when energy seems to disappear, it has really just changed to a nonmechanical form.

Quick ACTIVITY

Energy Transfer

1. Flex a piece of thick wire or part of a coat hanger back and forth about 10 times with your hands. Are you doing work?
2. After flexing the wire, cautiously touch the part of the wire where you bent it. Does the wire feel hot? What happened to the energy you put into it?

Figure 21

With each bounce of a tennis ball, some of the mechanical energy changes to nonmechanical energy.

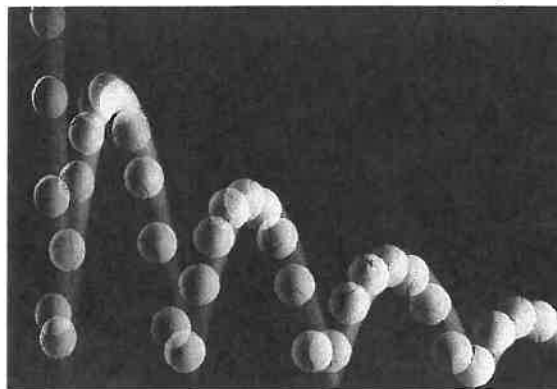

The Law of Conservation of Energy

In our study of machines, we saw that the work done on a machine is equal to the work that it can do. Similarly, in our study of the roller coaster, we found that the energy present at the beginning of the ride is present throughout the ride and at the end of the ride, although the energy continually changes form. The energy in each system does not appear out of nowhere and never just disappears.

This simple observation is based on one of the most important principles in all of science—the law of conservation of energy. Here is the law in its simplest form.

Energy cannot be created or destroyed.

In a mechanical system such as a roller coaster or a swinging pendulum, the energy in the system at any time can be calculated by adding the kinetic and potential energy to get the total mechanical energy. The law of conservation of energy requires that at any given time, the total energy should be the same.

INTEGRATING



COMPUTERS AND TECHNOLOGY

In order for a flashlight to work, there must be a supply of energy.

A flashlight battery contains different chemicals that can react with each other to release energy. When the flashlight is turned on, chemical potential energy changes to electrical energy, and electrons begin to flow through a wire attached to the battery. Inside the bulb, the wire filament begins to glow, and the energy is transformed into light energy.

After the flashlight has been used for a certain amount of time, the battery will run out of energy. It will have to be replaced or recharged.

Energy doesn't appear out of nowhere

Energy cannot be created from nothing. Imagine a girl jumping on a trampoline. After the first bounce, she rises to a height of 0.5 m. After the second bounce, she rises to a height of 1 m. Because she has greater gravitational potential energy after the second bounce, we must conclude that she added energy to her bounce by pushing with her legs. Whenever the total energy in a system increases, it must be due to energy that enters the system from an external source.

Energy doesn't disappear

Because mechanical energy can change to nonmechanical energy due to friction, air resistance, and other factors, tracing the flow of energy in a system can be difficult. Some of the energy may leak out of the system into the surrounding environment, as when the roller coaster produces sound as it compresses the air. But none of the energy disappears; it just changes form.

Scientists study energy systems

Energy has many different forms and can be found almost everywhere. Accounting for all of the energy in a given situation can be complicated. To make studying a situation easier, scientists often limit their view to a small area or a small number of objects. These boundaries define a system.

Systems may be open or closed

A system might include a gas burner and a pot of water. A scientist could study the flow of energy from the burner into the pot and ignore the small amount of energy going into the pot from the lights in the room, from a hand touching the pot, and so on.

When the flow of energy into and out of a system is small enough that it can be ignored, the system is called a *closed system*. Most systems are *open systems*, which exchange energy with the space that surrounds them. Earth is an open system, as shown in **Figure 22**. Is your body an open or closed system?

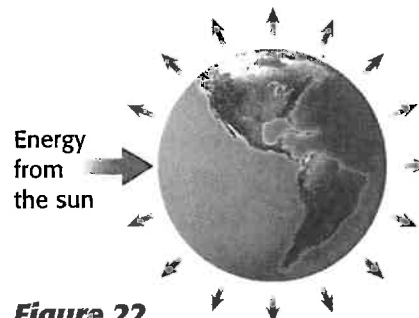

Figure 22
Earth is an open system because it receives energy from the sun and radiates some of its own energy out into space.

Quick Lab

Is energy conserved in a pendulum?

Materials

1–1.5 m length of string

level

nail or hook in the wall
above a chalkboard

pencil with an eraser

pendulum bob

meterstick

1. Hang the pendulum bob from the string in front of a chalkboard. On the board, draw the diagram as shown in the photograph at right. Use the meterstick and the level to make sure the horizontal line is parallel to the ground.
2. Pull the pendulum ball back to the "X." Make sure everyone is out of the way; then release the pendulum and observe its motion. How high does the pendulum swing on the other side?
3. Let the pendulum swing back and forth several times. How many swings does the pendulum make before the ball noticeably fails to reach its original height?
4. Stop the pendulum and hold it again at the "X" marked on the board. Have another student place the eraser end of a pencil on the intersection of the horizontal and vertical lines. Make sure everyone is out of the way again, especially the student holding the pencil.
5. Release the pendulum again. This time its motion will be altered halfway through the swing as the string hits the pencil. How high does the pendulum swing now? Why?

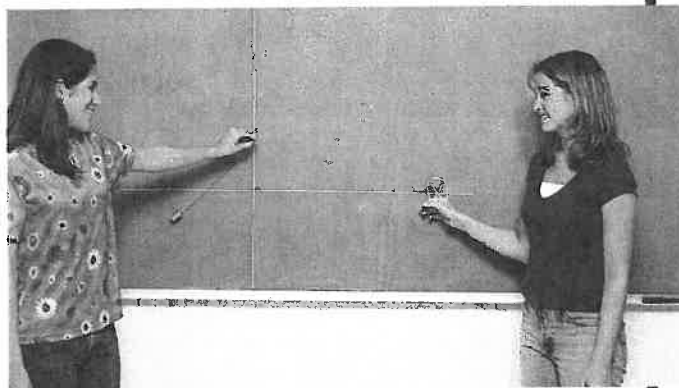

6. Try placing the pencil at different heights along the vertical line. How does this affect the motion of the pendulum? If you put the pencil down close enough to the arc of the pendulum, the pendulum will do a loop around it. Why does that happen?

Analysis

1. Use the law of conservation of energy to explain your observations in steps 2–6.
2. If you let the pendulum swing long enough, it will start to slow down, and it won't rise to the line any more. That suggests that the system has lost energy. Has it? Where did the energy go?

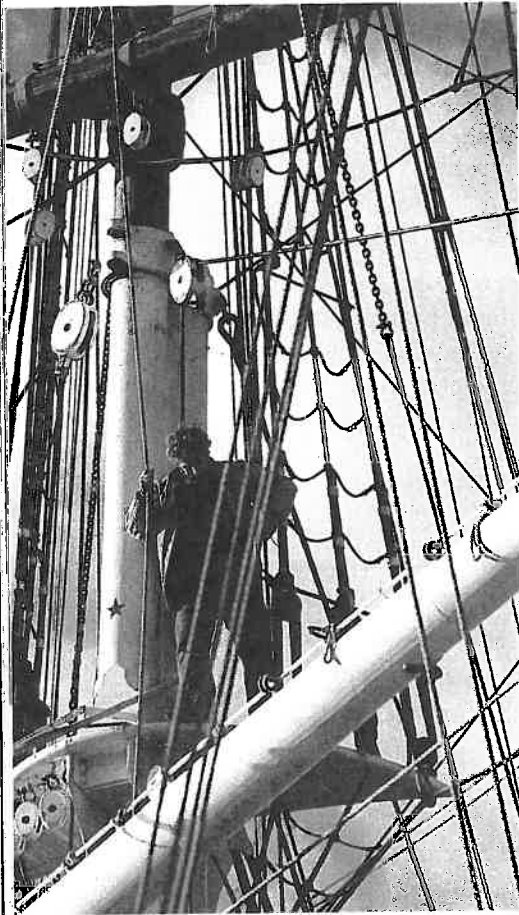

Figure 23

Like all machines, the pulleys on a sailboat are less than 100 percent efficient.

Efficiency of Machines

If you use a pulley to raise a sail on a sailboat like the one in **Figure 23**, you have to do work against the forces of friction in the pulley. You also have to lift the added weight of the rope and the hook attached to the sail. As a result, only some of the energy that you transfer to the pulley is available to raise the sail.

Not all of the work done by a machine is useful work

Because of friction and other factors, only some of the work done by a machine is applied to the task at hand; the machine also does some incidental work that does not serve any intended purpose. In other words, there is a difference between the total work done by a machine and the *useful* work done by the machine, that is, work that the machine is designed or intended to do.

Although all of the work done on a machine has some effect on the output work that the machine does, the output work might not be in the form that you expect. In lifting a sail, for example, some of the work available to lift the sail, which would be useful work, is transferred away as heat that warms the pulley because of friction. This warming is not a desired effect. The amount of useful work might decrease slightly more if the pulley squeaks, because some energy is “lost” as it dissipates into forces that vibrate the pulley and the air to produce the squeaking sound.

Efficiency is the ratio of useful work out to work in

The **efficiency** of a machine is a measure of how much useful work it can do. Efficiency is defined as the ratio of useful work output to total work input.

Efficiency Equation

$$\text{efficiency} = \frac{\text{useful work output}}{\text{work input}}$$

■ **efficiency** a quantity, usually expressed as a percentage, that measures the ratio of useful work output to work input

Efficiency is usually expressed as a percentage. To change an answer found using the efficiency equation into a percentage, just multiply the answer by 100 and add the percent sign, “%.”

A machine with 100 percent efficiency would produce exactly as much useful work as the work done on the machine. Because every machine has some friction, no machine has 100 percent efficiency. The useful work output of a machine never equals—and certainly cannot exceed—the work input.

Perpetual motion machines are impossible

Figure 24 shows a machine designed to keep on going forever without any input of energy. These theoretical machines are called *perpetual motion machines*. Many clever inventors have devoted a lot of time and effort to designing such machines. If such a perpetual motion machine could exist, it would require a complete absence of friction and air resistance.

Math Skills

Efficiency A sailor uses a rope and an old, squeaky pulley to raise a sail that weighs 140 N. He finds that he must do 180 J of work on the rope in order to raise the sail by 1 m (doing 140 J of work on the sail). What is the efficiency of the pulley? Express your answer as a percentage.

1 List the given and unknown values.

Given: $work\ input = 180\ J$
 $useful\ work\ output = 140\ J$

Unknown: $efficiency = ?\ %$

2 Write the equation for efficiency.

$$efficiency = \frac{useful\ work\ output}{work\ input}$$

3 Insert the known values into the equation, and solve.

$$efficiency = \frac{140\ J}{180\ J} = 0.78$$

To express this as a percentage, multiply by 100 and add the percent sign, “%.”

$$efficiency = 0.78 \times 100 = 78\%$$

Practice

Efficiency

1. Alice and Jim calculate that they must do 1800 J of work to push a piano up a ramp. However, because they must also overcome friction, they actually must do 2400 J of work. What is the efficiency of the ramp?
2. It takes 1200 J of work to lift the car high enough to change a tire. How much work must be done by the person operating the jack if the jack is 25 percent efficient?
3. A windmill has an efficiency of 37.5 percent. If a gust of wind does 125 J of work on the blades of the windmill, how much output work can the windmill do as a result of the gust?

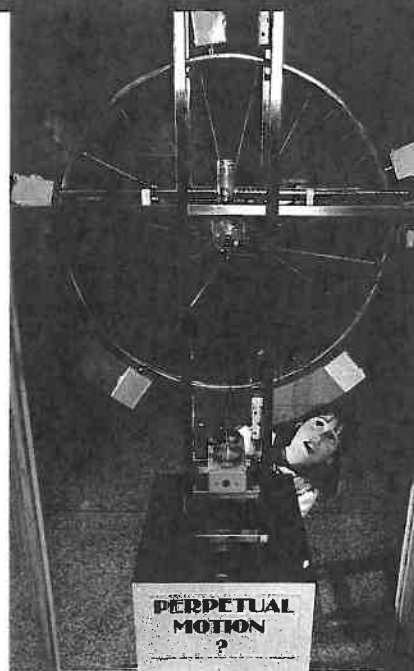

Figure 24 Theoretically, a perpetual motion machine could keep going forever without any energy loss or energy input.

Practice HINT

- ▶ The efficiency equation can be rearranged to isolate any of the variables on the left
- ▶ For practice problem 2, you will need to rearrange the equation to isolate work input on the left side.
- ▶ For practice problem 3, you will need to rearrange to isolate useful work output.
- ▶ When using these rearranged forms to solve the problems, you will have to plug in values for efficiency. When doing so, do not use a percentage, but rather convert the percentage to a decimal by dropping the percent sign and dividing by 100.

Machines need energy input

Because energy always leaks out of a system, every machine needs at least a small amount of energy input to keep going. Unfortunately, that means that perpetual motion machines are impossible. But new technologies, from magnetic trains to high speed microprocessors, reduce the amount of energy leaking from systems so that energy can be used as efficiently as possible.

SECTION 4 REVIEW

SUMMARY

- ▶ Energy readily changes from one form to another.
- ▶ In a mechanical system, potential energy can become kinetic energy, and kinetic energy can become potential energy.
- ▶ Mechanical energy can change to nonmechanical energy as a result of friction, air resistance, or other means.
- ▶ Energy cannot be created or destroyed, although it may change form. This is called the law of conservation of energy.
- ▶ A machine cannot do more work than the work required to operate the machine. Because of friction, the work output of a machine is always somewhat less than the work input.
- ▶ The efficiency of a machine is the ratio of the useful work performed by the machine to the work required to operate the machine.

1. **List** three situations in which potential energy becomes kinetic energy and three situations in which kinetic energy becomes potential energy.
2. **State** the law of conservation of energy in your own words. Give an example of a situation in which the law of conservation of energy is demonstrated.
3. **Describe** the rise and fall of a basketball using the concepts of kinetic energy and potential energy.
4. **Explain** why machines are not 100 percent efficient.
5. **Applying Knowledge** Use the concepts of kinetic energy and potential energy to describe the motion of a child on a swing. Why does the child need a push from time to time?
6. **Creative Thinking** Using what you have learned about energy transformations, explain why the driver of a car has to continuously apply pressure to the gas pedal in order to keep the car cruising at a steady speed, even on a flat road. Does this situation violate the law of conservation of energy? Explain.

Math Skills

7. **Efficiency** When you do 100 J of work on the handle of a bicycle pump, it does 40 J of work pushing the air into the tire. What is the efficiency of the pump?
8. **Efficiency and Power** A river does 6500 J of work on a water wheel every second. The wheel's efficiency is 12 percent.
 - a. How much work in joules can the axle of the wheel do in a second?
 - b. What is the power output of the wheel?
9. **Efficiency and Work** John is using a pulley to lift the sail on his sailboat. The sail weighs 150 N and he must lift it 4.0 m.
 - a. How much work must be done on the sail?
 - b. If the pulley is 50 percent efficient, how much work must John do on the rope in order to lift the sail?

Graphing Skills

Total Mechanical Energy of a Bouncing Ball

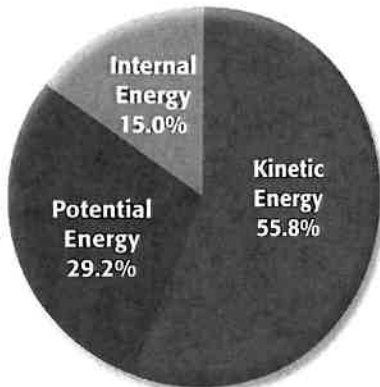

$t = 0.75 \text{ s}$

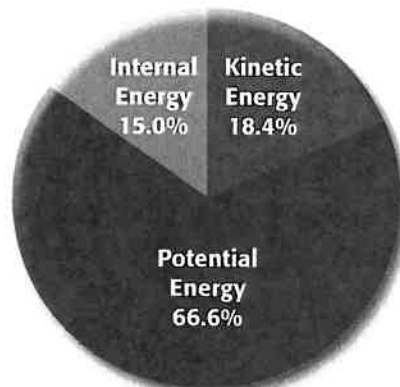

$t = 1.5 \text{ s}$

Examine the graphs above and answer the following questions.

- 1** What type of graphs are these?
- 2** Identify the information provided by each graph.
- 3** Does the total mechanical energy change between 0.75 s and 1.5 s? What does change in this time interval?
- 4** Assume that the internal energy of the ball increases only when it bounces off the floor. What can you tell about the number of times the ball has bounced between 0.75 s and 1.5 s?
- 5** In which graph is the ball moving fastest? In which is the ball higher above the ground? Explain your answers.
- 6** Suppose you are asked to design a ball that bounces to nearly the same height as that from which it is dropped. In terms of energy, what property would this ball require?
- 7** Construct the type of graph best suited for the data given in the table below. Is mechanical energy conserved in this process? Explain your answer.

| Time (s) | Potential energy (J) | Kinetic energy (J) | Internal energy (J) |
|----------|----------------------|--------------------|---------------------|
| 0 | 30.0 | 0 | 0 |
| 0.50 | 15.0 | 12.0 | 3.0 |
| 1.00 | 5.0 | 20.0 | 5.0 |
| 1.50 | 0 | 24.0 | 6.0 |

Chapter Highlights

Before you begin, review the summaries of the key ideas of each section, found at the end of each section. The key vocabulary terms are listed on the first page of each section.

UNDERSTANDING CONCEPTS

- _____ is defined as force acting over a distance.
 - Power
 - Energy
 - Work
 - Potential energy
- The quantity that measures how much a machine multiplies force is called
 - mechanical advantage.
 - leverage.
 - efficiency.
 - power.
- Scissors are an example of
 - a lever.
 - a wedge.
 - a wheel and axle.
 - a compound machine.
- The unit that represents 1 J of work done each second is the
 - power.
 - newton.
 - watt.
 - mechanical advantage.
- Units of joules could be used when measuring
 - the work done in lifting a bowling ball.
 - the potential energy of a bowling ball held in the air.
 - the kinetic energy of a rolling bowling ball.
 - All of the above
- Which of the following situations does *not* involve potential energy being changed into kinetic energy?
 - an apple falling from a tree
 - shooting a dart from a spring-loaded gun
 - pulling back on the string of a bow
 - a creek flowing downstream
- _____ is determined by both mass and velocity.
 - Work
 - Power
 - Potential energy
 - Kinetic energy
- Energy that does not involve the large-scale motion or position of objects in a system is called
 - potential energy.
 - mechanical energy.
 - nonmechanical energy.
 - conserved energy.
- The law of conservation of energy states that
 - the energy of a system is always decreasing.
 - no machine is 100 percent efficient.
 - energy is neither created nor destroyed.
 - Earth has limited energy resources.
- Power is measured in
 - watts.
 - joules.
 - newtons.
 - kilograms.
- Which of the following can a machine not do?
 - change the direction of a force
 - multiply or increase a force
 - redistribute work
 - increase the total amount of work done
- A machine with a mechanical advantage of less than one
 - increases speed and distance.
 - multiplies force.
 - increases output force.
 - reduces distance and speed.
- A perpetual motion machine is impossible because
 - machines require energy input.
 - machines do not require energy input.
 - machines have become too efficient.
 - friction is negligible.

USING VOCABULARY

14. Write one sentence using *work* in the scientific sense, and write another sentence using it in a different, nonscientific sense. Explain the difference in the meaning of *work* in the two sentences.

WRITING SKILL

15. The first page of this chapter shows an example of *kinetic sculpture*. You have now also learned the definition of *kinetic energy*. Given your knowledge of these two terms, what do you think the word *kinetic* means?

16. A can opener is a *compound machine*. Name three *simple machines* that it contains.

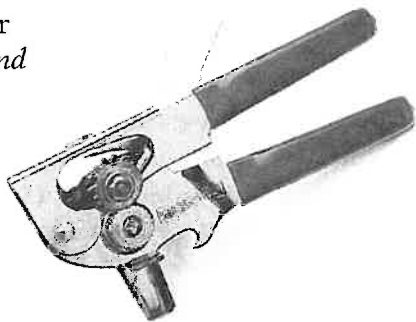

17. For each of the following, state whether the system contains primarily *kinetic energy* or *potential energy*:
- a stone in a stretched slingshot
 - a speeding race car
 - water above a hydroelectric dam
 - the water molecules in a pot of boiling water
18. An elephant and a mouse race up the stairs. The mouse beats the elephant by a full second, but the elephant claims, "I am more powerful than you are, and this race has proved it." Use the definitions of *work* and *power* to support the elephant's claim.
19. How is *energy* related to *work*, *force*, and *power*?
20. List several examples of how *electrical energy* and *light energy* are useful to you.

BUILDING MATH SKILLS

21. You and two friends apply a force of 425 N to push a piano up a 2.0 m long ramp.
- Work** How much work in joules has been done when you reach the top of the ramp?
 - Power** If you make it to the top in 5.0 s, what is your power output in watts?
 - Mechanical Advantage** If lifting the piano straight up would require 1700 N of force, what is the mechanical advantage of the ramp?
22. A crane uses a block and tackle to lift a 2200 N flagstone to a height of 25 m.
- Work** How much work is done on the flagstone?
 - Efficiency** In the process, the crane's hydraulic motor does 110 kJ of work on the cable in the block and tackle. What is the efficiency of the block and tackle?
 - Potential Energy** What is the potential energy of the flagstone when it is 25 m above the ground?
23. A 2.0 kg rock sits on the edge of a cliff 12 m above the beach.
- Potential Energy** Calculate the potential energy in the system.
 - Energy Transformations** The rock falls off the cliff. How much kinetic energy will it have just before it hits the beach? (Ignore air resistance.)
 - Kinetic Energy** Calculate the speed of the rock just before it hits the beach. (For help, see Practice Hint on page 301.)
 - Conservation of Energy** What happens to the energy after the rock hits the beach?

THINKING CRITICALLY

24. Interpreting Graphics The diagram below shows five different points on a roller coaster.

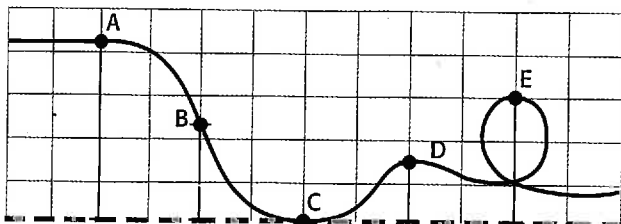

- List the points in order from the point where the car would have the greatest potential energy to the point where it would have the least potential energy.
 - Now list the points in order from the point where the car would have the greatest kinetic energy to the point where it would have the least kinetic energy.
 - How are your two lists related to each other?
- 25. Critical Thinking** Use the law of conservation of energy to explain why the work output of a machine can never exceed the work input.
- 26. Applying Knowledge** If a bumper car triples its speed, how much more work can it do on a bumper car at rest? (**Hint:** Use the equation for kinetic energy.)
- 27. Understanding Systems** When a hammer hits a nail, there is a transfer of energy as the hammer does work on the nail. However, the kinetic energy and potential energy of the nail do not change very much. What happens to the work done by the hammer? Does this violate the law of conservation of energy?
- 28. Critical Thinking** You are attempting to move a large rock using a long lever. Will the work you do on the lever be greater than, the same as, or less than the work done by the lever on the rock? Explain your answer.
- 29. Applying Knowledge** If a machine cannot multiply the amount of work, then what is the advantage of using a machine?
- 30. Applying Knowledge** You are designing a roller coaster in which a car will be pulled to the top of a hill and then will be released to roll freely down the hill toward the top of the next hill. The next hill is twice as high. Will your design be successful?
- 31. Applying Knowledge** In two or three sentences, explain the force-distance trade-off that occurs when a machine is used to make work easier. Use the lever as an example of one type of trade-off.
- 32. Applying Knowledge** Why do you think that levers have a greater mechanical efficiency than other simple machines do?

DEVELOPING LIFE/WORK SKILLS

- 33. Applying Knowledge** You are trying to pry the lid off a paint can with a screwdriver, but the lid will not budge. Should you try using a shorter screwdriver or a longer screwdriver? Explain.
- 34. Designing Systems** Imagine you are trying to move a piano into a second-floor apartment. It will not fit through the stairwell, but it will fit through a large window 3.0 m off the ground. The piano weighs 1740 N and you can exert only 290 N of force. Design a system of machines you could use to lift the piano to the window.
- 35. Teaching Others** Prepare a poster or a series of models of common machines that explains their uses and how they work. Include a diagram next to each sample labeling parts of each machine. Add your own examples of simple machines to the following list: nail clipper, wheelbarrow, can opener, nutcracker, electric drill, screwdriver, tweezers, and a key in a lock.

36. Designing Systems Many mountain roads are built so that they zigzag up a mountain rather than go straight up toward the peak. Discuss the advantage of such a design from the viewpoint of energy conservation and power. Think of a winding road as a series of inclined planes.

37. Applying Knowledge Explain why you do work on a bag of groceries when you pick it up, but not when you are carrying it.

INTEGRATING CONCEPTS

38. Connection to Sports A baseball pitcher applies a force to the ball as his arm moves a distance of 1.0 m. Using a radar gun, the coach finds that the ball has a speed of 18 m/s after it is released. A baseball has a mass of 0.15 kg. Calculate the average force that the pitcher applied to the ball. (Hint: You will need to use both the kinetic energy equation and the work equation.)

39. Concept Mapping Copy the unfinished concept map below onto a sheet of paper. Complete the map by writing the correct word or phrase in the lettered boxes.

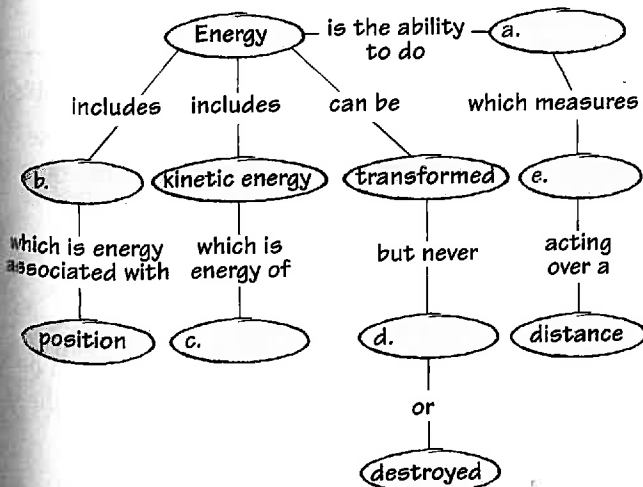

40. Connection to Earth Science Many fuels come from fossilized plant and animal matter. How is the energy stored in these fuels? How do you think that energy got into the fuels in the first place?

41. Connection to Biology When lifting an object using the biceps muscle, the forearm acts as a lever with the fulcrum at the elbow. The input work is provided by the biceps muscle pulling up on the bone. Assume that the muscle is attached 1.0 cm from the elbow and that the total length of the forearm from elbow to palm is 32 cm. How much force must the biceps exert to lift an object weighing 12 N? What class of lever is the forearm in this example?

internet connect

www.scilinks.org

Topic: Energy and Sports SciLinks code: HK4047

SCILINKS Maintained by the National Science Teachers Association

Art Credits: Figs. 6, 7, 8A, 8B, 13, Stephen Durke/Washington Artists; Fig. 22, Uhl Studios, Inc.

Photo Credits: Chapter Opener photo of George Rhodes' auto-kinetic sculpture by Wayne Source; portrait of Alexander Calder by Tony Vaccaro/AGK Photo, London; Fig. 1, Amwell/Getty Images/Stone; Inquiry Lab, Sam Dudgeon/HRW; Figs. 2-3, Peter Van Steen/HRW; Fig. 4 (hammer), Michelle Bridwell/HRW; (pulley), Visuals Unlimited/A. J. Copley; (wheel), Peter Van Steen/HRW; (ramp), Sam Dudgeon/HRW; (wedge), Superstock; (drill bit), Dr. E. R. Degginger/Color-Pic, Inc.; Fig. 5 (hammer) Michelle Bridwell/HRW; (wheelbarrow), John P. Kelly/Getty Images/The Image Bank; (arm), Sam Dudgeon/HRW; Fig. 7, Peter Van Steen/HRW, Fig. 8 (ramp), Sam Dudgeon/HRW; (wedge), Superstock; (drill bit), Dr. E. R. Degginger/Color-Pic, Inc.; "Connection to Social Studies," M. O'Neill/Getty Images/The Image Bank; Figs. 9-10, Peter Van Steen/HRW; Fig. 11, Picture Perfect; Fig. 12, Kindra Clineff/The Picture Cube/Index Stock; Fig. 13, Randy Ury/Corbis Stock Market; Fig. 14, Al Francekevich/Corbis Stock Market; "Real World Applications," Peter Van Steen/HRW; Fig. 15, NASA/Phototake; Fig. 16, Steve Bloom/Picture Perfect; Fig. 17, E. R. Degginger/Color-Pic, Inc.; Fig. 18, AFP/CORBIS; Fig. 20, Getty Images/FPG International; Fig. 21, Henry Groskinsky/Peter Arnold, Inc.; "Inquiry Lab," Sam Dudgeon/HRW; Fig. 23, Visuals Unlimited/Albert J. Copley; Fig. 37, Hank Morgan/Rainbow Inc.; "Chapter Review," (can opener), Peter Van Steen/HRW; "Skill Builder Lab," Peter Van Steen/HRW; "Career Link," Ken Kinzie/Latent Image Photography/HRW.

Skills Practice Lab

Introduction

Raised objects have gravitational potential energy. Moving objects have kinetic energy. How are these two quantities related in a system that involves a ball rolling down a ramp?

Objectives

- ▶ **Measure** the height, distance traveled, and time interval for a ball rolling down a ramp.
- ▶ **Calculate** the ball's potential energy at the top of the ramp and its kinetic energy at the bottom of the ramp.
- ▶ **USING SCIENTIFIC METHODS Analyze the results** to find the relationship between potential energy and kinetic energy.

Materials

balance
 board, at least 90 cm (3 ft) long
 box
 golf ball, racquet ball, or handball
 masking tape
 meterstick
 stack of books, at least 60 cm (2 ft) high
 stopwatch

Determining Energy for a Rolling Ball

▶ Procedure

Preparing for Your Experiment

1. On a blank sheet of paper, prepare a table like the one shown below.

Table 1 Potential Energy and Kinetic Energy

| | Height 1 | Height 2 | Height 3 |
|--------------------------------------|----------|----------|----------|
| Mass of ball (kg) | | | |
| Length of ramp (m) | | | |
| Height of ramp (m) | | | |
| Time ball traveled, first trial (s) | | | |
| Time ball traveled, second trial (s) | | | |
| Time ball traveled, third trial (s) | | | |
| Average time ball traveled (s) | | | |
| Final speed of ball (m/s) | | | |
| Final kinetic energy of ball (J) | | | |
| Initial potential energy of ball (J) | | | |

2. Measure the mass of the ball, and record it in your table.
3. Place a strip of masking tape across the board close to one end, and measure the distance from the tape to the opposite end of the board. Record this distance in the row labeled "Length of ramp."
4. Make a catch box by cutting out one side of a box.
5. Make a stack of books approximately 30 cm high. Build a ramp by setting the taped end of the board on top of the books, as shown in the photograph on the next page. Place the other end in the catch box. Measure the vertical height of the ramp at the tape, and record this value in your table as "Height of ramp."



Making Time Measurements

6. Place the ball on the ramp at the tape. Release the ball, and measure how long it takes the ball to travel to the bottom of the ramp. Record the time in your table.
7. Repeat step 6 two more times and record the results in your table. After three trials, calculate the average travel time and record it in your table.
8. Repeat steps 5–7 with a stack of books approximately 45 cm high, and repeat the steps again with a stack approximately 60 cm high.

► Analysis

1. Calculate the average speed of the ball using the following equation:

$$\text{average speed} = \frac{\text{length of ramp}}{\text{average time ball traveled}}$$

2. Multiply average speed by 2 to obtain the final speed of the ball, and record the final speed.
3. Calculate and record the final kinetic energy of the ball by using the following equation:

$$KE = \frac{1}{2} \times \text{mass of ball} \times (\text{final speed})^2$$

$$KE = \frac{1}{2}mv^2$$

4. Calculate and record the initial potential energy of the ball by using the following equation:

$$\begin{aligned} \text{grav. PE} &= \text{mass of ball} \times (9.8 \text{ m/s}^2) \times \text{height of ramp} \\ PE &= mgh \end{aligned}$$

► Conclusions

5. For each of the three heights, compare the ball's potential energy at the top of the ramp with its kinetic energy at the bottom of the ramp.
6. How did the ball's potential and kinetic energy change as the height of the ramp was increased?
7. Suppose you perform this experiment and find that your kinetic energy values are always just a little less than your potential energy values. Does that mean you did the experiment wrong? Why or why not?

