

Gloucester County Public Schools



Secondary Program of Studies Grades 6-12

Academic Years

2021-22 and 2022-23

File No. IF-R

Gloucester County Schools Administration

Gloucester County School Board

Robin Rice *Chair, Ware District*
Elisa Nelson *Vice-Chair, York District*
Troy Andersen *Gloucester Point District*
George R. (Randy) Burak *Abingdon District*
Brenda Mack *Member-at-Large*
Anita F. Parker *Petsworth District*
Darren Post *Member-at-Large*

Administrative Members

Walter R. Clemons, Ph.D. *Division Superintendent*
Charles A. Wagner, Ed.D. *Asst. Superintendent for Instruction*
Tanya Deckard *Director, Transportation*
Rachel Blankenship *Executive Director, Human Resources*
Jennifer Tingley, Ed.D. *Director, Specialized Education*
Bryan Hartley *Executive Director, Operations*
Heather Lucas *Chief Financial Officer*
Jim Rieflin *Director, Technology*
Stephen E. Patton *Director, Food Services*
Bess B. Worley II, Ph.D. *Director, Assessment & Evaluation*

Page Middle School Administration

Sharon Hendrix *Principal*
Daryl Oakley *Assistant Principal*

Gloucester County Schools Instructional Services

Julie Bryant *Lead Teacher, English Learner Program*
Paula Dawson *Coordinator, Specialized Education*
Jenna Dominguez *Secondary Language Arts Specialist*
Kristen Heaney *Secondary Math Specialist*
Melanie Jenkins *Elementary Math Specialist*
Michelle Larsen *Teacher, English Learner Program*
Katharine Litton *Academic Support Coordinator & Virtual Learning, Instruction*
Patricia McMahon, Ph.D. *Program Support Coordinator, Specialized Education*
Jennifer McSweeney, Ed.D. *Elementary Literacy Specialist*
Gaye Murphy *Gifted Education Specialist*
Mary Runnells, Ph.D. *Learning Coach, Specialized Education*
Rhonda Taylor *Gifted Education Teacher*

Gloucester High School Administration

Stefan Mygas, Ed.D. *Principal*
Carol L. Belvin *Assistant Principal*
Shantell Brinkley *Assistant Principal*
Alexis Foster *Assistant Principal*
Jodie Simpson *Assistant Principal*
Shannon Auché *Assistant Principal, iMPACT*
Kristy Hunter *Director of Athletics & Activities*
Matthew Lord *Director of School Counseling*

Peasley Middle School Administration

Craig Reed, Ed.D. *Principal*
Cathy Balderson *Assistant Principal*

Message from the Superintendent

As Division Superintendent, I welcome you to another exciting school year. The mission of Gloucester County Public Schools is to provide a safe environment in which all students have a right to learn and will receive assistance in acquiring knowledge and skills to become literate, contributing citizens in a democracy. It is indeed an honor and a privilege to write this note in support of the Program of Studies for students in grades 6-12.

This publication reflects a balanced selection of course offerings for students to consider in grades 6-12 that will prepare them to be successful not only in Gloucester County Public Schools, but also in life after high school. I encourage and challenge all students to take classes that will challenge and prepare you to be successful in today's ever changing society. In addition, I encourage you to explore and make new discoveries as you will be the leaders of tomorrow. It is my sincerest desire to see all students reach their fullest potential. In closing, I wish each of you the best of success and please know that Gloucester County Public Schools is here to support you in carving the paths that will allow you to reach your goals and dreams. Shoot for the moon and you will always be among the stars. Have a great school year!

Sincerely,



Walter R. Clemons, Ph.D.

Greetings from our Secondary Principals

Welcome to Gloucester High School! I am excited to have you as a member of the Dukes family! GHS is a great school with a variety of options for our students to learn and to become prepared for life after high school. In accordance with the Profile of a Virginia Graduate, we are proud to offer rigorous and engaging academic programs designed to help students attain content knowledge, workplace skills, community engagement and civic responsibility, and career exploration.

I strongly encourage you to make the most out of your high school experience. The four years you spend at GHS are an opportunity to develop new interests and grow personally and academically. I also recommend you to choose courses which allow you to balance academic expectations with additional opportunities through our many clubs, activities, and athletic teams.

The GHS faculty and staff are passionate about preparing our students for whatever pathway they choose. We encourage all students and parents to maintain a positive, open line of communication between home and school and to let us know if you have any questions, comments, concerns, or suggestions to make our school the best it can be. GO DUKES!



Stefan Mygas, Ed.D.
Principal, Gloucester High School

Welcome to Page Middle School! As a member of the Page family, students are supported and guided by a professional and caring team to be successful in an ever-changing world. Through strong relationships and communication between faculty, staff, parents, students, and community members, this common goal is at the forefront of all interactions. Students at Page will learn in an environment that is nurturing, challenging, and full of experiences to prepare them for the next level of education.

This is a unique age where students transition from children to teenagers, and many things will change for students during this period of time. To help with these adjustments, we are pleased to have this Program of Studies for families and students to use as a guide as educational plans are mapped out for middle and high school. Our educational experts have worked diligently to prepare paths for our students to lead them to a successful foundation and prepare them for the journey into high school and beyond.

Along the way, students will have the opportunity to explore interests through exploratory arts, clubs, and athletics. Each student is encouraged to be active in their own education and find the passions that bring them happiness and a sense of accomplishment. Our school counselors are available to assist if there are any questions along the way. Please feel free to contact me or anyone in our educational organization as we are all eager to provide students, families, and our community with a middle school experience that is ideal for every student.



Sharon B. Hendrix
Principal, Page Middle School

Welcome to Peasley Middle School! On behalf of Peasley Middle School, we are excited about the partnership between our students, parents, faculty and staff. We know that this partnership will be a critical component in ensuring success for all of our learners this year. As such, we welcome your involvement and collaboration as we work to ensure that all of our learners are successful.

We hope that this program of studies can serve as a resource for planning your child's learning at Peasley Middle School and beyond. Our school offers a number of learning opportunities that will challenge and engage our learners. To add, we strive to provide learning experiences that will give our students the foundation and skills that they will need to meet the challenges of the 21st century.

We encourage you to contact our school to identify a pathway of learning to meet the needs of your student. We are confident that this program of studies will provide a vast array of learning opportunities that will be engaging and rigorous. We also encourage you to maintain contact with our teachers and counselors.

Please feel free to contact me or any member of the Peasley staff to further build a partnership that we know will serve all of our students.



Craig Reed, Ed.D.
Principal, Peasley Middle School

Contact Information

Gloucester County School Board

6099 T.C. Walker Road
Gloucester, VA 23061
(804) 693-5300
<http://gets.gc.k12.va.us>

Gloucester High School

6680 Short Lane
Gloucester, VA 23061
(804) 693-2526
<http://ghs.gc.k12.va.us>

Page Middle School

5198 T.C. Walker Road
Gloucester, VA 23061
(804) 693-2540
<http://pagems.gloucester.schooldesk.net>

Peasley Middle School

2885 Hickory Fork Road
Gloucester, VA 23061
(804) 693-1499
<http://pms.gloucester.schooldesk.net/>

No student can be prevented from participation in any program solely because of his/her race, color, national origin, gender, age, religion, disability, or sexual orientation. A procedure for resolving complaints alleging discrimination on the basis of race, color, national origin, gender, age, religion, or disability may be found in the manual for Policies and Regulations of the Gloucester County Public Schools.

The Section 504, Local Homeless Liaison and Title IX Coordinator for the Gloucester County Public Schools is:

Mr. Bryan Hartley, Coordinator, Section 504, Local Homeless Liaison and Title IX
Gloucester County Public Schools
6099 T.C. Walker Road, Gloucester, VA 23061
(804) 693-7856

Table of Contents

Graduation Requirements Classes of 2015 and beyond	6-9
Virginia Board of Education Diploma Seals	10
Academic and Career Plans	11
Progress Towards On-Time Graduation	11
GCPS English, Social Studies, Mathematics, and Science Pathways	12-14
Gloucester County Public Schools Grades 6-8 Curriculum <ul style="list-style-type: none"> • Core Academics <ul style="list-style-type: none"> Language Arts Mathematics Science History and Social Sciences • Career & Technical Education • Visual and Performing Arts • World Language • Health and Physical Education 	15-20
GHS Scheduling Policies and Procedures	21-22
Gloucester County Public Schools Grades 9-12 Curriculum <ul style="list-style-type: none"> • Career & Technical Ed (including NJROTC) <ul style="list-style-type: none"> Industry Certifications and Licenses • English • Fine Arts • Foreign Language • Health, Physical Education and Driver's Education • History and Social Sciences • Mathematics • Science • Specialized Educational Services 	22-59
Early College Scholars Program	60
Dual Enrollment Courses at Rappahannock Community College	60-61
Concurrent College Enrollment	62
Advanced Placement Courses	62
Virtual Virginia Advanced Placement Courses	63
Virtual Learning Programs	63
Chesapeake Bay Governor's School	64-66
New Horizons Governor's School For Science & Technology	67-71
New Horizons Career & Technical Education Center	72-77
Greater Peninsula Governor's STEM Academy (GPGSA)	78
Governor's Health Sciences Academy (GHSa)	78-79
Gloucester High School STEM Academy and Course Pathways	80-82
Pathways to One Year Certificate of General Studies or Associates Degree	82

Graduation Requirements

Students Entering Grade 9 For First Time in 2018-19

	Standard Diploma	
Discipline Area	Standard Units of Credit	Verified Units of Credit
English (Reading & Writing)	4	2
Mathematics	3	1
Laboratory Science	3	1
History & Social Science	3	1
World Language, Fine Arts, or Career & Technical Education	2	
Economics & Personal Finance	1	
Health & PE	2	
Electives	4	
Total	22	5
Specifications		
Mathematics	Courses completed to satisfy this requirement shall include at least two different course selections from among: Algebra I, Geometry, Algebra Functions and Data Analysis, Algebra II, or other mathematics courses approved by the board to satisfy this requirement. An approved computer science course credit earned by students may be considered a mathematics course credit.	
Laboratory Science	Courses completed to satisfy this requirement shall include course selection from at least two different science disciplines: earth sciences, biology, chemistry, or physics. An approved computer science course credit earned by students may be considered a science course credit.	
History & Social Science	Courses completed to satisfy this requirement shall include Virginia and U.S. History, Virginia and U.S. Government, and one course in either world history or geography or both.	
Laboratory Science, and History and Social Science	Students who complete a career and technical education program sequence and pass an examination or occupational competency assessment in a career and technical education field that confers certification or an occupational competency credential from a recognized industry, trade, or professional association, or acquires a professional license in a career and technical education field from the Commonwealth of Virginia may substitute the certification, competency credential, or license for either a laboratory science or history and social science verified credit when the certification, license, or credential confers more than one verified credit. The examination or occupational competency assessment must be approved by the board as an additional test to verify student achievement.	
World Language, Fine Arts or Career and Technical Education	Credits earned for this requirement shall include one credit in fine or performing arts or career and technical education. A computer science course credit earned by students may be considered a career and technical course credit.	
Electives	Courses completed to satisfy this requirement shall include at least two sequential electives as required by the Standards of Quality.	
Advanced Placement Course, Honors Course, or Career and Technical Education Credential	Students shall either (i) complete an Advanced Placement or Honors course, or (ii) earn a career and technical education credential approved by the board, except when a career and technical education credential in a particular subject area is not readily available or appropriate or does not adequately measure student competency, in which case the student shall receive satisfactory competency-based instruction in the subject area to satisfy the standard diploma requirements. The career and technical education credential, when required, could include the successful completion of an industry certification, a state licensure examination, a national occupational competency assessment, or the Virginia workplace readiness assessment.	
Virtual Course	Students shall successfully complete one virtual course, which may be a non-credit-bearing course or a required or elective credit-bearing course offered online.	
Training in emergency first aid, cardiopulmonary resuscitation (CPR), and the use of automated external defibrillators (AED)	Students shall be trained in emergency first aid, CPR, and the use of AED, including hands-on practice of the skills necessary to perform cardiopulmonary resuscitation. Students with an IEP or 504 Plan that documents that they cannot successfully complete this training shall be granted a waiver from this graduation requirement, as provided in 8VAC20-131- 420 B.	
Demonstration of the five Cs	Students shall acquire and demonstrate foundational skills in critical thinking, creative thinking, collaboration, communication, and citizenship in accordance with the Profile of a Virginia Graduate approved by the board.	

	Advanced Diploma	
Discipline Area	Standard Units of Credit	Verified Units of Credit
English (Reading & Writing)	4	2
Mathematics	4	1
Laboratory Science	4	1
History & Social Science	4	1
World Language	3	
Fine Arts, or Career & Technical Education	1	
Economics & Personal Finance	1	
Health & PE	2	
Electives	3	
Total	26	5
Specifications		
Mathematics	Courses completed to satisfy this requirement shall include at least three different course selections from among: Algebra I, Geometry, Algebra II, or other mathematics courses approved by the board to satisfy this requirement. An approved computer science course credit earned by students may be considered a mathematics course credit.	
Laboratory Science	Courses completed to satisfy this requirement shall include course selection from at least three different science disciplines: earth sciences, biology, chemistry, or physics. An approved computer science course credit earned by students may be considered a science course credit.	
History & Social Science	Courses completed to satisfy this requirement shall include Virginia and U.S. History, Virginia and U.S. Government, and two courses in either world history or geography or both.	
World Language	Courses completed to satisfy this requirement shall include at least three years of one language or at least two years of two languages.	
Fine Arts or Career and Technical Education	A computer science course credit may be considered a career and technical credit.	
Electives	Courses to satisfy this requirement shall include at least two sequential electives as required by the Standards of Quality.	
Advanced Placement Course, Honors Course, or Career and Technical Education Credential	Students shall either (i) complete an Advanced Placement or Honors course, or (ii) earn a career and technical education credential approved by the board, except when a career and technical education credential in a particular subject area is not readily available or appropriate or does not adequately measure student competency, in which case the student shall receive satisfactory competency-based instruction in the subject area to satisfy the advanced diploma requirements. The career and technical education credential, when required, could include the successful completion of an industry certification, a state licensure examination, a national occupational competency assessment, or the Virginia workplace readiness assessment.	
Virtual Course	Students shall successfully complete one virtual course, which may be a non-credit-bearing course or a required or elective credit-bearing course offered online.	
Training in emergency first aid, cardiopulmonary resuscitation (CPR), and the use of automated external defibrillators (AED)	Students shall be trained in emergency first aid, CPR, and the use of AED, including hands-on practice of the skills necessary to perform cardiopulmonary resuscitation. Students with an IEP or 504 Plan that documents that they cannot successfully complete this training shall be granted a waiver from this graduation requirement, as provided in 8VAC20-131- 420 B.	
Demonstration of the five Cs	Students shall acquire and demonstrate foundational skills in critical thinking, creative thinking, collaboration, communication, and citizenship in accordance with the Profile of a Virginia Graduate approved by the board.	

Graduation Requirements

Students Entering Grade 9 For First Time in 2013-14 through 2017-18

Discipline Area	Standard Diploma	
	Standard Units of Credit	Verified Units of Credit
English (Reading & Writing)	4	2
Mathematics ¹	3	1
Laboratory Science ^{2,6}	3	1
History & Social Science ^{3,6}	3	1
World Language, Fine Arts, or Career & Technical Education ⁷	2	
Economics & Personal Finance	1	
Health & PE	2	
Electives ⁴	4	
Student Selected Test ⁵		1
Total	22	6
<p>¹ Courses completed to satisfy this requirement shall include at least two different course selections from among: Algebra I, Geometry, Algebra Functions and Data Analysis, Algebra II, or other mathematics courses above the level of Algebra II. approved by the board to satisfy this requirement. An approved computer science course credit earned by students may be considered a mathematics course credit.</p> <p>² Courses completed to satisfy this requirement shall include course selection from at least two different science disciplines: earth sciences, biology, chemistry, or physics. An approved computer science course credit earned by students may be considered a science course credit.</p> <p>³ Courses completed to satisfy this requirement shall include Virginia and U.S. History, Virginia and U.S. Government, and one course in either world history or geography or both.</p> <p>⁴ Courses completed to satisfy this requirement shall include at least two sequential electives as required by the Standards of Quality.</p> <p>⁵ A student may utilize additional tests for earning verified credit in computer science, technology, career and technical education, economics or other areas as prescribed by the board in 8VAC20-131- 110.</p> <p>⁶ Students who complete a career and technical education program sequence and pass an examination or occupational competency assessment in a career and technical education field that confers certification or an occupational competency credential from a recognized industry, trade, or professional association, or acquires a professional license in a career and technical education field from the Commonwealth of Virginia may substitute the certification, competency credential, or license for either a laboratory science or history and social science verified credit when the certification, license, or credential confers more than one verified credit. The examination or occupational competency assessment must be approved by the board as an additional test to verify student achievement.</p> <p>⁷ Credits earned for this requirement shall include one credit in fine or performing arts or career and technical education. A computer science course credit earned by students may be considered a career and technical education course credit.</p> <p>Other Requirements (1): Students shall earn a career and technical education credential approved by the board, except when a career and technical education credential in a particular subject area is not readily available or appropriate or does not adequately measure student competency, in which case the student shall receive satisfactory competency-based instruction in the subject area to satisfy the standard diploma requirements. The career and technical education credential, when required, could include the successful completion of an industry certification, a state licensure examination, a national occupational competency assessment, or the Virginia workplace readiness assessment. (2) Students shall successfully complete one virtual course, which may be a non-credit-bearing course or a required or elective credit-bearing course offered online. (3) Keyboarding competencies must be met prior to graduation. (4) Beginning with first-time ninth-grade students in the 2016-17 school year, students shall be trained in emergency first aid, CPR, and the use of AED, including hands-on practice of the skills necessary to perform cardiopulmonary resuscitation. Students with an IEP or 504 Plan that documents that they cannot successfully complete this training shall be granted a waiver from this graduation requirement, as provided in 8VAC20-131- 420 B.</p>		

	Advanced Diploma	
Discipline Area	Standard Units of Credit	Verified Units of Credit
English (Reading & Writing)	4	2
Mathematics ¹	4	2
Laboratory Science ²	4	2
History & Social Science ³	4	2
World Language ⁴	3	
Fine Arts or Career & Technical Education ⁵	1	
Economics & Personal Finance	1	
Health & PE	2	
Electives	3	
Student Selected Test ⁶		1
Total	26	9
¹ Courses completed to satisfy this requirement shall include at least three different course selections from among: Algebra I, Geometry, Algebra Functions and Data Analysis, Algebra II, or other mathematics courses above the level of Algebra II, approved by the board to satisfy this requirement. An approved computer science course credit earned by students may be considered a mathematics course credit.		
² Courses completed to satisfy this requirement shall include course selection from at least three different science disciplines: earth sciences, biology, chemistry, or physics. An approved computer science course credit earned by students may be considered a science course credit.		
³ Courses completed to satisfy this requirement shall include Virginia and U.S. History, Virginia and U.S. Government, and two courses in either world history or geography or both.		
⁴ Shall include three years of the same language or two years of two languages.		
⁵ A computer science course credit earned by students may be considered a career and technical education course credit.		
⁶ A student may utilize additional tests for earning verified credit in computer science, technology, career and technical education, economics or other areas as prescribed by the board in 8VAC20-131- 110.		
Other Requirements (1): Students shall earn a career and technical education credential approved by the board, except when a career and technical education credential in a particular subject area is not readily available or appropriate or does not adequately measure student competency, in which case the student shall receive satisfactory competency-based instruction in the subject area to satisfy the standard diploma requirements. The career and technical education credential, when required, could include the successful completion of an industry certification, a state licensure examination, a national occupational competency assessment, or the Virginia workplace readiness assessment. (2) Students shall successfully complete one virtual course, which may be a non-credit-bearing course or a required or elective credit-bearing course offered online. (3) Keyboarding competencies must be met prior to graduation. (4) Beginning with first-time ninth-grade students in the 2016-17 school year, students shall be trained in emergency first aid, CPR, and the use of AED, including hands-on practice of the skills necessary to perform cardiopulmonary resuscitation. Students with an IEP or 504 Plan that documents that they cannot successfully complete this training shall be granted a waiver from this graduation requirement, as provided in 8VAC20-131- 420 B.		

Virginia Board of Education Diploma Seals

Students who demonstrate academic excellence may be eligible for one or more of the following awards. Diploma Seals are attached to the diploma and presented at Commencement.	
The Governor's Seal	<ul style="list-style-type: none"> Advanced Studies Diploma <i>and</i> Average GPA of "B" or better (3.0) <i>and</i> Successfully complete college-level coursework that will earn the student at least nine transferable college credits in Advanced Placement (AP) or dual enrollment courses.
The Board of Education Seal	<ul style="list-style-type: none"> Standard Diploma or Advanced Studies Diploma <i>and</i> Average GPA of "A" or better (4.0)
The Board of Education's Career and Technical Education Seal	<ul style="list-style-type: none"> Standard Diploma or Advanced Studies Diploma <i>and</i> Complete a prescribed sequence of courses in a career and technical education concentration and maintain a "B" average or better in those courses <i>or</i> Pass an examination or an occupational competency assessment in a career and technical education concentration that confers certification or occupational competency credential from a recognized industry <i>or</i> Acquire a professional license in that career and technical education field from the Commonwealth of Virginia.
The Board of Education's Seal for Excellence in Science and the Environment (Available to students who enter Grade 9 for the first time in the 2018-19 SY and beyond)	<ul style="list-style-type: none"> Standard Diploma or Advanced Studies Diploma <i>and</i> Complete at least three different first-level, Board-approved laboratory science courses and at least one rigorous advanced-level or postsecondary-level laboratory science course, each with a grade of "B" or higher, <i>and</i> Complete laboratory or field science research and present the research findings in a formal, juried setting, <i>and</i> Complete at least 50 hours of voluntary participation in community service or extracurricular activities that involve the application of science, such as environmental monitoring, protection management, or restoration.
The Board of Education's Excellence in Civics Education Seal	<ul style="list-style-type: none"> Standard Diploma or Advanced Studies Diploma <i>and</i> Complete US History & US Government course with a "B" average or better (3.0) in those courses <i>and</i> Have good attendance and no disciplinary infractions <i>and</i> Complete 50 hours of voluntary community service or extracurricular activities, to include: <ul style="list-style-type: none"> Charitable or religious organizations that provide services to the poor, sick or less fortunate Boy Scouts/Girl Scouts NJROTC Political campaigns or government internships, Boys or Girls State School sponsored activities with a Civics focus Enlistment in the US Military before graduation
The Board of Education's Seal of Bilingualism	<ul style="list-style-type: none"> Standard Diploma or Advanced Studies Diploma <i>and</i> Pass all required EOC assessments in English Reading and Writing at the proficiency level or higher; <i>and</i> Demonstrate proficiency at the intermediate-mid level or higher in one or more languages other than English (including American Sign Language) through one of a range of approved language assessment options, including Advanced Placement (AP), International Baccalaureate (IB), and other national or international assessments at a level comparable to Intermediate-Mid on the American Council on the Teaching of Foreign Languages (ACTFL) Proficiency Guidelines. The Virginia Department of Education will maintain a list of acceptable national and international tests with qualifying scores for reference in awarding the Seal of Bilingualism.

Other Diplomas & Certificates

Applied Studies Diploma	Available to students with disabilities who complete the requirements of their IEP and meet certain requirements prescribed by the Board of Education pursuant to regulations, but do not meet the requirements for any named diploma.
Certificate of Program Completion	Available to students who complete prescribed programs of studies defined by a local school board but do not meet the requirements of another diploma.
General Education Development Certificate (GED)	Equivalency Certificate obtained through a GED program.

Academic & Career Plans

The Board of Education included in its 2009 revisions to the Regulations Establishing Standards for Accrediting Public Schools in Virginia, (8 VAC-20-131-5 et seq) provisions for each middle and high school student to have a personal learning plan that aligns academic and career goals with the student's course of study.

8 VAC 20-131-140: College and career preparation programs and opportunities for postsecondary credit.

Beginning with the 2012-2013 academic year, all schools shall begin development of a personal Academic and Career Plan for each seventh-grade student with completion by the fall of the student's eighth-grade year. Students who transfer from other than a Virginia public school into the eighth-grade shall have the Plan developed as soon as practicable following enrollment. Beginning with the 2013-2014 academic year, students who transfer into a Virginia public school after their eighth-grade year shall have an Academic and Career Plan developed upon enrollment. The components of the Plan shall include, but not be limited to, the student's program of study for high school graduation and a postsecondary career pathway based on the student's academic and career interests. The Academic and Career Plan shall be developed in accordance with guidelines established by the Board of Education and signed by the student, student's parent or guardian, and school official(s) designated by the principal. The Plan shall be included in the student's record and shall be reviewed and updated, if necessary, before the student enters the ninth and eleventh grades. The school shall have met its obligation for parental involvement if it makes a good faith effort to notify the parent or guardian of the responsibility for the development and approval of the Plan. Any personal academic and career plans prescribed by local school boards for students in grades 7 through 12 and in effect as of June 30, 2009, are approved to continue without further action by the Board.

Progress Toward On-time Graduation

Students are considered to be progressing towards on-time graduation if the following minimum criteria are met:

- Grades 6-9: The instructional administrators (principals, assistant principals, directors, and supervisors of instructional areas) are responsible for maintaining the standards for grade classification at the secondary level. (Policy IKEA)
- Grade 10: Four (4) standard credits to include English 9 and three others. One verified credit.
- Grade 11: Standard credits to include English 9 and 10, one math, one science, one history/social science, and four others. Three verified credits.
- Grade 12 – Fifteen (15) standard credits to include English 9, 10 and 11, two maths, two sciences, two history social sciences to include VA/US History, and six others. At least five (5) verified credits: two in English, one in math, one in science, one in history/social science (and one other for students entering Grade 9 for the first time between 2013-14 and 2017-18).

English/Language Arts Course Pathways

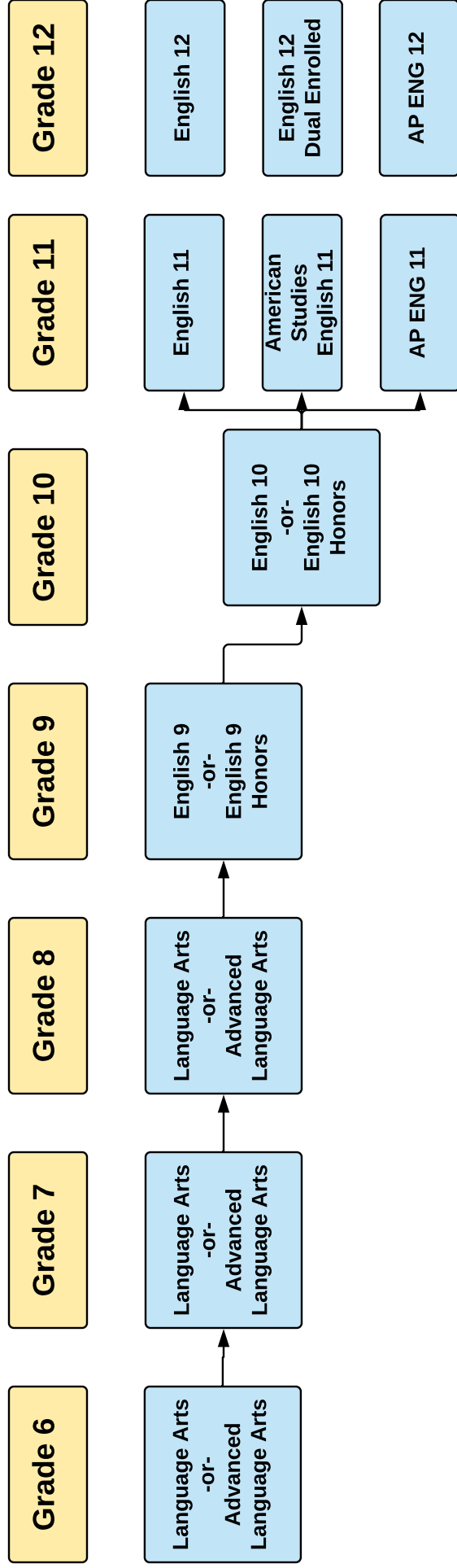

History & Social Science Course Pathways

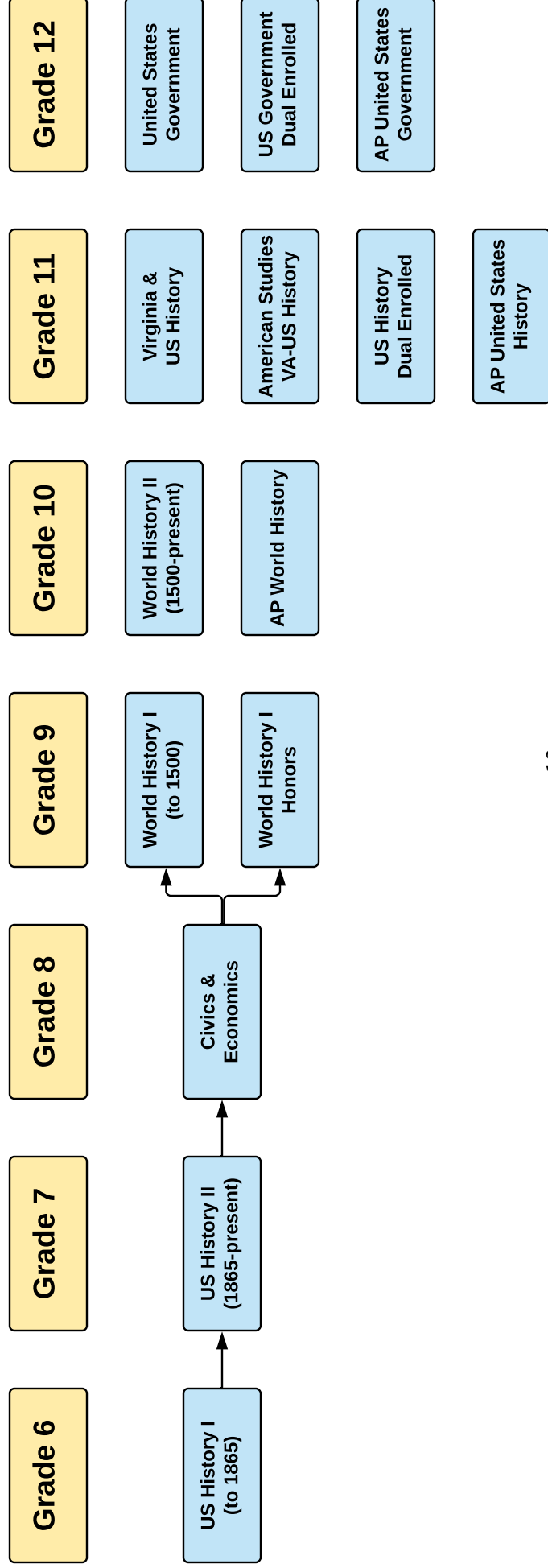

Secondary Science Course Pathways

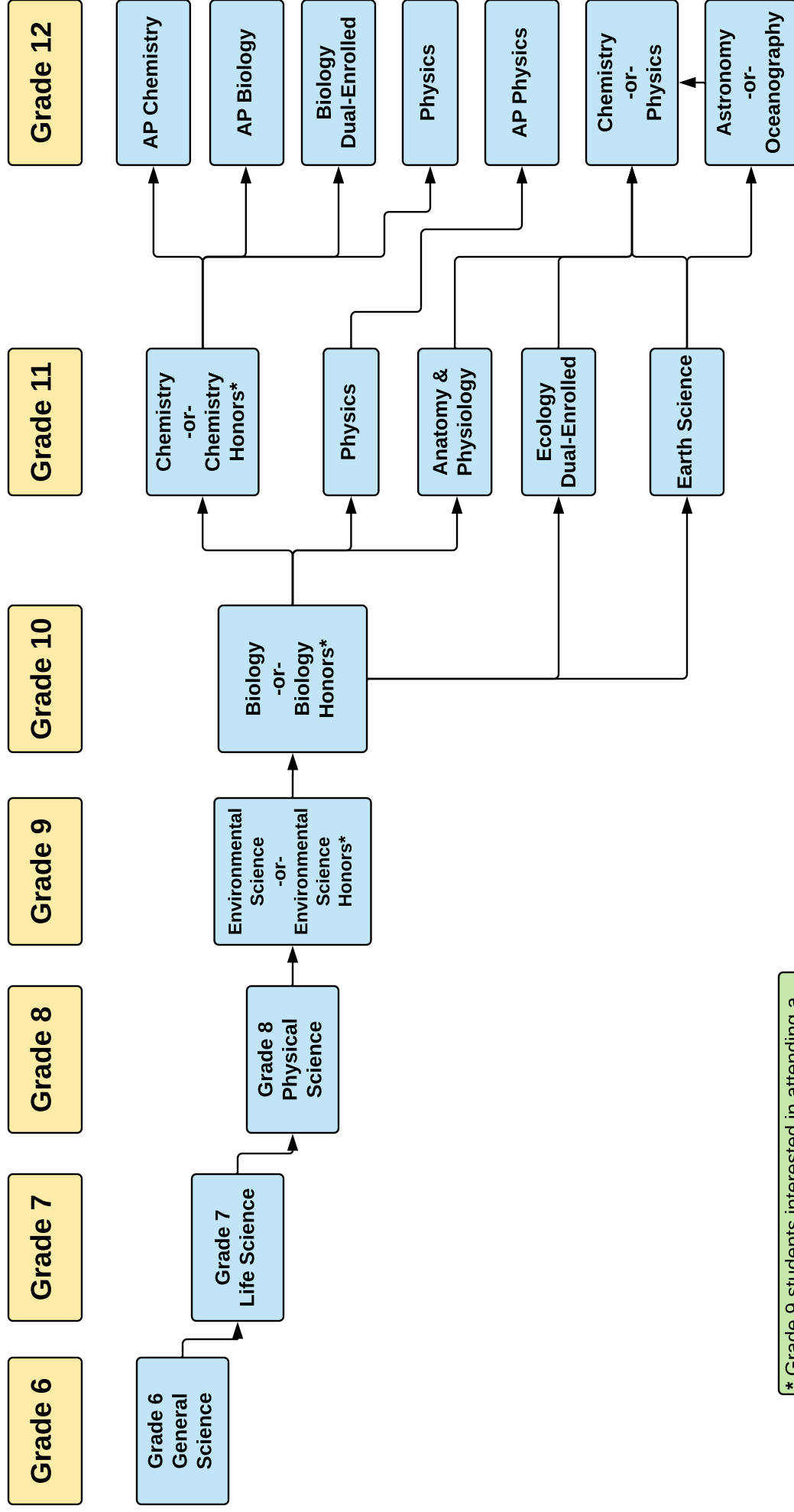

* Grade 9 students interested in attending a Governor's School will take Biology I Honors and Environmental Science Honors as paired courses in the 9th Grade year.

Secondary Math Suggested Course Pathways

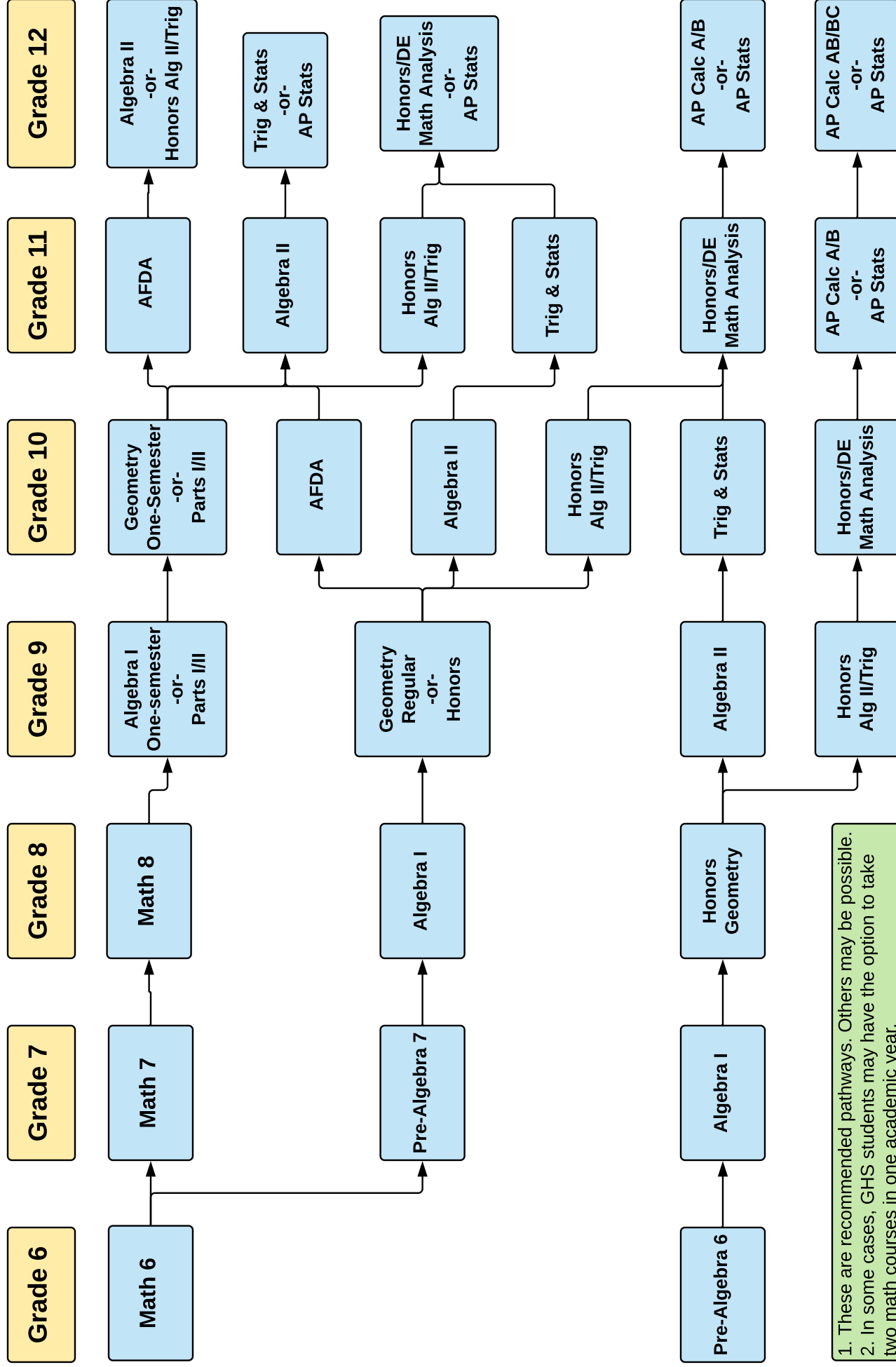

1. These are recommended pathways. Others may be possible.
 2. In some cases, GHS students may have the option to take two math courses in one academic year.
 3. Consult with school counselor for details and questions.

GCPS Grades 6-8 Curriculum

English Language and Literature

51034 Language Arts (Grade 6)

Language Arts (Grade 6) courses build upon students' prior knowledge of grammar, vocabulary, word usage, and the mechanics of writing, and include the four aspects of language use: reading, writing, speaking, and listening. These courses may emphasize the use of language for different effects, in different contexts, and for different purposes. Specific content depends upon state standards for grade 6. Some students may be scheduled for an Intervention period for additional skill development; placement will be based upon prior academic achievement including, but not limited to, fifth grade classroom performance, assessment history, SOLs, reading assessments, screenings, standardized test scores, etc.

510341 Advanced Language Arts (Grade 6)

Advanced Language Arts (Grade 6) emphasizes language skills, grammar, writing, reading strategies, literature, spelling, oral language and research. Students will plan, draft, revise and edit narratives, descriptions and explanations with attention to composition and style, as well as sentence formation, usage and mechanics. This class also focuses on Biographies.

51035 Language Arts (Grade 7)

Language Arts (Grade 7) courses build upon students' prior knowledge of grammar, vocabulary, word usage, and the mechanics of writing, and include the four aspects of language use: reading, writing, speaking, and listening. Beyond emphasizing different uses for language, these courses may also include using language (particularly written text) to construct meaning and connections. Specific content depends upon state standards for grade 7.

510351 Advanced Language Arts (Grade 7)

Advanced Language Arts 7 courses build upon students' prior knowledge of grammar, vocabulary, word usage, and the mechanics of writing, and include the four aspects of language use: reading, writing, speaking, and listening. Beyond emphasizing different uses for language, these courses may also include using language (particularly written text) to construct meaning and connections. Specific content depends upon state standards for grade 7. This class also focuses on the theme of persuasion.

51036 Language Arts (Grade 8)

Language Arts (grade 8) courses build upon students' prior knowledge of grammar, vocabulary, word usage, and the mechanics of writing, and include the four aspects of language use: reading, writing, speaking, and listening. Typically, these courses use various genres of literature to improve reading skills, and they link writing exercises for different purposes to those reading selections. Specific content depends upon state standards for grade 8.

510361 Advanced Language Arts (Grade 8)

Advanced Language Arts 8 courses build upon students' prior knowledge of grammar, vocabulary, word usage, and the mechanics of writing, and include the four aspects of language use: reading, writing, speaking, and listening. Beyond emphasizing different uses for language, these courses may also include using language (particularly written text) to construct meaning and connections. Specific content depends upon state standards for grade 8. This class also focuses on the theme of persuasion.

Mathematics

Students in the middle grades use problem-solving, computation, mathematical communication and reasoning, connections, and representations to integrate understanding within and across all content strands. Placement in accelerated math courses is based upon prior academic achievement including, but not limited to: classroom assessments, SOL performance, and other standardized assessments. Students failing to make adequate progress in an accelerated mathematics course may be moved to the grade-level course. The principal has the authority to make final decisions regarding placement in accelerated math courses.

In middle grades, the focus of mathematics learning is to:

- Build upon students' concrete reasoning experiences developed in the elementary grades;
- Construct, through active learning experiences, a more advanced understanding of mathematics to include the integration of technology;
- Develop deep mathematical understandings required for success in abstract learning experiences;
- Apply mathematics as a tool to real-life problems.

520360 Mathematics Grade 6

This math course emphasizes skills in numerical operations (including basic operations and their proper order); measurement; patterns; simple functions; geometry; and concepts of data analysis, including statistics and probability. Specific content depends upon state standards for Grade 6. Some students may be scheduled for an Intervention period for additional skill development; placement will be based upon prior academic achievement including, but not limited to, fifth grade classroom performance, assessment history, SOLs, math assessments, screenings, standardized test scores, etc.

020361 Pre-Algebra 6

In order to prepare students for Algebra I in grade 7, this class will move at an accelerated pace to cover the math Standards of Learning in Grades 6-8. Topics include numbers and operations, proportional reasoning, algebra, functions, two- and three-dimensional measurement and geometry, probability, and data analysis. Students completing this course are required to take the Grade 8 Mathematics SOL assessment.

520377 Mathematics Grade 7

This math course emphasizes proficiency in skills involving numbers and operations; measurement; patterns; functions; algebraic formulas; geometry; and concepts of data analysis, including statistics and probability. Specific content depends upon state standards for Grade 7.

020378 Pre-Algebra 7

In order to prepare students for Algebra I in Grade 8, this class will move at an accelerated pace to cover the math Standards of Learning in Grades 7-8. Topics include numbers and operations, proportional reasoning, algebra, functions, two- and three-dimensional measurement and geometry, probability, and data analysis. Students completing this course are required to take the Grade 8 Mathematics SOL assessment.

52038 Mathematics (Grade 8)

Mathematics (Grade 8) courses typically emphasize proficiency in skills involving numbers and operations, measurement, patterns, simple functions, algebra, geometry, statistics, and probability. Specific content depends upon state standards for Grade 8.

02052 Algebra I (Grade 7, 8)

Algebra I courses include the study of properties and operations of the real number system; evaluating rational algebraic expressions; solving and graphing first degree equations and inequalities; translating word problems into equations; operations with and factoring of polynomials; and solving simple quadratic equations.

314305 Honors Geometry (Grade 8)

Geometry courses, emphasizing an abstract, formal approach to the study of geometry, typically include topics such as properties of plane and solid figures; deductive methods of reasoning and use of logic; geometry as an axiomatic system including the study of postulates, theorems, and formal proofs; concepts of congruence, similarity, parallelism, perpendicularity, and proportion; and rules of angle measurement in triangles.

Science

532360 Science Grade 6

Science (Grade 6) encompasses subject matter from several strands of science, including earth/space sciences, physical sciences, and life or environmental sciences, and may organize material around thematic units, laboratory demonstrations, experimental design process, applicable mathematics concepts, individual research and group activities, and classroom instruction. Specific content depends upon state standards for Grade 6.

53158 Life Science Grade 7

Life Science courses cover the basic principles of life and life processes. These topics may include cells, species, ecosystems, reproduction, genetics, or other topics consistent with state academic standards for life science.

53159 Physical Science Grade 8

Physical Science (prior-to-secondary) courses cover basic principles of physical science, such as matter, energy, force, and motion. Topics may include conservation of energy and matter, the atomic model, the periodic table, electricity, or other topics consistent with state academic standards for physical science. Particular Topics in Physics courses concentrate on a particular subtopic within the field of physics (such as optics, thermodynamics, quantum physics, and so on) that is not otherwise described in this classification system.

History and Social Studies

541496 United States History I (Grade 6)

United States History I emphasizes United States History up to 1865, including fundamental concepts in civics, economics, and geography. Map and globe skills, skills in interpreting and using information, and historical thinking skills will be reviewed and strengthened.

541497 United States History II (Grade 7)

United States History II emphasizes United States History from 1877 to present, including fundamental concepts in civics, economics and geography. Map and globe skills, skills in interpreting and using information, and historical thinking skills will be reviewed and strengthened.

54161 Civics and Economics (Grade 8)

Civics courses examine the general structure and functions of American systems of government, the roles and responsibilities of citizens to participate in the political process, and the relationship of the individual to the law and legal system. These courses do not typically delve into the same degree of detail on constitutional principles or the role of political parties and interest groups as do comprehensive courses in U.S. Government.

Health & Physical Education

58052 Health and Physical Education (Grades 6-8)

Health and Physical Education is a required course in grades 6-7 and available to students in grade 8 as an elective option. Health and Physical Education includes instruction in Health (e.g. Body Systems for Fitness, Nutrition, Personal Health Management and Healthy Lifestyles, Sexual Education, Personal Safety) and instruction in Physical Education (e.g. Physical Fitness and Conditioning, Rhythmic Activities and Dance, and Game Skills for most team and individual sports). The courses involve the progressive acquisition and application of knowledge and skills that provide the foundation for sports, physically healthy and active lifestyles, and social development and emotional wellness through physical activity. Activities typically include those that increase strength, endurance, and flexibility; reinforce safe technique; teach the rules and conventions of games and sports; and explore the relationship between physical activity, health, and emotional wellness. Health topics also may include study of the effects of drugs and alcohol, sexual education, and healthy lifestyles.

Career and Technical Education

Computer and Information Sciences

620056 Keyboarding (Grades 6/7)

Keyboarding provides students with an introduction to the keyboard (letters, numbers, and symbols), basic machine operation, and proper keystroke technique. As students progress, they improve their speed and accuracy, produce increasingly complex documents, and apply composition skills on the word processor that will be beneficial in core academic courses. The course helps students develop keyboard proficiency, document production skills, and problem-solving skills. Keyboarding is a middle school requirement and also a pre-requisite for several subsequent CIS courses.

600100 Computer Solutions (Grade 7/8)

Students will be utilizing the computer as a problem-solving tool. A variety of projects incorporating word processing, database, presentation, and spreadsheet software will be included in this course. The use of computers in modern society, telecommunications, basic Internet safety, computer maintenance issues and workplace readiness skills also will be explored. **(Keyboarding is a pre-requisite for this class.)**

Engineering and Technology

Project Lead The Way (PLTW) prepares students to be the most innovative and productive leaders in Science, Technology, Engineering, and Mathematics (STEM) and to make meaningful, pioneering contributions to our world. PLTW partners with Page and Peasley Middle Schools to provide a rigorous, relevant STEM education. Through an engaging, hands-on curriculum, PLTW encourages the development of problem-solving skills, critical thinking, creative and innovative reasoning, and a love of learning. The PLTW middle school STEM education programs give students a brighter future by providing them with a foundation and proven path to college and career success in STEM-related fields. STEM education is at the heart of today's high-tech, high-skill global economy. For America to remain economically competitive, our next generation of leaders must develop the critical-reasoning and problem-solving skills that will help make them the most productive in the world. PLTW sparks the ingenuity, creativity, and innovation within all of our students.

710516 [8482] Introduction to Technology (Grade 6)

Students study the resources of all technology, including tools, energy, materials, people, time, information, and capital. This also includes the problem-solving process and various hands-on activities. They explore up to six systems of technology, including medical, agricultural and related biotechnologies, energy and power, information and communication, transportation, manufacturing, and construction. Students relate the impact of technology on society, environment, and culture to future consequences and decisions.

710026 [EE8479] PLTW Energy and the Environment (Grade 6)

Students are challenged to think big and toward the future as they explore sustainable solutions to our energy needs and investigate the impact of energy on our lives and the world. Students will design and model alternative energy sources and evaluate options for reducing energy consumption.

710027 [DM8476] PLTW Design and Modeling (Grade 7)

Students apply the design process to solve problems and understand the influence of creativity and innovation in their lives. They work in teams to design a playground and furniture, capturing research and ideas in their engineering notebooks. Using Autodesk® design software, students will create a virtual image of their designs and produce a portfolio to showcase their innovative solutions.

710028 [AR8476] PLTW Automation and Robotics (Grade 8)

Students trace the history, development, and influence of automation and robotics as they learn about mechanical systems, energy transfer, machine automation, and computer control systems. Students will use the VEX Robotics® platform, to design, build, and program real-world objects such as traffic lights, toll booths, and robotic arms.

710029 [CS8479] PLTW Computer Science For Innovators & Makers (Grades 6-8)

Studies suggest that by 2018, 1.4 million jobs will be available for computer specialists. In this course, students discover the principles of this fast-growing field by focusing on creativity and an iterative design process as they create their own basic apps using MIT App Inventor software.

Visual and Performing Arts

Music

General Band

General Band courses develop students' technique for playing brass, woodwind, and percussion instruments and cover a variety of non-specified band literature styles (concert, marching, orchestral, and modern styles). All Band courses in middle school are year-long.

551011 Beginning Band (Grades 6-7)

Beginning Band provides an opportunity for students to develop the interpretive, technical, and disciplinary skills needed to play a band instrument in a group activity. Emphasis is placed on individual skill development that also requires daily practice. Some after school rehearsals will be required in preparation for performances in the school and community throughout the year. Students are expected to obtain an instrument through the school, a rental program, or on their own. There is an annual fee of \$15.00 for sheet music, as well as \$15-\$20 Band uniform fee. Some out of class performances may be required.

551012 Intermediate Band (Grades 7-8)

Intermediate band is open for any band student who has completed a minimum of one year of band studies. This class will provide students with the opportunity to continue to develop skills necessary to continue with band at the high school level. The class will focus on developing technical as well as interpretive skills needed to participate in a performance oriented class. This class requires a daily practice log, scale playing tests, and after school performances and festival competitions throughout the year. Students are required to have an instrument for participation either through a private rental service, their own instrument, or a rental through GCPS. There is an annual fee of \$15.00 for sheet music, as well as \$15-\$20 Band uniform fee.

551013 Advanced Band (Grade 8)

Advanced band is offered to students who are recommended by their previous band director, and have a minimum of one year of band studies. Most students recommended for this class are beginning their third year of band studies. Eight Major scales as well as a one octave chromatic scale should be memorized and the student should be able to play these fluently as a minimum requirement. All students will be required to maintain a practice log, as well as participation in all concerts and other performances. Students in the advanced band may audition for all district band, fleet forces band, or be recommended for the Virginia Tech Honor band. Students are required to have an instrument for participation either through a private rental service, their own instrument, or a rental through GCPS. There is an annual fee of \$15.00 for sheet music, as well as \$15-\$20 Band uniform fee.

551106 Chorus (Grades 6)

Chorus 6 is primarily a vocal course where students not only will learn the fundamentals of singing, but also will explore and develop skills that promote confidence in singing alone and with others. Students will learn how the singing voice develops through the secondary school years and learn to sing a variety of choral literature styles for men's and/or women's voices and are designed to develop vocal techniques and the ability to sing parts. Chorus emphasizes the development of vocal technique, the understanding and application of traditional music notation and ensemble participation. These standards require performance, creativity, and investigation. Opportunities are provided for students to explore the relationship between music and the other fine arts and between music and disciplines outside the arts. Some out-of-class performances are required. Students must purchase the approved chorus apparel (approximately \$15-\$20).

551107 Chorus (Grades 7)

Chorus 7 is primarily a performing course where students will improve skills that are important for group and individual singing. All aspects of choral singing will be explored and songs and activities will include music written in unison, two, and three parts. Students also will continue to improve music reading and listening skills. There may be a fee associated with this course.

551108 Chorus (Grades 8)

Chorus 8 is a year-long performing course where students will continue to improve and refine vocal skills. All aspects of choral singing will be explored and songs and activities will include music written in unison, two, and three parts. Students also will continue to improve music reading and listening skills and participate in school and community performances. There may be a fee associated with this course.

551390 Music Exploration (6-8)

Music Exploration is a non-performing class where students are immersed in interactive technology to learn about music. In addition to learning the fundamentals of music, students will learn to compose their own music using computers. No formal music training or special technical skills are required. At the end of the semester, each student will produce an audio CD or podcast of music and digital imagery that he/she has created in class. Music and musicians of the Jazz age will also be studied.

551497 Guitar Adventures (Grades 7/8)

Students will learn the basic skills of playing the guitar. Along with playing, the students will learn basic music notation for guitarists. Three areas of playing will include melody, chords and bass. After school practice is required using the text and a school guitar. A class fee of \$10 provides a student book and guitar usage. Students are expected to play alone and with others.

Visual Arts

551860 Art Exploration (Grade 6)

Art courses provide students with activities that foster creative expression, communication through artistic endeavor, and appreciation of culture and heritage. In the Exploration course, students will develop the concepts and thinking skills necessary for understanding and producing art through various media and techniques, including drawing, design, painting, collage, crafts, sculpture, and printmaking. Activities may include those that enable students to refine their technique, increase their artistic vocabulary, express themselves and their world view, make connections to other content areas, develop their own aesthetic, and strengthen their critical abilities. Students will be expected to begin and maintain a portfolio throughout the semester, in addition to maintaining a sketchbook of assigned drawings. These courses also may include other forms of art (e.g. dance, music, theater). Art history, criticism, and aesthetics comprise a portion of this class. Specific course content conforms to any existing state standards for grade 6.

55187 Understanding Art (Grade 7)

This course builds upon the developing skills from the Exploratory course and helps to establish a foundation for higher level visual arts skills. The first half of this semester course is dedicated to drawing techniques (e.g. gesture and contours, two-point perspective, shading), painting, and graphic design/computer art. The second half of this course emphasizes 3-D techniques with materials such as clay, paper mache, and textiles. Students will be expected to expand and enhance their portfolio throughout the semester, in addition to maintaining a sketchbook of assigned drawings. Art history, criticism, and aesthetics comprise a portion of this class.

55188 Art (Grade 8)

Students will apply skills and techniques from prior art courses, as well as more sophisticated tools and materials, to create increasingly abstract works in preparation for high school visual arts courses and 2-D and 3-D designs. Art 8 course provides activities that foster creative expression, communication through artistic endeavor, and appreciation of culture and heritage. Activities may include those that enable students to refine their technique, increase their artistic vocabulary, express themselves and their world view, make connections to other content areas, develop their own aesthetic, and strengthen their critical abilities. Instruction also includes career exploration, as well as written assignments in art history, critique, and aesthetics. Students will be expected to expand and enhance their portfolio throughout the semester, in addition to maintaining a sketchbook of assigned drawings. Art history, criticism, and aesthetics comprise a substantial portion of this class.

World Language

560396 Introduction to World Language (Grades 6/7)

This introductory course is a general study of common words and everyday phrases in foreign languages (primarily French and Spanish), including greetings, numbers, and names of the days and months. Students will explore the language, geography, and culture of the Spanish and French speaking world and will participate in a general study of language and communication, its origin and historical development, sound patterns, writing systems, and words and meanings. Students will apply skills of listening, speaking, reading, and writing to build a foundation for learning a foreign language. Students will develop awareness and appreciation of other cultures through language perspectives.

560391 Foundations of French and Spanish (Grades 7/8)

This course is designed to be an introduction to French I and Spanish I. The initial course objectives emphasize grammar and syntax, vocabulary, and the spoken accent so that students have an understanding of the language and its rules. Objectives also advance students' knowledge and ability to express themselves beyond basic communication (and understand others, either in a written or verbal format), seeking to enable students to express more complex concepts, in different tenses, and to do so more easily. Students begin to explore the customs, history, and art forms of French and Spanish-speaking people to deepen their understanding of the cultures.

06101 Spanish I (Grade 8)

This year-long course for high school credit formally begins the Spanish language sequence that culminates in advanced-level language in high school. The course continues to develop skills of listening, speaking, reading, and writing, builds upon foundational knowledge of Spanish culture and customs, and emphasizes basic grammar and syntax, developing vocabulary, and the spoken accent so that students can read, write, speak, and understand the language in authentic, predictable contexts in Spanish-speaking countries.

06121 French I (Grade 8)

This year-long course for high school credit formally begins the French language sequence that culminates in advanced-level language in high school. The course continues to develop skills of listening, speaking, reading, and writing, builds upon foundational knowledge of French culture and customs, and emphasizes basic grammar and syntax, developing vocabulary, and the spoken accent so that students can read, write, speak, and understand the language in authentic, predictable contexts in French-speaking countries.

Middle School Course Expungement

When students below the ninth grade successfully complete courses offered for high school credit, the credit shall be counted toward meeting the standard units required for graduation, provided that the courses are equivalent in content and academic rigor as comparable courses offered at the high school level. To earn a verified unit of credit for these courses, students below ninth grade must meet the same requirements applicable to other students.

In any high school credit-bearing course taken prior to the student's ninth-grade year, the student's parent may request that the final grade be omitted from the student's high school transcript and the student not earn high school credit for the course. Such requests shall be made in writing to the middle school principal not later than the last day of June following the student's eighth grade year.

GHS Scheduling Policies and Procedures

Course Loads

- Students in grades 9 – 11 must carry 8 credits.
- Students in grade 12 must carry 6-8 credits.
- Early Out, Study Hall, Student Assistant, and SOL Intervention are not for credit.
- Any student seeking a reduced schedule must receive permission from a parent, a school counselor, and an administrator. Reduced schedules can be requested via the Course Selection Request Worksheet, the Early Out Request form, or the Exemption From Academic Policy form. Please see bulleted item #3 under Athletic Eligibility below.
- Only students in Grades 11 or 12 may request to serve as a student assistant to a qualified, eligible faculty member. Approvals are based upon student merit, potential for productive and effective contribution, and faculty need. Selections require administrator, counselor, and parent approval.

Athletic Eligibility

- Students must maintain a cumulative grade point average of 2.0 or have a previous semester grade point average of 2.0 to be eligible to participate in athletics.
- In addition, students must take and pass no fewer than the equivalent of three (3) credits per semester.
- Students and parents are responsible to ensure that students are eligible for VHSL teams and competitions.

Scheduling Information

- Corrections and changes to requests for next year's courses must be made in writing (no e-mails), with a parent signature, no later than May 15.
- Students requesting dual enrollment classes must complete the RCC Dual Enrollment application and receive the required VPT scores no later than May 15. Students who have not received the required VPT scores by May 15 will have the course removed from their requests and will not be able to take the dual course the next year.
- Once a semester begins, non-weighted classes cannot be changed. Students dropping a semester class after the fifth (5th) school day of a semester will receive a WF on their transcript. An Add/Drop form must accompany any request and be signed and initialed as required.
- Students may request to move from a semester-based weighted class to the non-weighted equivalent class during the first five (5) school days of a semester. Students will be permitted to move only if there is space available in the non-weighted class. An Add/Drop form must accompany the request and be signed and initialed as required.
- Students may request to move from a yearlong weighted class to the non-weighted equivalent class during the first ten (10) school days of the school year. Students will be permitted to move only if there is space available in the non-weighted class. An Add/Drop form must accompany the request and be signed and initialed as required.
- Academic honors-level courses are offered to students at all grade levels who wish to have a more rigorous and challenging course of study. Honors courses are weighted on the grading scale and are marked with an asterisk (*) on the transcript.
- Students/parents requests for specific teachers cannot be considered unless student previously failed same course with same teacher.
- Isolated/extreme cases involving exceptions to these procedures will be considered by the School Counselor and the Assistant Principal.
- Course offerings in this publication are subject to a variety of enrollment and staffing constraints including, but not limited to: (1) course demand or enrollment; (2) teacher availability or licensure; (3) redistricting; (4) other schedule or staffing conditions determined by the school principal. As a result, a course may be subject to cancellation by administrative decision. School personnel will communicate with students and families regarding changes to the school's master schedule that impact a student's primary course requests. Contact your child's school counselor if you have questions regarding course registration or availability.
- A student may repeat a course previously passed with a grade of "D" in order to strengthen academic skills. In the student's permanent record, the highest earned grade of the two will be averaged into the GPA. The lower grade will remain on the transcript. Only one credit toward graduation can be earned for each course.

Grade Point Average Calculation (Quality Point Scale)

- A = 4 Quality Points
- B = 3 Quality Points
- C = 2 Quality Points
- D = 1 Quality Point
- F or Withdraw Failing (WF) = 0 Quality Points
- Weighted courses add one (1) Point to A, B or C. No point is added for grades of D, F or WF.
- GPA Calculation Example on next page.

GPA Calculation Example:

Course	Course Grade	Quality Points	Attempted Credits	TQP/TAC= GPA
English 9 Honors	A	5	1	
World History I	C	2	1	
Algebra I	B	3	1	
Earth Science Honors	D	1	1	
French I	A	4	1	
Health/PE 9	B	3	1	
Elective	WF	0	1	
Totals		18 (TQP)	7 (TAC)	18/7=2.571

GHS Graduation Recognitions

Beginning with the GHS Class of 2022:

- Class rank will not be reported on school transcripts. Class rank will be used only for graduation recognition and not calculated for a class until after final grades are calculated at the conclusion of the senior year for a graduating class.
- Colleges and other post-secondary institutions will be provided information on GPA ranges for each graduating class on the “Gloucester High School Profile” document that accompanies official transcripts.
- Academic recognitions for each graduating class will be as follows:
 - Valedictorian – highest-weighted GPA
 - Salutatorian – second-highest weighted GPA
 - Summa Cum Laude – weighted GPAs 4.0 and above
 - Magna Cum Laude – weighted GPAs 3.75 - 3.999
 - Cum Laude – weighted GPAs 3.50 - 3.749

GCPS Grades 9-12 Curriculum

Career & Technical Education

Students who complete a career and technical education program sequence and pass an examination or occupational competency assessment in a career and technical education field that confers certification; or earn an occupational competency credential from a recognized industry, trade, or professional organization; or acquire a professional license in a career and technical education field from the Commonwealth of Virginia may substitute the certification, competency credential, or license for (i) the student-selected verified credit and (ii) either a science or history and social science verified credit when the certification, license, or credential confers more than one verified credit. The examination or occupational competency assessment must be approved by the Board of Education as an additional test to verify student achievement. *See page 30 for a complete listing of certification exams, industry certifications, and licenses.*

Virginia continues to be a national leader in aligning career and technical education programs with business and industry expectations. Students who earn one or more nationally recognized credentials have a distinct advantage in entering their chosen field of employment and/or in continuing their career preparation through post-secondary education.

Business and Information Technology Courses

Business and Information Technology courses are designed to offer students the attainment of competencies for work, further education and training, and personal use goals. All students are provided opportunities to complement their academic preparation through the Business and Information Technology program. The curriculum for this department not only meets current technological advances in computer applications, systems, and communications, but also presents opportunities to learn about finance, banking and credit, financial planning, accounting, business law, management and Dressing for Success.

The Future Business Leaders of America (FBLA) is the Career and Technical Education student organization designed to develop personal employability and leadership skills for all individuals enrolled in business and information technology courses. Through participation in the organization, the business students learn to engage in individual and group business enterprises, to hold office and direct the affairs of a group, to work with representatives of other student organizations, and to compete honorably with their colleagues.

GHS Course No.	Course Title	Credit	9	10	11	12	Recommendation
612020	Economics and Personal Finance	1		x	x	x	Algebra I
661200	Computer Information Systems	1	x	x	x	x	Keyboarding Skills
661300	Computer Information Systems (Advanced)	1		x	x	x	Computer Information Systems
811000	Introduction to Marketing	1	x	x	x		None
817500	Sports, Recreation & Entertainment Marketing	1		x	x	x	None
906200	Virginia Teachers for Tomorrow	1			x	x	None
909700	Leadership Development	1			x	x	Freshman Mentors Only
909300	Entrepreneurship Education	1	x	x	x	x	None
909400	Entrepreneurship Education (Advanced)	1		x	x	x	Entrepreneurship Education
9826WB	Internship/Work-Based Learning Experience	1			x	x	Application & Interview Required

ECONOMICS AND PERSONAL FINANCE

Number: 612020
Recommendation: Algebra I
Credit: 1
Grade: 10-12

Economics and Personal Finance is designed for students to explore basic economic concepts and personal financial planning. Upon completion of this course, students will be able to demonstrate knowledge of the price system, the nation's financial system, how monetary and fiscal policy influences employment, the role of government in a market economy, the global economy, and the nation's economic goals. Students will also learn knowledge of consumer skills, planning for living and leisure expenses, banking transactions, credit and loan functions, role of insurance in risk management, income earning, taxes, investment and savings planning, and the financial implications of an inheritance. Students will prepare for Wise Certification testing at the completion of this course. *This course is a graduation requirement for the Class of 2015 and beyond.*

COMPUTER INFORMATION SYSTEMS

Number: 661200
Recommendation: Keyboarding Skills
Credit: 1
Grade: 9-12

Computer Information Systems is designed to introduce students to applications using word processing, spreadsheet, personal management (Outlook), multi-media presentation (PowerPoint), and database software. Students will apply problem-solving skills to real-life situations. Students have the opportunity to earn a Microsoft Office Specialist Certification.

COMPUTER INFORMATION SYSTEMS (ADVANCED)

Number: 661300
Recommendation: Computer Information Systems
Credit: 1
Grade: 10-12

Students apply problem-solving skills to real-life situations through advanced integrated software applications, including printed, electronic, and Web publications. Students work individually and in groups to explore advanced computer maintenance activities, Web site development, programming, networking, emerging technology, and employability skills.

INTRODUCTION TO MARKETING

Number: 611500
Recommendation: None
Credit: 1
Grade: 9-10

Students gain an understanding of the importance of marketing in today's society. They develop skills related to interpersonal communication, self-presentation, economics, marketing, sales, employability, career discovery, and ethical decision-making. This course reinforces mathematics, science, English, and history/social science Standards of Learning. Computer technology applications and DECA activities support this course. DECA, the co-curricular student organization, offers opportunities in leadership, community, and competitive events.

SPORTS, RECREATION & ENTERTAINMENT MARKETING

Number: 817500
Recommendation: None
Credit: 1
Grade: 10-12

This introductory course helps students develop a thorough understanding of fundamental marketing concepts and theories as they relate to sports, entertainment, and recreation industries. Students will investigate the components of branding, sponsorships, and endorsements, as well as promotion plans needed for sports, entertainment and recreation events. The course also supports career development skills and explores career options.

ENTREPRENEURSHIP EDUCATION

Number: 909300
Recommendation: None
Credit: 1
Grade: 9-12

Students will be introduced to the exciting world of planning, for, creating, owning, and launching their own business enterprise. Students will learn concepts and techniques for planning and operating an innovative business and realizing an entrepreneurial lifestyle.

ENTREPRENEURSHIP EDUCATION (ADVANCED)

Number: 909400
Recommendation: Entrepreneurship Education
Credit: 1
Grade: 10-12

This course is designed for students who wish to concentrate on advanced strategies for entrepreneurship, building upon concepts introduced in Entrepreneurship (9093). The focus of the course is on development of a business plan and small business management. Students will establish, market, and maintain a business model.

LEADERSHIP DEVELOPMENT

Number: 909700
Recommendation: Recommendation of Faculty Member
Credit: 1
Grade: 10-12

Students develop competencies in identifying individual aptitudes in relation to effective leadership skills, understanding organizational behavior, using effective communication in the workplace, handling human resources and organizational problems, supervising and training employees, resolving conflict, and planning for the future. Continuing education in leadership is emphasized as well as practical leadership experiences in cooperation with school and community leaders.

VIRGINIA TEACHERS FOR TOMORROW

Number: 906200
Recommendation: Leadership Development
Credit: 1
Grade: 11-12

This course fosters student interest, understanding, and appreciation of the teaching profession and allows high school students to explore careers in education. Students build a foundation for teaching, learn the history, structure, and governance of teaching, apply professional teaching techniques in the VTFT classroom and field experience, and reflect on their teaching experiences. Additional educational leadership opportunities are offered through the student organization, *Educators Rising*.

INTERNSHIP/WORK-BASED LEARNING EXPERIENCE

Number: 9826WB
Recommendation: Application and Interview Required
Credit: 1
Grade: 11-12

The Internship/WBL Experience is a planned, structured, and supervised educational activity or program that enables the student to practice and develop career-related skills in an actual workplace environment in a particular industry or occupation related to the student's career interests, abilities, and goals, allowing the student to document job-related experiences. Prior to the internship placement, the student receives the established criteria and guidelines from the division Coordinator and workplace supervisor. Throughout the internship, the supervisor evaluates the student's progress. The Internship/WBL experiences are scheduled for a specified period of time during the school year and/or summer and may be paid or unpaid. Students must adhere to standards and regulations established for these experiences which will be supervised by a trained WBL Coordinator. The Internship/WBL experience is a PASS/Fail course and not calculated into the student's cumulative grade-point average.

Agricultural Education

The Agricultural Education discipline contains five programs of study. These programs are designed to prepare students to enter various occupations in horticulture, agricultural business, natural resources management, agricultural machinery, and production agriculture.

Agricultural Education stresses the development of skills in all aspects of agricultural businesses and industries. Included in the studies are skills related to planning, management, safety, finances, and leadership.

An integral part of the agricultural education program is the FFA. The FFA provides all agricultural education students opportunities to apply knowledge and skills learned in the classroom. Leadership activities enhance the experiences of the students.

Second, third and fourth year agricultural education courses are offered for Dual Enrollment credit through RCC. Students will be required to complete the RCC application and Placement Test to be considered for these upper level courses.

GHS Course No.	Course Title	Credit	9	10	11	12	Recommendation
808600	Biological Applications in Agriculture	1	x	x	x		None
808800	Veterinary Science	1			x	x	Biology and Biological Applications in Agriculture
803400	Horticulture Dual*	1		x	x	x	Biological Applications in Agriculture
803500	Greenhouse Management & Plant Production Dual*	1			x	x	Introduction to Plant Systems
803600	Landscaping Dual*	1				x	Greenhouse Management & Plant Production Dual*

*Students interested in honors, dual enrollment or Advanced Placement classes should consult their current teacher prior to requesting the course.

BIOLOGICAL APPLICATIONS IN AGRICULTURE

Number: 800600
Recommendation: None
Credit: 1
Grade: 9-11

This course is designed to integrate science and agriculture in the Agricultural Education classroom. Students explore the world of agriculture and its biological principles. Competencies emphasize and reinforce Standards of Learning for Biology with agricultural applications.

VETERINARY SCIENCE

Number: 808800
Recommendation: **Biology and Biological Applications in Agriculture**
Credit: 1
Grade: 11-12

This course enables students to acquire the employability and technical knowledge and skills needed to succeed in postsecondary education as well as in a career in veterinary medicine or a related occupation. Course content integrates application of academics, development of career competencies, and instruction in course-specific knowledge and skills such as the use of tools, equipment, and facilities related to veterinary medicine. Business management, leadership, and FFA activities are included in the course. Students enrolled should have a strong background in math and science and should be familiar with small animal care.

HORTICULTURE DUAL ENROLLMENT *

Number: 803400
Recommendation: **Biological Applications in Agriculture**
Credit: 1
Grade: 10-12

Through laboratory activities, students apply scientific principles to the field of horticulture, including the areas of floriculture, landscape design, greenhouse operation, nursery plant production, and turf management. Students practice safety, develop leadership traits, use plant-growing media, and identify, propagate, and grow horticultural plants in the greenhouse and land laboratory.

FLORICULTURE: GREENHOUSE MANAGEMENT & PLANT PRODUCTION DUAL ENROLLMENT *

Number: 803500
Recommendation: **Introduction to Plant Systems**
Credit: 1
Grade: 10-12

Greenhouse Management is a research based application of efficient plant production in a controlled environment. The course is taught from both a scientific and business perspective. Students may take the Greenhouse Managers Certification Exam at the end of the course.

LANDSCAPING DUAL ENROLLMENT *

Number: 803600
Recommendation: **Greenhouse Management & Plant Production DE***
Credit: 1
Grade: 11-12

Landscaping is designed to meet the growing demand for managers in the greenhouse and landscaping industry. All phases of the program are covered with emphasis on installation and maintenance of interior and exterior landscapes. Students interested in studying landscape architecture and design as well as those who are interested in managing a landscape business would profit from this course.

Technology Education

The technology education program provides experiences that lead to the development of technologically literate people. Consistent with their abilities, interests, and educational needs, students completing a technology education program will achieve the following goals:

- Comprehend the dynamics of technology, including its development, impact, and potential.
- Employ the technological processes of problem-solving, creating and designing.
- Analyze the behavior of technological systems and subsystems, including the tools, materials, processes, energy, information, and people involved in systems.
- Apply scientific principles, engineering concepts, and technological systems in the processes of technology.
- Discover and develop personal interests and abilities related to a wide variety of technology-oriented careers.

GHS Course No.	Course Title	Credit	9	10	11	12	Recommendation
843100	Construction Technology	1	x	x			
843500	Technical Drawing	1		x	x	x	
843650	Engineering Drawing	1		x	x	x	Technical Drawing
843700	Architectural Drawing	1		x	x	x	Construction Technology
846000	Modeling & Simulation Technology	1		x	x	x	None
840000	Game Design & Development	1	x	x	x		
840100	Game Design & Development, Advanced	1		x	x	x	Game Design & Development

663000	Multimedia & Web Design	1	x	x	x		Enrollment in the GHS Multimedia Program
663100	Multimedia & Web Design, Advanced	1		x	x	x	Multimedia & Web Design
845800	Graphic Communications	1		x	x	x	Modeling & Simulation Technology
630200	Cybersecurity Fundamentals	1	x	x			None
630400	Cybersecurity Software Operations	1		x	x		Cybersecurity Fundamentals
630600	Cybersecurity Software Operations, Advanced	1			x	x	Cybersecurity Software Operations

*Students interested in honors, dual enrollment or Advanced Placement classes should consult their current teacher prior to requesting the course.

CONSTRUCTION TECHNOLOGY

Number: 843100

Recommendation: None

Credit: 1

Grade: 9-10

Students design, build, and test scale model structures and work with projects that help them to understand the jobs of architects, carpenters, electricians, plumbers, surveyors, contractors, masons, design engineers, and a variety of other construction careers.

TECHNICAL DRAWING

Number: 843500

Recommendation: None

Credit: 1

Grade: 10-12

In this foundation course, students learn the basic language of technical design, while they design, sketch, and make technical drawings, illustrations, models, or prototypes of real design problems. Students develop spatial ability as they apply mathematical concepts to visual representations. The course is especially recommended for future engineering and architecture students. They also explore aspects of the construction industry by building projects that help them understand the jobs of architects, carpenters, electricians, plumbers, surveyors, contractors, masons, design engineers, and a variety of other construction careers.

ENGINEERING DRAWING & DESIGN

Number: 843650

Recommendation: Technical Drawing

Credit: 1

Grade: 11-12

Engineering Drawing/Design is an advanced drawing and design course which enables students to extend their knowledge of drafting concepts and the application of AutoCAD software. In addition to learning to develop working drawings and/or assembly drawings, students are challenged with design projects throughout the year.

ARCHITECTURAL DRAWING & DESIGN

Number: 843700

Recommendation: Construction Technology or Technical Drawing

Credit: 1

Grade: 10-12

Architectural Drawing/Design is an advanced drawing and design course which provides students the opportunity to learn about the principles of architecture and increase understanding of working drawings and construction techniques learned in the prerequisite course. Experiences include designing, rendering, and model making, including attention to structural details and community planning. Students use computer-aided drawing and design (CADD) equipment and established standards or codes. This course provides information helpful for the home owner/home builder and is especially beneficial to the future architect or designer.

MODELING & SIMULATION TECHNOLOGY

Number: 846000

Recommendation: None

Credit: 1

Grade: 10-12

Students will explore the use of modeling, simulation, and game development software to solve real-world problems in science, technology, engineering, and mathematics (STEM). The activities will include evaluating and testing engineering designs, modeling geospatial data, observing and analyzing physics simulations, programming games for educational purposes, and creating visualization systems with 3D models.

GRAPHIC COMMUNICATIONS SYSTEMS

Number: 845800
Recommendation: Modeling & Simulation Technology
Credit: 1
Grade: 10-12

This course provides experiences related to a wide range of tools and materials used to reproduce information and images. Several mediums are used, including paper, metal, plastic, and fabric. Students develop competencies in design and layout, composition and assembly, film conversion, image applications, message transfer, and print production.

GAME DESIGN & DEVELOPMENT

Number: 840000
Recommendation: None
Credit: 1
Grade: 9-11

In this project-based course, students will utilize contemporary design software to create innovative games through the application of graphic design, animation, audio, logic, and writing skills. Students will work in teams and utilize problem solving, critical thinking, and communication skills to analyze, design, prototype, and critique interactive games within a project management environment. Career opportunities across multiple industries, including education and entertainment, will be explored. Students will gain an understanding of the video game industry, including background, techniques, trends, challenges, and careers. Students will receive hands-on training in graphic design, game design, computer coding, and other technology skills.

GAME DESIGN & DEVELOPMENT, ADVANCED

Number: 840100
Recommendation: None
Credit: 1
Grade: 10-12

In this project-based course, students will work in collaborative teams to refine their game design skills as they apply graphic design, animation, audio, logic, and writing skills to create innovative games for education and entertainment. This project-based course enhances problem-solving, project management, and communication skills through the analysis, design, construction, operation, and critique of interactive games within a project management environment. Students will learn about career opportunities across multiple industries and investigate further education, training, and certification requirements. Students will gain an understanding of the video game industry, including background, techniques, trends, challenges, and careers. Students will receive hands-on training in graphic design, game design, computer coding, and other technology skills.

MULTIMEDIA & WEB DESIGN

Number: 663000
Recommendation: None
Credit: 1
Grade: 9-11

This course will be offered as part of a course "bundle" with Journalism and computer-based Art courses in the GHS Multimedia Program and will be the introductory course leading to industry certification(s) not offered through other journalism or art courses. Students will develop proficiency in designing and creating a variety of desktop-published projects and materials, multimedia presentations/projects, and websites, utilizing industry-standard application software. Students will apply principles of layout and design to complete projects and will create portfolios that include a resume and variety of desktop-published materials produced during the course. Intended outcomes include graphic design skills and industry certification in web design and/or animation.

MULTIMEDIA & WEB DESIGN, ADVANCED

Number: 663100
Recommendation: None
Credit: 1
Grade: 10-12

This course will be offered as a course "bundle" with Advanced Journalism and advanced computer-based Art courses in the GHS Multimedia Program and will be the capstone course leading to industry certification(s) not offered through other journalism or art courses. Students will develop advanced skills in designing and creating a variety of desktop-published projects and materials, multimedia presentations/projects, and websites, utilizing sophisticated application software. Students will continue to apply advanced principles of layout and design to complete projects and enhance portfolios of desktop-published materials produced during the course.

CYBERSECURITY FUNDAMENTALS

Number: 630200
Recommendation: None
Credit: 1
Grade: 9-10

Cybersecurity affects every individual, organization, and nation. This course focuses on the evolving and all-pervasive technological environment with an emphasis on securing personal, organizational, and national information. Students will be introduced to the principles of cybersecurity, explore emerging technologies, examine threats and protective measures, and investigate the diverse high-skill, high-wage, and high-demand career opportunities in the field of cybersecurity.

CYBERSECURITY SOFTWARE OPERATIONS (begins 2019-20)

Number: 630400
Recommendation: Cybersecurity Fundamentals
Credit: 1
Grade: 10-11

Cybersecurity Software Operations is designed to teach many aspects of computer support and network administration. Students learn networking concepts, from usage to components, and create peer-to-peer network systems and client server networks. Students learn how to install and configure network cards and connect them to networks; to install the operating systems; to create, set up, and manage accounts; to load software; and to establish, implement, and maintain network integrity security plans. This course may cover software-based network operating systems, such as Windows Server or Linux, to prepare students with a foundation in computer network administration.

CYBERSECURITY SOFTWARE OPERATIONS, ADVANCED (begins 2020-21)

Number: 630600
Recommendation: Cybersecurity Software Operations
Credit: 1
Grade: 11-12

Cybersecurity Software Operations, Advanced continues to teach aspects of network administration, focusing on the management and support of network users and systems. The topics covered include understanding the responsibilities of computer professionals, training end users, evaluating new technology, developing system policies, troubleshooting workstations, managing network services and protocols, and effectively using email and business communications. Students learn communication protocols, troubleshooting techniques for systems and client-server networks, website management, and other advanced networking topics. Techniques that are used to install operating systems, set up and manage accounts, load software, and create and implement security plans are taught. This course may provide instruction about software-based network operating systems, such as Windows Server or Linux. Instruction will emphasize preparation for industry certification.

Culinary Arts

The Culinary Arts programs facilitate student progress toward a set of unifying goals in the areas of academic achievement, cultural and environmental issues, health and safety, leadership and workplace ethics, and application of technology

GHS Course No.	Course Title	Credit	9	10	11	12	Recommendation
824900	Introduction to Culinary Arts	1	x	x			None
827500	Culinary Arts I Dual Enrollment*	2		x	x		Intro to Culinary Arts strongly recommended
827600	Culinary Arts II Dual Enrollment*	2			x	x	Culinary Arts I
827700	Culinary Arts III	1				x	Culinary Arts II

***Students interested in honors, dual enrollment or Advanced Placement classes should consult their current teacher prior to requesting the course.**

INTRO TO CULINARY ARTS

Number: 824900
Recommendation: None
Credit: 1
Grade: 9-10

Intro to Culinary Arts is an introduction course for the culinary arts programs. Students will receive an overview of the topics covered in the pre-management course covering food preparation, sanitation, presentation, and safety.

CULINARY ARTS I DUAL ENROLLMENT*

Number: 827500
Recommendation: Intro to Culinary Arts strongly recommended
Credit: 2
Grade: 10-11

This is the first year of a two-year nationally certified pre-management course offered with The National Restaurant Association's Educational Foundation. This course has been developed to be recognized by industry and post-secondary schools. Students are required to maintain a grade level of 75% in food handling and safety to remain in this course. Professionalism skills are critical to succeed, including: Arriving on time, calling in advance of absence, proper dress, and professional attitude. Students in this class will learn the theory of the industry as well as basic culinary skills. All kitchen work is performed within the safety and sanitation requirements of VA Health regulations. There is a minimum seat time requirement of 280 hours for this course.

CULINARY ARTS II DUAL ENROLLMENT*

Number: 827600
Recommendation: Culinary Arts I
Credit: 2
Grade: 11-12

This is the second year of a two-year nationally certified pre-management course offered with The National Restaurant Association's Educational Foundation. Students are required to maintain a grade level of 75% in food handling and safety to remain in this course. Professionalism skills are critical to succeed. This class has a strong emphasis on food preparation, presentation, sanitation, and workplace readiness skills. All kitchen work is performed within the safety and sanitation requirements of VA Health regulations. Upon successful completion of the course with a "C" average or better and logging the required and verified quality work experience hours, students will be certification candidates as long as they have passed both national exams in Culinary Arts I. There is a minimum seat time requirement of 280 hours for this course.

CULINARY ARTS III

Number: 827700
Recommendation: Culinary Arts II
Credit: 1
Grade: 12

Culinary Arts III provides students with an opportunity to enhance their skills in applying nutritional principles, implementing sanitation and safety standards, and exploring careers. Students have the prospect of specializing in one of the following food-preparation techniques: Baking and Pastry, Catering/Banquet, Restaurant/Business, or Quantity Foods. Critical thinking, practical problem solving, and entrepreneurial opportunities within the field of culinary arts are emphasized. Upon completion, Students review content and receive ServeSafe certification.

Health & Medical Sciences

The Health and Medical Sciences Service assists Health and Medical Sciences teachers/supervisors who prepare students at less than the baccalaureate degree level for service in disciplines related to medicine, nursing, and allied health programs through therapeutic, diagnostic, rehabilitative, managerial, and supportive services.

GHS Course No.	Course Title	Credit	9	10	11	12	Recommendation
830200	Introduction to Health & Medical Sciences	1	x	x			None
839000	Introduction to Nutrition for Health & Medical Sciences Dual*	1		x	x	x	RCC Placement Test
838350	Medical Terminology	1		x	x	x	

*Students interested in honors, dual enrollment or Advanced Placement classes should consult their current teacher prior to requesting the course.

INTRODUCTION TO HEALTH & MEDICAL SCIENCES

Number: 830200
Recommendation: None
Credit: 1
Grade: 9-10

Intro to Health and Medical Sciences is designed to introduce students to a variety of health occupations and to develop basic skills common to all health careers. Students will develop an understanding of all health careers and related occupations. Course content will include activities dealing with communication, problem-solving, and critical thinking. The course will explore current health care issues and trends and will be supplemented by interviews with selected health care workers. This class is a foundation course which contains generic skills and knowledge necessary for all occupational offerings.

INTRODUCTION TO NUTRITION FOR HEALTH & MEDICAL SCIENCES DUAL ENROLLMENT*

Number: 839000
Recommendation: RCC Placement Test
Credit: 1
Grade: 10-12

The basic nutrition course is designed to provide an opportunity for the student to gain an understanding of the nutritional component of health care. This course will enable the student to identify common food sources of nutrients and the purposes of these nutrients in the body. Nutrition also involves the study of regional, cultural, and religious patterns. Students will learn to apply principles of nutrition to his/her individual life-style. The growth and development course is designed to provide an opportunity for the student to gain an understanding of the normal growth and development process across the lifespan.

MEDICAL TERMINOLOGY

Number: 838350
Recommendation: None
Credit: 1
Grade: 10-12

Medical Terminology is designed to provide the student with an opportunity to gain an understanding of medical terms from Greek and Latin prefixes, suffixes, and word roots. The student also must exhibit mastery in the spelling, pronunciation, and definition of medical terms (80%). It involves self-direction and teacher guided study.

Naval Junior Reserve Officers Training Corps

NJROTC will, to the best of their ability and the ability of the cadet, carry out the following objectives: Develop informed and responsible citizens; strengthen character and help form good habits of self-discipline; promote an understanding of the basic elements for national security; & develop respect and understanding for the need of constituted authority in a democratic society. Sports physical is required.

GHS Course No.	Course Title	Credit	9	10	11	12	Recommendation
791300	Naval Science I	2	x	x	x	x	None
791600	Naval Science II	2		x	x	x	Naval Science I
791800	Naval Science III/Economics & Personal Finance	2			x	x	Naval Science II
791900	Naval Science IV	1				x	Naval Science IV

NAVAL SCIENCE I

Number: 791300
Recommendation: None
Credit: 2 (1 credit each for NJROTC-I and Health/PE 9)
Grade: 9-12

This entry-level course provides students with an introduction the NJROTC Program, including naval orientation, citizenship and government, leadership skills, wellness, fitness, and first aid. The curriculum includes two major areas of study: (1) The Cadet Field manual with an introduction to military drill, uniforms, military customs and courtesies, and (2) the Introduction to NJROTC with the history of the JROTC program including citizenship, and laws-authority-responsibility. Cadets will experience a balanced program of instruction in wellness including building health skills through exercise, nutrition, and lifetime planning. Successful completion of Naval Science I also fulfills the requirements for Health/PE 9. Fees for new students are approximately \$25. A sports physical is required.

NAVAL SCIENCE II

Number: 791600
Recommendation: Naval Science I
Credit: 2 (1 credit each for NJROTC-II and Health/PE 10)
Grade: 10-12

Naval Science II involves academic and practical teaching in the following areas: Naval Orientation; Naval Leadership; Naval History (Civil War- World War II); Oceanography; Navigation Fundamentals; Naval Operations and Communications; Naval Intelligence and National Security; Shipboard Evaluations; Drill Commands and Ceremonies. Successful completion of Naval Science II also fulfills the requirements for Health/PE 10. Fees for new students are approximately \$25. A sports physical is required.

NAVAL SCIENCE III and ECONOMICS & PERSONAL FINANCE (EPF)

Number: 791800
Recommendation: Naval Science II
Credit: 2 (1 credit each for NJROTC-III and EPF)
Grade: 11-12

Naval Science III/EPF involves academic and practical teaching in the following areas: Naval Leadership and Discipline; the Naval Service-A Rewarding Way of Life; The US Navy in American Democracy; Naval History-Global War at Sea; Russian Studies; Sea Power Today: Meteorology and Weather; Astronomy; Maneuvering Board and Seamanship Afloat; Survival Training; Drills, Commands, and Ceremonies. In addition, students also will explore basic economic concepts and personal financial planning, and be able to demonstrate knowledge of the price system, the nation's financial system, how monetary and fiscal policy influences employment, the role of government in a market economy, the global economy, and the nation's economic goals. Students will learn consumer skills, planning for living and leisure expenses, banking transactions, credit and loan functions, role of insurance in risk management, income earning, taxes, investment and savings planning, and the financial implications of an inheritance. Students will prepare for Wise Certification testing at the completion of this course. ***This course is a graduation requirement for the Class of 2015 and beyond.***

NAVAL SCIENCE IV

Number: 791900
Recommendation: Naval Science III
Credit: 1
Grade: 12

Naval Science IV involves academic and practical teaching in the following areas: Naval Leadership; Training and Evaluation; Applied Citizenship; Military Justice; International Law and the Sea; Naval History-Post World War II; National Strategy and Naval Operations; Electricity and Naval Electronics; Weapons Systems; Challenges of the Future; Drills, Commands, and Ceremonies; and Cultural Studies, An Introduction to Global Awareness.

Trade & Industrial Arts

GHS Course No.	Course Title	Credit	9	10	11	12	Recommendation
852700	Cosmetology I	2		x	x		Approximate \$160 cost
852800/852900	Cosmetology II/III	2/2			x	x	Cosmetology I
850600/867200	Automotive Technology I	2		x	x		Algebra I
850700	Automotive Technology II	2			x	x	Automotive Technology I
850800	Automotive Tech III CO-OP	2				x	Automotive Technology II

*Students interested in honors, dual enrollment or Advanced Placement classes should consult their current teacher prior to requesting the course.

COSMETOLOGY I

Number: 852700
Recommendation: None
Credit: 2
Grade: 10-11

Cosmetology I is an introductory program to the art, science, and business of beauty culture. The units of study include basic skills in hair cutting, hair styling, manicuring, makeup application, permanent waving, hair coloring and lightening. The skills developed in this course will prepare a student for Cosmetology II. *Students will purchase cosmetology equipment. Approximate cost is \$180.*

COSMETOLOGY II and III

Number: 852800/852900
Recommendation: Cosmetology I
Credit: 2/2
Grade: 11-12

Cosmetology II & III offer a more in-depth study of the principles of cosmetology in a two double-block course. The units of study will continue to build on the basic skills developed in the first year of study with the addition of advanced techniques. The introduction of nail sculpturing, nail art, skin care, facials, cells, anatomy and physiology are included. Emphasis is given to customer relations and salon management, preparing the student for entry level employment upon passing the state licensing examination.

AUTOMOTIVE TECHNOLOGY I

Number: 850600/867200
Recommendation: Algebra I
Credit: 2
Grade: 10-11

Automotive Technology I is one year program focusing on four major areas: brakes, suspension and steering, electricity and electronics, engine performance, and engine repair. This course is designed for students with limited or no knowledge of automotive functions and covers theory as well as practical application. Safe shop conditions and industrial tools provide a realistic shop environment. Additionally, to authenticate the learning, students are trained using school owned vehicles. Students also will learn all safety-related practices and techniques.

AUTOMOTIVE TECHNOLOGY II

Number: 850700
Recommendation: Auto Tech I
Credit: 2
Grade: 11-12

In Automotive Technology II, there is more of an opportunity for students to perform hands-on shop skills in a double block setting. Students will develop advanced skills in shop operations, tool use, and procedures used in today's automotive technology industry. Internships at various auto servicing businesses may be available to students in good academic standing and with instructor recommendation.

AUTOMOTIVE TECHNOLOGY III CO-OP

Number: 850800
Recommendation: Auto Tech II
Credit: 2
Grade: 12

Auto III Co-Op offers students experiences in auto technology and the opportunity for workplace experiences in local automotive shops. Students will prepare for the ASE Certification exam.

Industry Certification Exams & Licenses

Students are encouraged to work toward earning an industry certification, to achieve state licensure, or pass an occupational competency assessment while pursuing a high school diploma. Students who earn a credential and complete a Career and Technical program may earn up to two student-selected verified credits to meet graduation requirements. Students who enroll in a Career and Technical Education course at Gloucester High School will be provided opportunities to obtain two industry-approved credentials: 1) Workplace Readiness Skills; and 2) the credentialing assessment specific to each CTE course.

The Virginia State Board of Education approves for student-selected verified credit only those credentials that meet the following criteria:

- They must prepare students for an occupation or occupational area.
- They must be knowledge-based, as opposed to performance-based. Credentials may contain a performance-based component, but it is not required.
- They must be in a career and technical education field that confers a credential from a recognized industry, trade, or professional association or entity.
- They must be administered on a multi-state or international basis.
- They must be standardized and graded independent of the school in which the test is given.

The State Board of Education in Virginia has approved credentials for career and technical education (CTE) courses or course sequences. Go to <http://www.doe.virginia.gov/> for a chart of the credentials approved by the Virginia Board of Education for student-selected verified credit along with brief descriptions and the courses which may prepare a student for the approved examinations.

Students who complete a career and technical education program sequence and pass an examination or occupational competency assessment in a career and technical education field that confers certification; or earn an occupational competency credential from a recognized industry, trade, or professional organization; or acquire a professional license in a career and technical education field from the Commonwealth of Virginia may substitute the certification, competency credential, or license for (i) the student-selected verified credit and (ii) either a science or history and social science verified credit when the certification, license, or credential confers more than one verified credit. The examination or occupational competency assessment must be approved by the Board of Education as an additional test to verify student achievement.

GHS Course	Course Title	Credential Title
612020	Economics and Personal Finance	Virginia Workplace Readiness Skills
661200	Computer Information Systems I	Microsoft Office Specialist (MOS) – PowerPoint/Word
661300	Computer Information Systems (Advanced)	Microsoft Office Specialist (MOS) – Excel/Access
791300	NJROTC	Armed Services Vocational Aptitude Battery Examination (ASVAB)
803400	Horticulture Science	Private Pesticide Applicator Certification
803500	Greenhouse Management	Greenhouse Operators Certification Program
803600	Landscaping	Landscape Management Certification
808800	Veterinary Science	NOCTI Animal Systems Assessment
817500	Sports Marketing	Recreation, Amusements, and Attractions Assessment (NOCTI)
827500	Culinary Arts I	NOCTI Commercial Food (Code 4020)
827600	Culinary Arts II	NOCTI Restaurant Food & Beverage Services (Code 1286)
843500	Technical Drawing	AutoDesk Certified User Examination - AutoCAD
843600	Engineering Drawing	AutoDesk Certified User Examination – Inventor
843700	Architectural Drawing	SkillsUSA Architectural Drawing (Code 9313)
852700	Cosmetology I	SkillsUSA Customer Service
852800	Cosmetology II	SkillsUSA Cosmetology
852900	Cosmetology III	Virginia Board of Barbers & Cosmetology
850600/867200	Automotive Technology I	SkillsUSA Customer Service
850700	Automotive Technology II	Automotive Technician Examination (NATEF/ASE)
850800	Automotive Technology III	Automotive Technician Examination (NATEF/ASE)
909300	Entrepreneurship Education	SkillsUSA Customer Service

English

HS Course No.	Course Title	Credit	9	10	11	12	Recommendation
011010	English SOL Intervention	0				x	Passed English 11 but not Writing and/or Reading SOL
113000	English 9	1	x				None
113005	English 9 Honors*	1	x				<i>Required Summer Reading.</i>
114000	English 10	1		x			English 9
114005	English 10 Honors*	1		x			English 9 and <i>required Summer Reading.</i>
115000	English 11	1			x		English 10
115010	American Studies English 11	1			x		English 10 and co-enroll in American Studies US History.
119505	English 11 Advanced Placement*	1			x		English 10 and <i>required Summer Reading.</i>
116000	English 12	1				x	English 11
116055	English 12 Dual Enrollment*	1				x	English 11 and RCC Placement Test required.
119605	English 12 Advanced Placement*	1				x	English 11 and <i>required Summer Reading.</i>
116010	English 12 CS	1				x	English 11 and college bound
571000	English as Second Language (ESL)	1	x	x	x	x	Counselor/case manager recommendation only
120000	Journalism I	1	x	x	x		None
121100	Advanced Journalism	1		x	x	x	Journalism I
139900	Public Speaking	1	x	x	x	x	None
117100	Creative Writing	1			x	x	None

*Students interested in Honors, Dual Enrollment or Advanced Placement classes should consult with their current teacher prior to requesting the course.

ENGLISH SOL INTERVENTION

Number: 011010

Recommendation: Passed Eng 11 and not one or both English SOL tests

Credit: 0

Grade: 12

This class is designed for students who need to pass either the English Writing or the English Reading SOL to graduate.

ENGLISH READING INTERVENTION

Number: ORDINT

Recommendation: Did not pass English 8 Reading SOL and other assessment/placement criteria

Credit: 0

Grade: 10

This class is designed for students who need additional assistance and/or instructional intervention.

ENGLISH 9

Number: 113000
Recommendation: None
Credit: 1
Grade: 9

English 9 students will present and critique dramatic readings of literary selections and develop skills in making planned oral presentations. Knowledge of literary terms and forms will be applied in the students' own writing and in analysis of literature. Increased requirements for research and reporting in all subjects will be supported by the use of electronic databases and standard style sheet methods to cite reference sources. Writing will encompass narrative, literary, expository, and technical forms, with particular attention to analysis.

ENGLISH 9 HONORS*

Number: 113005
Recommendation: Required summer reading
Credit: 1
Grade: 9

This is an advanced course in literature which emphasizes analytical thought in reading, writing, and discussion. Students will analyze works that extend and enrich quarterly thematic concepts (three novel-length works per semester). Throughout the course, students will practice the four modes of writing (descriptive, expository, narrative, and persuasive) with an emphasis on developing multi-paragraph essays with three-point thesis statements. Students will be introduced to timed writing, research methods, & analytical projects. *Summer reading required.*

ENGLISH 10

Number: 114000
Recommendation: English 9
Credit: 1
Grade: 10

English 10 students will focus on communication in small group learning. Attention will be given to the analysis of printed consumer information, such as labels, owner's manuals, warranties, and contracts. Analysis skills will be applied to literary works from a variety of eras and cultures. The student will critique the writing of peers and professionals, using analysis to improve skills.

ENGLISH 10 HONORS*

Number: 114005
Recommendation: English 9 and required summer reading
Credit: 1
Grade: 10

Students will develop their knowledge and appreciation of literature by reading and analyzing literature linked to an overarching theme. The literature addresses various cultures and historical periods (links to World History II coursework), observes and reports on human behavior and choices, and explores both flaws and resilience in human nature and society. Participants will read classical and modern literature and produce critical essays concerning the characters, themes, and social issues within the works. Students will use different modes of writing in order to strengthen logical development of ideas in single paragraphs as well as in multi-paragraph essays while also refining editing skills and grammar knowledge. Students will be challenged to develop theses for individual and multiple literary works, to present ideas with creativity and originality, and to produce a properly-documented research paper. Students will continue developing diction/vocabulary knowledge. This class meets and exceeds the Virginia Standards of Learning for 10th grade and aligns with GHS grade-level curriculum. *Summer reading required.*

ENGLISH 11

Number: 115000
Recommendation: English 10
Credit: 1
Grade: 11

English 11 includes persuasive oral presentations with attention to the accuracy of evidence and the effectiveness of delivery. The students will study American literature and identify prevalent themes and characterizations. The student will be expected to write clear and accurate business correspondence and applications as well as expository and persuasive compositions. This course requires SOL testing in Reading and Writing.

AMERICAN STUDIES ENGLISH 11

Number: 115010
Recommendation: English 10 and co-enrolled with American Studies U.S. History
Credit: 1
Grade: 11
Offered: Double blocked with AS US History

The study of United States History and American Literature are natural partners for a joint investigation. The bridge created by jointly investigating literary works from each theme will promote a greater appreciation of both United States History and American Literature. Students will focus on reading and writing to increase their abilities to compare and contrast trends in American society and develop critical thinking skills. This focus will include a research paper where students reflect about the comparisons between the history and literature of the United States. An emphasis will also be placed on persuasive writing, speaking, and debating. Students will read a variety of genres from both primary and secondary sources. This course requires SOL testing in English Reading & Writing & U.S. History.

ENGLISH 11 ADVANCED PLACEMENT*

Number: 119505
Recommendation: English 10 and required summer reading
Credit: 1
Grade: 11

English 11 AP will provide an in-depth look into our country's literature while preparing students for the Language and Composition Advanced Placement Exam. Students will explore a representative body of literature that reveals our national history, culture, and character. In concert with this study of literature, students will continue to develop as mature readers, thinkers, and writers through analysis of nonfiction texts and seminar-style discussions. In particular, this course asks students to analyze and employ an array of rhetorical strategies and literary techniques, to make both written and oral persuasive presentations and to engage in all phases of formal research. This course requires SOL testing in Reading and Writing. *Students enrolled in this course are recommended to take the AP Examination in May. Summer reading required.*

ENGLISH 12

Number: 116000
Recommendation: English 11
Credit: 1
Grade: 12

English 12 students will plan and deliver 5-10 minute oral presentations. The reading focus of this course will be British literature and its historical context. Writing will include technical and expository papers and reports. The senior will also be required to produce a well documented research paper or project. The Senior Independent Research Study is included in this course.

ENGLISH 12 DUAL ENROLLMENT*

Number: 116055
Recommendation: English 11 grade and RCC Placement Test
Credit: 1
Grade: 12

English 12 Dual Enrollment is a college course which can be taken by students while they are still in high school. Time will be spent developing the various types of writing (descriptive, narrative, expository, etc.) as well as writing in response to literature. The college texts and curriculum will be supplemented by the Senior Independent Research Study experience required of all students.

ENGLISH 12 ADVANCED PLACEMENT*

Number: 119605
Recommendation: English 11 AP grade B and required summer reading
Credit: 1
Grade: 12

English 12 AP extends and enriches all of the qualities of English 12. Students will read at least nine novel-length works over the duration of the course and will produce (in addition to other writing) two critical essays per quarter. In addition, the course will be taught as a college-level course and may serve as college credit under certain conditions. Expectation of student skills and responsibility will reflect college expectations and provide preparation for the AP Literature test. The Senior Independent Research Study is included. *Students enrolled in this course are recommended to take the AP Examination in May. Summer reading required.*

JOURNALISM I

Number: 120000
Recommendation: None
Credit: 1
Grade: 9-11

Journalism I examines the historical, ethical and legal aspects of print and broadcast journalism. It provides the skills necessary for writing news stories, sports stories, editorials, and special series and magazine articles and features in preparation for Advanced Journalism .

ADVANCED JOURNALISM

Number: 121100
Recommendation: Journalism I and Journalism teacher recommendation.
Credit: 1
Grade: 10-12

This class will assume responsibilities of the newspaper staff.

PUBLIC SPEAKING

Number: 139900
Recommendation: None
Credit: 1
Grade: 9-12

Students will learn to be effective and comfortable public speakers through the practice of Forensics and Debate, as well as persuasive and expository techniques. Students will be well versed in Lincoln-Douglas Debate, persuasive devices, and the art of interpreting a piece of literature. Through the class activities, all English and many history SOLs will be addressed. In order to be successful, students should be familiar with current events, able to provide evidence for an argument, and be eager to become more professional and fluent speakers.

CREATIVE WRITING

Number: 117100
Recommendation: None
Credit: 1
Grade: 11-12

Students will explore different modes of creative expression by studying a variety of models and by experimenting with various genres and styles. Active class participation, peer-editing, and frequent original works will be stressed along with other exercises, games, and prompts intended to explore/enhance the creative process. Students will discuss the publishing of works, and will be encouraged to submit their writings for publication. Provides a necessary groundwork for students interested in fiction writing, journalism, or marketing.

ENGLISH 12 CS

Number: 116010
Recommendation: English 11
Credit: 1
Grade: 12

Students will study a variety of materials of their choosing along with British literature and its historical context. Through reading and research students will create varied media products both independently and in small groups. Students will write in a variety of modes with an emphasis on persuasion, argument, and response to texts and research topics through discussion, writing and other activities. Class activities and experiences are designed to promote student collaboration, creativity, and critical thinking, as well as sharpen oral and written communication skills. Students will be required to produce a well-documented research paper or project along with a 8-20 minute oral presentation (SIRS).

ENGLISH AS SECOND LANGUAGE (ESL) I-IV

Number: 571000
Recommendation: English Language Program Identification
Credit: 1
Grade: 9-12

The ESL (English as a Second Language) class is designed to provide academic support to identified English Learners in accordance with the WIDA proficiency and screening assessments and state and federal requirements. Services for ESL students are based upon individual assessment scores, enrolled coursework, and diploma requirements. Instruction will be content-based and emphasize the language of reading, social studies, science, and mathematics across the four domains of reading, writing, listening, and speaking. Students work in a small group setting to improve their individual English proficiency levels and apply academic English skills to their content classwork.

Visual & Performing Arts

Visual Art Courses

GHS Course No.	Course Title	Credit	9	10	11	12	Recommendation
122000	Yearbook	1	x	x	x	x	Approved portfolio
912000	Art Foundations	1	x	x	x	x	None
913000	Drawing and Painting	1		x	x	x	Art Foundations
919700	Advanced Studio Art	1			x	x	3-D Design Crafts or Drawing & Painting
914900	Studio Art/Portfolio Advanced Placement*	1			x	x	At least one studio course
915300	Graphic Design	1		x	x	x	Art Foundations
915400	Advanced Digital Art	1			x	x	Graphic Design or Photography/Printmaking
916000	Three Dimensional Arts and Crafts	1		x	x	x	Art Foundations
917000	Art History	1		x	x	x	World History I
919000	Digital Photography & Printmaking	1		x	x	x	Art Foundations

*Students interested in Honors, Dual Enrollment or Advanced Placement classes should consult with their current teacher prior to requesting the course.

ART FOUNDATIONS

Number: 912000
Recommendation: None
Credit: 1
Grade: 9-12

During the first semester of Art Foundations, students will be taught basic drawing, visual skills and the elements and principles of design required for all studio art classes. During second semester, Art Foundations will be an exploratory course of different art media and techniques. Proficiency in artistic skills and creativity in design are developed. Media ranges from pencil, colored pencils, and markers to paint.

DRAWING AND PAINTING

Number: 913000
Recommendation: Art Foundations
Credit: 1
Grade: 10-12

In Drawing, students will develop advanced drawing techniques, using pencil, pen and ink, pastels and colored pencils. In Painting, acrylics and water colors will be explored. History and contemporary movements will be integrated within the curriculum. Students will provide their own paint, brushes, canvasses, drawing pencils, and sketchbook. *(Do not purchase equipment or supplies before attending class and speaking with the instructor.)*

ADVANCED STUDIO ART

Number: 919700
Recommendation: 3-D Design/Crafts or Drawing & Painting
Credit: 1
Grade: 11-12

Advanced Studio Art is a fast-paced course designed to prepare students to take AP Studio Portfolio, submit a college portfolio, and/or apply for Summer Governor's School for the Visual Arts. Students will expand their knowledge of either 3-D Design/Crafts or Drawing & Painting.

STUDIO ART/PORTFOLIO ADVANCED PLACEMENT*

Number: 914900
Recommendation: At least one studio course
Credit: 1
Grade: 11-12

This is a fast paced course designed for the serious art student who wishes to develop a portfolio or body of work in which they have already completed advanced course work. Students will work independently with course instructor's guidance. The student will receive summer assignments upon registration for the course. *Students enrolled in this course are recommended to take the AP Examination in May.*

GRAPHIC DESIGN

Number: 915300
Recommendation: Art Foundations
Credit: 1
Grade: 10-12

This course explores the techniques and materials of the Graphic Designer. In addition to other media, the student will use digital art software to design ads, logos, illustrations, package design, typography, and other projects. Discussion and evaluation of class projects and professional examples will aid in the understanding of strong design and sales appeal.

ADVANCED DIGITAL ART

Number: 915400
Recommendation: Graphic Design or Digital Photography/Printmaking
Credit: 1
Grade: 11-12

Advanced Digital Art will introduce advanced digital media topics such as digital camera manual setting features, dark room processing, computer art design, and how to create specific media for real world uses such as marketing and advertising. Students will review and expand their understanding of topics explored in Digital Photography and Printmaking or Graphic Design. In addition, students will explore traditional SLR cameras and experience photographic processing and printing. Students will also utilize computer art software and create products that relate to current, real world digital media trends.

THREE DIMENSIONAL DESIGN/CRAFTS

Number: 916000
Recommendation: Art Foundations
Credit: 1
Grade: 10-12

Students will study a variety of traditional craft areas as well as contemporary design and mediums. These areas may include hand built ceramics, plaster casting, weaving, silk painting, paper sculpture and bookmaking.

ART HISTORY

Number: 917000
Recommendation: World History I
Credit: 1
Grade: 10-12

Students will explore the history of art from prehistoric to contemporary times. Students will examine the cultural, geographic, historical and political contexts in which the artwork was completed. Students will be expected to identify artwork, periods and artworks of specific artists. This is a writing intensive, non-studio course.

DIGITAL PHOTOGRAPHY & PRINTMAKING

Number: 919000
Recommendation: Art Foundations
Credit: 1
Grade: 10-12

Digital Photography students will explore basic photographic issues, picture taking, composition, quality and manipulation of the image and the camera. Students need to supply their own digital camera. Some loaners may be available (Please see the instructor for more information.) In Printmaking, students explore monoprints, collagraph, block printing, dry point etching and stencils. Historical and contemporary movements will be integrated within both curriculums.

YEARBOOK

Number: 122000
Recommendation: By approved portfolio only
Credit: 1
Grade: 9-12

The objective of the Yearbook course is the successful on time, within budget, publication of the high school annual. Students will be exposed to state-of-the-art software and digital imaging for computer publishing. Writing and layout composition will be included.

Theater Courses

GHS Course No.	Course Title	Credit	9	10	11	12	Recommendation
141000	Theater I	1	x	x	x		None
142000	Theater II	1		x	x	x	Theater I
142300	Theater III	1			x	x	Theater II
142600	Theater IV	1				x	Theater III
143500	Technical Theater	1		x	x	x	Theater I

THEATER I

Number: 141000
Recommendation: None
Credit: 1
Grade: 9-11

Theatre I is designed as a basic survey of the theatre arts, serving as a foundation for those students who wish to begin a full, four-year study and as an enrichment for those students who wish merely to sample the area of study as a one-time elective. The composition of the course includes oral interpretation, mime, improvisation, movement, and short plays.

THEATER II

Number: 142000
Recommendation: Theater I
Credit: 1
Grade: 10-12

Theatre II is a studio course. Students are given intensive work in stage movement, vocal production, and character interpretation. Intimate productions are planned and performed by the students using excerpts or short works by established dramatists.

THEATER III

Number: 142300
Recommendation: Theater II
Credit: 1
Grade: 11-12

Theatre III concentrates on acting methods and styles. Character studies comprise the bulk of the research and practice done by the students. Accepted formulas such as "method" are studied, and their relative merits are weighed. In-class performances give students a chance to evaluate approaches to characterization.

THEATER IV

Number: 142600
Recommendation: Theater III
Credit: 1
Grade: 12

Theatre IV serves as a culmination effort for the theatre student. Intensive work in character study and movement allows the student to gather past work and study into some kind of final product of performance. It is during this course that students are given their first, real directional tasks. A series of in-class performances provide the laboratory for these students.

TECHNICAL THEATER

Number: 143500
Recommendation: Theater I
Credit: 1
Grade: 10-12

Technical Theatre gives the student not only the accepted practices and theories of the technical aspects of theatre production, but also hands-on experience by intensive lab sessions in areas including design, construction, painting, sound, and lighting. Students will be expected to help in the technical aspects of major productions of the Fine Arts Department. There is a \$65 fee for the purchase of a make-up kit.

Music Courses

GHS Course No.	Course Title	Credit	9	10	11	12	Recommendation
922500	Music Theory	1		x	x	x	Any chorus, band, guitar or private music instruction
	Music Theory, Adv Placement	1			x	x	
923300	Symphonic Band	1	x	x	x	x	Previous band experience
923400	Wind Ensemble	1	x	x	x	x	Director recommendation.
923410	Percussion Ensemble	1	x	x	x	x	Director recommendation.
925000	Jazz Ensemble	1	x	x	x	x	Director recommendation.
926000	Advanced Women's Chorus	1	x	x	x	x	By audition only
926010	Men's Chorus	1	x	x	x	x	Previous chorus experience
928000	Select Ensemble	1		x	x	x	By audition only
928510	Concert Choir	1		x	x	x	Previous chorus experience

MUSIC THEORY

Number: 922500
Recommendation: Any music class or private instruction
Credit: 1
Grade: 10-12

Music Theory I is designed for those interested in pursuing vocal, instrumental or general music or those with a strong desire to study music theory. The course provides instruction and information on the traditional elements of music including notation, pitch, meter and meter signatures, the keyboard, scales and key signatures. The course provides instruction and information on the traditional elements of music including principles of voice leading, part writing, triads and their inversions, cadences, seventh chords and some chromaticism.

MUSIC THEORY, ADVANCED PLACEMENT*

Number: 922501
Recommendation: Any music class or private instruction
Credit: 1
Grade: 11-12

The AP Music Theory course corresponds to one or two semesters of typical, introductory college music theory coursework that covers topics such as musicianship, theory, and musical materials and procedures. Musicianship skills, including dictation and listening skills, sight singing, and harmony, are an important part of the course. Through the course, students develop the ability to recognize, understand, and describe basic materials and processes of tonal music that are heard or presented in a score. Development of aural (listening) skills is a primary objective. Performance is also part of the curriculum through the practice of sight-singing. Students learn basic concepts and terminology by listening to and performing a wide variety of music. Notational skills, speed, and fluency with basic materials are emphasized. *Students enrolled in this course are recommended to take the AP Examination in May.*

SYMPHONIC BAND

Number: 923300
Recommendation: Previous band experience
Credit: 1
Grade: 9-12

Previous band/comparable instrumental music experience. All members perform with the Marching Dukes Field Show and parade groups. After school rehearsals and performances are REQUIRED including local, district, and state festivals and competitions. A high standard of performance is expected from members of the GHS band. Proper performance of scales, exercises and repertoire requires additional practice both at home and school.

WIND ENSEMBLE

Number: 923400
Recommendation: Director Recommendation
Credit: 1
Grade: 9-12

By audition only and recommendation of director. All members perform with the Marching Dukes Field Show and parade groups. *After school rehearsals and performances are REQUIRED including local, district, and state festivals and competitions.* Wind Ensemble members will rehearse and perform the Symphonic Band literature as well as more advanced music. Performance expectations are high at this level. Some students will be afforded the opportunity to conduct classes/rehearsals. Members are expected to become very proficient on their respective instrument, including meeting scale requirements as set by the Virginia Band and Orchestra Director's Association.

PERCUSSION ENSEMBLE

Number: 923410
Recommendation: Director Recommendation
Credit: 1
Grade: 9-12

All members perform with the Marching Dukes Field Show and parade groups. After school rehearsals and performances are required including local, district, and state festivals and competitions. This course is designed to give percussion students in-depth instruction on all percussion instruments used in concert and marching bands. Students are expected to become more proficient on instruments they have little or no experience playing. For example, students who have background on mallets will learn fundamentals of the snare drum. Snare players will learn to play mallet parts. Students will be able to perform any part whether it is timpani, mallets, snare, bass drum or auxiliary percussion. All percussionists are to register for this class unless told otherwise.

JAZZ ENSEMBLE

Number: 925000
Recommendation: Director Recommendation
Credit: 1
Grade: 9-12

Recommendation of director and co-register in Symphonic Band, Wind Ensemble or Percussion Ensemble is required. All members perform with the Marching Dukes Field Show and parade groups. After school rehearsals and performances are required including local, district, and state festivals and competitions. The jazz ensemble expects high standards of performance with instruments traditionally found in jazz groups of this nature. In addition to scale requirements found in the other performing groups, members will learn the basic elements of jazz and perform in small groups and individually.

ADVANCED WOMEN'S CHORUS

Number: 926000
Recommendation: By audition only
Credit: 1
Grade: 9-12

Advanced Women's Chorus is a choir for women seeking intermediate chorus experience with emphasis on major works choral literature, developing vocal technique, and music reading skills. The chorus requires a commitment to excellence and participation in an active performing schedule. Students will be required to participate in after-school rehearsals, various performances, festivals, competitions, and district/regional/state events. There is a \$15 activity fee and a \$35 choral booster fee required for this class.

MEN'S CHORUS

Number: 926010
Recommendation: Previous chorus experience
Credit: 1
Grade: 9-12

Men's Chorus I emphasizes developing skills essential to interpretation of the musical score, including sight reading and the study of various musical styles and cultures. Students who cannot match the sound of their singing voice to the sound of the piano will not be eligible for this class. Men's chorus is an intermediate level chorus class for which some musical knowledge, ability and/or experience is necessary. Students will be exposed to a wide variety of vocal literature and provided with opportunities to develop a lasting interest in vocal music. *They will be required to participate in at least two concerts with after school rehearsals.* There is a \$15 activity fee and a \$35 choral booster fee required for this class.

SELECT ENSEMBLE

Number: 928000
Recommendation: By audition only
Credit: 1
Grade: 10-12

Select Ensemble is for men and women seeking an advanced chorus experience with emphasis on performing and advanced vocal technique and music reading skills. The course requires a commitment to excellence and participation in an active performing schedule. Students will participate in after school rehearsals as well as various performances. Participation in festivals, competitions, and district, regional and state events is required. There is a \$15 activity fee and a \$35 choral booster fee required for this class.

CONCERT CHOIR

Number: 928510
Recommendation: Previous chorus experience
Credit: 1
Grade: 9-12

Concert Choir is for men and women seeking to develop skills essential to interpretation of the music score, including sight reading and the study of various musical styles and cultures. Students will be exposed to a wide variety of vocal literature and provided with opportunities to develop a lasting interest in vocal music. Students will be required to participate in after school rehearsals as well as various performances.

World Language

GHS Course No.	Course Title	Credit	9	10	11	12	Recommendation
511000	French I	1	x	x	x	x	None
512000	French II	1	x	x	x	x	French I
513000	French III	1		x	x	x	French II
514005	French IV Honors*	1			x	x	French III
517005	French V Advanced Placement*	1				x	French IV Honors
551000	Spanish I	1	x	x	x	x	None
552000	Spanish II	1	x	x	x	x	Spanish I
553000	Spanish III	1		x	x	x	Spanish II
554005	Spanish IV Honors*	1			x	x	Spanish III
557005	Spanish V Advanced Placement*	1				x	Spanish IV Honors

See page 58 for additional World Language options offered through Virtual Virginia.

*Students interested in Honors, Dual Enrollment or Advanced Placement classes should consult with their current teacher prior to requesting the course.

FRENCH I

Number: 511000
Recommendation: None
Credit: 1
Grade: 8-12

This is a beginning French course which introduces the four basic skills of a foreign language study: speaking, listening, reading and writing. This course also offers an introduction to French culture and customs in French speaking countries.

FRENCH II

Number: 512000
Recommendation: French I
Credit: 1
Grade: 9-12

French II is designed to build upon the foundation skills laid in French I. Difficulty of material increases, and the student is able to communicate in present, past, and future tenses. More cultural study is pursued at this level.

FRENCH III

Number: 513000
Recommendation: French II
Credit: 1
Grade: 10-12

In French III, French is used almost exclusively in the classroom as students continue to develop proficiency in the language. Communication skills and grammatical concepts are integrated. Students discuss literature, history, and contemporary events of French speaking areas.

FRENCH IV HONORS*

Number: 514005
Recommendation: French III
Credit: 1
Grade: 11-12

French IV is designed for complete interactive communication. The students comprehend written and spoken texts and produce compositions on a variety of topics. This course includes the study of history, literature, and contemporary issues. The students will start preparation for the Advanced Placement Test and the SAT II Test that will be completed in French V. It is designed to equal a French 200 course in college.

FRENCH V ADVANCED PLACEMENT*

Number: 517005
Recommendation: French IV Honors
Credit: 1
Grade: 12

French V AP is designed to increase the student's confidence in language ability and to perfect speaking and writing skills. The course continues the student's preparations for the SAT II and the AP Test. The student will read many genres of literature, and study art, music, French cuisine, and international business. The students will share their knowledge of French with the lower levels of French and the elementary and preschool students. Technology is a vital part of the learning process. *Students enrolled in this course are recommended to take the AP Examination in May.*

SPANISH I

Number: 551000
Recommendation: None
Credit: 1
Grade: 8-12

Spanish I focuses on the development of the students' communicative competence in Spanish and their understanding of the cultures of Spanish speaking countries. Students practice comprehension by reading, writing, listening and speaking the language in authentic situations.

SPANISH II

Number: 552000
Recommendation: Spanish I
Credit: 1
Grade: 9-12

The students in Spanish II continue to develop their proficiency in the three modes of communicative competence: interacting with other speakers of Spanish, understanding oral and written messages in Spanish, and making oral and written presentations in Spanish. They begin to show a greater level of accuracy when using basic language structures and comprehending more complex features of written and spoken Spanish.

SPANISH III

Number: 553000
Recommendation: Spanish II
Credit: 1
Grade: 10-12

Spanish III continues to develop the students' communicative skills. They communicate using more complex structure in Spanish on a variety of topics, moving from concrete to more abstract concepts. Emphasis continues to be placed on the use of Spanish in the class as students develop the ability to discuss topics related to historical and contemporary events and issues.

SPANISH IV HONORS*

Number: 554005
Recommendation: Spanish III
Credit: 1
Grade: 11-12

In Spanish IV Honors, the class will be taught in Spanish and the students will speak in the target language. Students will continue to develop their proficiency in the four communicative skills: listening, speaking, reading, and writing. Emphasis is placed on utilizing Spanish to engage in authentic communication with partners, groups, and the class. Students will continue to develop vocabulary and grammar and apply it in both oral and written presentations. Students will be able to exchange and support opinions in Spanish on a variety of topics related to contemporary, historical, and cultural events and issues. Students will begin to prepare for the Advanced Placement and SAT II Tests. This preparation will be completed in Spanish V AP.

SPANISH V ADVANCED PLACEMENT*

Number: 557005
Recommendation: Spanish IV Honors
Credit: 1
Grade: 12

In Spanish V AP, the class will be taught in Spanish and the students will speak in the target language. Students will continue to develop proficiency in the four communicative skills: listening, speaking, reading, and writing as they interact with a variety of authentic sources. Emphasis is placed on utilizing Spanish to engage in authentic communication with partners, groups, and the class. Students will develop a rich vocabulary and knowledge of fine points of grammar. Students will exchange and support opinions in Spanish on a variety of topics in order to develop a facility for oral communication. Students will engage in daily practice of the various sections of the Advanced Placement Test using materials as well as previously released tests. ***Students enrolled in this course are recommended to take the AP Examination in May.***

Health, Physical Education, and Driver Education

The *Physical Education* curriculum provides students with activities to develop organic strength, physical fitness, efficient body control and movement. The activities will give students skills necessary for lifetime fitness in individual and team sports. *Health Education's* goal is to develop in each student proper attitudes for disease prevention and control; use and effects of tobacco, alcohol, and drugs; awareness of the environment; and guidelines for safe and effective consumer health practices. *Driver Education's* purpose is to allow each student to develop safe driving skills and to understand the State Motor Vehicle Code so that each student can become a licensed driver. All PE classes require a \$17 uniform fee and \$3 locker fee.

GHS Course No.	Course Title	Credit	9	10	11	12	Recommendation
731000	Health/Physical Education 9	1	x	x	x	x	None
740000	Health / Physical Education 10	1		x	x	x	Health/Physical Education 9
701500	Driver's Education	1		x	x	x	Health/Physical Education 9
764000	Advanced Physical Education/Lifetime Fitness	1			x	x	Health/PE 9-10 and upperclassmen not participating in athletics
756000	Strength and Conditioning for Athletes	1	x	x	x	x	Member of an athletic team
765010	Strength and Conditioning	1			x	x	Physical Education I and II
766000	Sports Medicine/Advanced Athletic Training	1			x	x	Grade 11 or higher

HEALTH/PHYSICAL EDUCATION 9

Number: 731000
Recommendation: None
Credit: 1
Grade: 9-12

Health 9 consists of instruction in health to include topics of physical activity/nutrition, tobacco/alcohol and other drugs, diseases/disorders, injury prevention and environmental health and violence prevention. Physical Education 9 consists of physical fitness and conditioning, rhythmic activities/ dance, and team sports.

HEALTH/PHYSICAL EDUCATION 10

Number: 740000
Recommendation: Health/PE 9
Credit: 1
Grade: 10-12

Health 10 continues health topics including alcohol and other drugs, mental and emotional health. PE 10 consists of conditioning fitness, rhythmic activities, individual & team sports.

DRIVER'S EDUCATION

Number: 701500
Recommendation: Health/PE 9
Credit: 1
Grades: 10-12

The Driver's Education classroom course emphasizes traffic knowledge, Virginia law, and a proper attitude toward the use of motor vehicles.

ADVANCED PHYSICAL EDUCATION/LIFETIME FITNESS

Number: 764000
Recommendation: Health/PE 9-10 and upperclassmen not participating in athletics
Credit: 1
Grade: 11-12

Advanced PE will promote lifetime fitness skills that enable students to manage a healthy lifestyle and improved wellness into adulthood. Cardiovascular conditioning, muscular strength/endurance activities, and flexibility are emphasized for individual improvement. The course will model and promote life skills such as good decision-making and choosing an active lifestyle, in order to help students be more successful in assuming an active role in their personal health and overall well-being. This course is for upperclassmen who are not involved in athletics or on a GHS sports team.

STRENGTH AND CONDITIONING FOR ATHLETES

Number: 765000
Recommendation: Athletic Team Membership
Credit: 1
Grade: 9-12

This course will include sport specific conditioning and is designed to improve strength through the lifting of weights. The class includes instruction in the proper techniques of weight lifting, diet, footwork, agility, increasing speed and flexibility. Students must have the recommendation of their team coach; no exceptions.

STRENGTH AND CONDITIONING

Number: 765010
Recommendation: PE I & II
Credit: 1
Grade: 11-12

This course is designed as a conditioning course for a healthy lifestyle and improved strength through lifting weights. This is an excellent class for athletes and non-athletes.

SPORTS MEDICINE / ADVANCED ATHLETIC TRAINING

Number: 766000
Recommendation: Grade 11 or higher
Credit: 1
Grade: 11-12

Sports Medicine I is offered to students who are interested in furthering his or her education in or along the fields of Athletic Training. This course is useful for those students acting as managers of GHS athletic teams.

Advanced Athletic Training is offered to students who have taken and passed Sports Medicine I and that are interested in expanding their knowledge in the field of Athletic Training. The program will provide students with the skills to prepare for a possible degree in a medical field such as, athletic training, physical therapy, or orthopedic medicine. This course is useful for those students acting as managers of GHS athletic teams.

History and Social Sciences

GHS Course No.	Course Title	Credit	9	10	11	12	Recommendation
234100	World History I	1	x				None
234105	World History I Honors*	1	x				None
234200	World History II	1		x			Grade 10
238005	World History: Modern Advanced Placement*	1		x			World History I
236010	United States History	1			x		Grade 11
236020	American Studies United States History	1			x		Grade 11, co-enrolled in American Studies English 11
236055	United States History Dual Enrollment*	1			x		Grade 11 and RCC Placement Test
231905	United States History Advanced Placement*	1			x		Grade 11
244000	United States Government	1				x	Grade 12
244055	United States Government Dual Enrollment*	1				x	Grade 12 and RCC Placement Test
244505	United States Government Advanced Placement*	1				x	Grade 12
221205	Human Geography, Advanced Placement*	1		x	x	x	World History I; Grade 10 or higher
250000	Sociology	1			x	x	Grade 11 or higher
290000	Psychology	1			x	x	Grade 11 or higher
290255	Psychology Advanced Placement*	1			x	x	Strong language and writing skills
299601	The Second World War	1		x	x	x	Grade 10 or higher
299602	The American Civil War/The Cold War	1		x	x	x	Grade 10 or higher
299603	Native American Studies	1	x	x	x	x	None
299604	African American History	1	x	x	x	x	None
299605	Philosophy	1			x	x	Grade 11 or higher
299607	History of American Movies	1		x	x	x	Grade 10 or higher
299608	History Through Film	1		x	x	x	Grade 10 or higher

299610	History of Gloucester County, VA	1	x	x	x	x	None
299612	World Religions and Global Ethics	1			x	x	World History I and II
870200	Introduction to Criminal Justice	1			x	x	Grade 11 or higher

*Students interested in Honors, Dual Enrollment or Advanced Placement classes should consult with their current teacher prior to requesting the course.

WORLD HISTORY I (PREHISTORY—1500 AD)

Number: 234100
Recommendation: None
Credit: 1
Grade: 9-10

World History I (Prehistory to 1500 AD) explores the struggles and progress of mankind from the dawn of man through the Renaissance. It emphasizes the challenges to man and his triumphs through persistence, determination, and ingenuity. Students will examine the period and draw conclusions and connections. This course requires SOL testing.

WORLD HISTORY I HONORS* (PREHISTORY—1500 AD)

Number: 234105
Recommendation: None
Credit: 1
Grade: 9-10

World History I Honors is a celebration of man's achievements. Students are expected to delve into the past through in-depth independent research. They must compare & contrast, analyze data and present their findings. Student papers and presentations must be well-researched scholarly endeavors indicative of the students' abilities to creatively synthesize and develop their theses. This course affirms that we learn from the past to live in the present & to anticipate the future. This course requires SOL testing.

WORLD HISTORY II (1500 AD—PRESENT)

Number: 234200
Recommendation: Grade 10
Credit: 1
Grade: 10-12

World History II (1500 AD to Present) is an in-depth study of the history of the world from the Protestant Reformation through the Contemporary Era. This course encourages students to evaluate and reevaluate. Students will see a pattern in world events and examine the world they live in. This curriculum is in tandem with the VA Standards of Learning and should assure students' mastery of competencies. This course requires SOL testing. While elective courses are designed to foster student interest, it is important to remember that they retain an emphasis on academic development. *Please note that while World History II is an elective, it is a pre-requisite for a number of electives and honors classes.*

WORLD HISTORY: MODERN ADVANCED PLACEMENT*

Number: 238005
Recommendation: World History I
Credit: 1
Grade: 10

AP World History: Modern is designed to be the equivalent to a college world history course. In AP World History: Modern students investigate significant events, individuals, developments, and processes from approximately 1200 C.E. to the present. Students develop and use the same skills, practices, and methods employed by historians: analyzing primary and secondary sources; making historical comparisons; utilizing reasoning about contextualization, causation, and continuity and change over time; and developing historical arguments. ***Students enrolled in the course are recommended to take the AP Examination in May.***

UNITED STATES HISTORY

Number: 236010
Recommendation: Grade 11
Credit: 1
Grade: 11

US History reviews events of American History from European expansion and colonization of the New World to the Presidency of George W. Bush. Emphasis is placed on key periods of history such as the development of our constitutional form of government or the role of the U.S. as a worldwide power since 1945. The importance of our past and its influence and impact on society today is consistently emphasized. This course requires SOL testing.

AMERICAN STUDIES (UNITED STATES HISTORY & ENGLISH 11)

Number: 236060
Recommendation: Grade 11 and co-enrolled in American Studies English 11
Credit: 1
Grade: 11

The study of United States History and American Literature are natural partners for a joint investigation. The bridge created by jointly investigating literary works from each theme will promote a greater appreciation of both United States History and American Literature. Students will focus on reading and writing to increase their abilities to compare and contrast trends in American society and develop critical thinking skills. This focus will include a research paper where students reflect about the comparisons between the history and literature of the US. An emphasis will also be placed on persuasive writing, speaking, and debating. Students will read a variety of different genres from both primary and secondary sources. This course requires SOL testing English Reading & Writing and U.S. History.

UNITED STATES HISTORY DUAL ENROLLMENT*

Number: 236055
Recommendation: Grade 11 and RCC Placement Test
Credit: 1
Grade: 11

US History Dual Enrollment is a college course that offers students an opportunity to receive high school and college credit concurrently. Students will develop a comprehensive historical understanding of the political, economic, religious, social, intellectual, and artistic events of the United States. The student will be able to compare, contrast and analyze events and ideas as they relate to the United States. This course will also show the student how geography of the United States and the world has influenced the development of the United States. This course requires SOL testing.

UNITED STATES HISTORY ADVANCED PLACEMENT*

Number: 231905
Recommendation: Grade 11
Credit: 1
Grade: 11

US History AP will approach the study of American history in a manner similar to the US History course. Greater emphasis will be placed on work with historical documents and exposure to social and cultural factors that make America unique. The course will stress improvement in writing skills. Students will extensively prepare to take the AP Exam. Successful completion may exempt the student from taking an introductory US. History course in college. This course requires SOL testing. *Students enrolled in this course are recommended to take the AP Examination in May.*

UNITED STATES GOVERNMENT

Number: 244000
Recommendation: Grade 12
Credit: 1
Grade: 12

US Government emphasizes units on the Federal, State, and Local governments. Emphasis will be placed on the relationship between the branches and levels of government, on understanding how each level affects the individual, and on what the individual citizen can do to influence governmental decisions on each level. Students will consider the origin of our democratic institutions and study the Constitution of the United States, the State Constitution, and other historical documents. A major unit on the American free enterprise system will be presented along with a unit on comparative politics featuring the government structure and economy of the US and the Commonwealth of Independent States (formally U.S.S.R.).

UNITED STATES GOVERNMENT DUAL ENROLLMENT*

Number: 244055
Recommendation: Grade 12 and RCC Placement Test
Credit: 1
Grade: 12

Prospective students should be prepared for course assignments such as: analytical writings, independent readings, document analyses, research presentations, etc. US Government Dual Enrollment is a college course that offers students an opportunity to receive high school and college credit concurrently. The first semester emphasizes political theory and its connection to the basic organization and operation of the national government. The second semester is primarily concerned with specifics of governmental policy. It is the primary purpose of this course to make students educated participants in the American political system.

UNITED STATES GOVERNMENT ADVANCED PLACEMENT*

Number: 244505
Recommendation: Grade 12
Credit: 1
Grade: 12

US Government AP includes the objectives in the Standards of Learning for Government and includes development of understanding and awareness of government in action and practical operations of the United States and Virginia governments. The course also includes the development of understanding and awareness of international relations and a comparison of views. *Students enrolled in this course are recommended to take the AP Examination in May.*

HUMAN GEOGRAPHY ADVANCED PLACEMENT*

Number: 221205
Recommendation: Grade 10 or higher and World History I
Credit: 1
Grade: 10-12

The AP course in Human Geography will introduce students to the systematic study of patterns and processes that have shaped human understanding, use, and alteration of Earth's surface. Students will employ spatial concepts and landscape analysis to examine human social organization and its environmental consequences. They also will learn about the methods and tools geographers use in their science and practice. The APHG course is equivalent to an introductory college-level course. *Students enrolled in this course are recommended to participate in the AP examination in May.*

SOCIOLOGY

Number: 250000
Recommendation: None
Credit: 1
Grade: 11-12

Sociology explores the ways people interact with one another. Students will study relationships within groups, social institutions, the organization of societies, and vital issues and social problems of American society. Scientific procedures will be used to improve understanding of human relationships and societal problems.

PSYCHOLOGY

Number: 290000
Recommendation: None
Credit: 1
Grade: 11-12

Psychology explores the principles of psychology including behavior, values, emotional changes and self-concept that are the result of maturation and experience. Students will be introduced to many different fields of psychology and the theories of leaders in those fields. Emphasis will be placed on the three divisions of psychology: Learning Behavior, Sensation and Perception, and Abnormal Psychology. In the second half of the class students will study developmental psychology. Developmental psychology will study human psychological development from childhood to old age. Students will be introduced to the main psychologists in this field and will analyze their theories on development. This course will incorporate theories, development and behavior with the use of current events, readings, and the media.

PSYCHOLOGY ADVANCED PLACEMENT*

Number: 290255
Recommendation: Strong language & writing skills
Credit: 1
Grade: 11-12

Advanced Placement Psychology is based on the curriculum from the American Psychological Association (APA). Students will explore areas identified by both the American Psychology Association and the National Standards Board, specifically the five broad domains of scientific inquire, bio-psychological domain, developmental domain, cognitive and lastly variations in individual and group behaviors. Students will also explore current topics in the field of psychology. Academic performance will meet or exceed the rigorous requirements of an introductory level college survey course. Proficient language and writing skills are necessary. *Students enrolled in this course are recommended to take the AP Examination in May.*

THE SECOND WORLD WAR

Number: 299601
Recommendation: World History II
Credit: 1
Grade: 10-12

This course will be an intensive study of the causes, course and effects of the Second World War. Study will include the European and Pacific Theaters; land, naval, and aerial warfare; developments in weapons, technology, tactics; and studies of the diplomatic and social developments during the war. We will also study the home front, and the participation of women and minorities in the war effort. Enthusiastic reading of the textbook will be required. The course will include appropriate use of audio and visual resources, as well as study of actual artifacts from the war. ** Enrollment preference will be given to upper classmen and students who have passed or are currently enrolled in World History Two or US History.*

THE AMERICAN CIVIL WAR/THE COLD WAR

Number: 299602
Recommendation: None
Credit: 1
Grade: 10-12

The American Civil War will analyze the social, economic, and political causes and effects of the War Between the States. It will include battles, military tactics, weapons, medical technology, and an examination of how certain individuals provided leadership for both sides. Field trips to important battlefields will be an important part of this course. This course will be an academic college preparatory course, and extensive reading will be required. The Cold War will serve as an enrichment to U.S. History. This course will provide greater depth and detail of the international and domestic events from the 1930's to the current era. The Cold War includes a series of historical events that directly affect our society today. As students graduate and assume their place as citizens they need to have a solid background of these historical events in order to make informed choices

NATIVE AMERICAN STUDIES

Number: 299603
Recommendation: None
Credit: 1
Grade: 9-12

Native American Studies exposes students to key concepts in Native American history and culture from the Pre-Columbian era, through contrasting traditional life ways, through contemporary Native experiences. The initial focus on Pre-Columbian cultures will transition to studying the traditional life ways of the seven cultural regions of Native American Culture found in U.S. territory, and conclude with a study of the Native experience in contemporary Indian Country. The course incorporates primary and secondary sources as a means to enhance student understanding of varying Native experiences.

AFRICAN AMERICAN HISTORY

Number: 299604
Recommendation: None
Credit: 1
Grade: 9-12

This course will survey African American history from precolonial Africa through the present. Students will be introduced to key concepts in African American history from early beginnings in indigenous Africa through the transatlantic slave trade, the Civil War, Emancipation, Reconstruction, the Civil Rights era and into the present. The course, offered in a variety of learning models, will give students an opportunity to explore social events and processes, individuals and agency, documents and institutions; and to analyze past and present positions for future implications for African Americans.

PHILOSOPHY

Number: 299605
Recommendation: None
Credit: 1
Grade: 11-12

Philosophy covers the history and analysis of philosophical thought, starting with the Ancient Greeks (the Pre-Socratics, Socrates, Plato, Aristotle), and moving towards the present (covering the Hellenistic, Medieval, 17th, 18th, 19th and 20th centuries).

HISTORY OF AMERICAN MOVIES

Number: 299607
Recommendation: None
Credit: 1
Grade: 10-12

History of Film is a chronological/genre based course which studies classic films and their legacy. This course will start with a study of film technology and move into silent films, "talkies", and end in the 20th Century. Along the way, stops will be made to explore war movies, westerns, animated features, science fiction and independent films. Particular attention will be paid to film movements such as expressionism and the advent of the blockbuster film.

HISTORY THROUGH FILM

Number: 299608
Recommendation: None
Credit: 1
Grade: 10-12

History Through Film is a chronological look at the major events of world history and United States history. The course uses movies as a historical tool to study the events of the time period and examine the use of movies as a historical tool. The course starts with a look back at Rome with "Ben Hur" and goes through films during the Revolutionary War, Civil War, World War I, the Great Depression, World War II, the Cold War, and 20th Century America. The films are all connected to the Virginia SOL standards and the course is used to supplement the required social studies courses in grades 10—12.

HISTORY OF GLOUCESTER COUNTY, VIRGINIA

Number: 299610
Recommendation: None
Credit: 1
Grade: 9-12

This course will look at the history of Gloucester County from 1606 to the present. The course will focus on events of significance that took place in Gloucester and people of importance from or with ties to the area. The course will look at families who have been long time residents of the county. Field trips to important historical sites throughout the county will be incorporated. Guest speakers will be invited in to discuss topics. Genealogy searches of family history will also be incorporated.

WORLD RELIGIONS AND GLOBAL ETHICS

Number: 299612
Recommendation: World History I and II
Credit: 1
Grade: 11-12

World Religions and Global Ethics will analyze the historical, cultural, and theological foundations and development of major world religions, including (but not limited to): Christianity, Judaism, Islam, Hinduism, and Buddhism. Investigation of ethical concepts and religious issues also will be included. Students will develop a deeper understanding of the major world religions and the way in which different religions interpret and address specific issues. Students also will enhance their skills in historical analysis, writing, and research procedures.

INTRODUCTION TO CRIMINAL JUSTICE (DUAL)

Number: 870200
Recommendation: VPT Placement Test
Credit: 1
Grade: 11-12

Presents an overview of the United States criminal justice system; introduces the major system components—law enforcement, judiciary, and corrections.

Mathematics

GHS Course No.	Course Title	Credit	9	10	11	12	Recommendation
313000	Algebra I	1	x	x			None
313100	Algebra I, Part I	1	x				Completion of Math 8
313200	Algebra I, Part II	1		x			Completion of Algebra I, Part I
314300	Geometry	1	x	x	x	x	Algebra I
314305	Geometry Honors*	1	x	x	x	x	Algebra I
314400	Geometry Part I	1	x	x	x		Completion of Algebra I
314500	Geometry Part II	1		x	x	x	Completion of Geometry Part I
313400	Algebra Functions & Data Analysis	1		x	x	x	Geometry
313500	Algebra II	1	x	x	x	x	Geometry
313705	Algebra II/Trigonometry Honors*	1	x	x	x	x	Geometry
313600	Grade 12 Capstone Mathematics	1				x	AFDA or Algebra II
316000	Trigonometry and Statistics	1		x	x	x	Algebra II
316205	Math Analysis/Pre-Calculus Honors*	1		x	x	x	Algebra II/Trigonometry Honors or Trigonometry and Statistics
316255	Math Analysis/Pre-Calculus Dual*	1		x	x	x	Algebra II/Trigonometry Honors or Trigonometry and Statistics, RCC Placement Test
319905	Calculus Honors*	1			x	x	Math Analysis
317755	Calculus AB Advanced Placement*	1			x	x	Math Analysis/Pre-Calculus Honors
317756	Calculus BC Advanced Placement*	1			x	x	Calculus AB AP
319255	Statistics Advanced Placement*	1		x	x	x	Trigonometry and Statistics or Math Analysis

*Students interested in Honors, Dual Enrollment or Advanced Placement classes should consult with their current teacher prior to requesting the course.

ALGEBRA I

Number: 313000
Recommendation: None
Credit: 1
Grade: 9-10

Algebra I is the foundation for further studies in mathematics. This course will focus on the role of Algebra as a tool for describing and representing patterns and relationships. Algebra I includes the study of our number system and its properties, data representation, functions, solving equations and inequalities. This course continues with solving systems of equations and inequalities, and basic operations with polynomials, exponent laws, and rational expressions. A graphing calculator is required. The use of graphing calculators as the primary source of investigation will be an integral part of this course. This course requires SOL testing.

ALGEBRA I, PART I

Number: 313100
Recommendation: Mathematics (Grade 8)
Credit: 1 (see footnote p. 50)
Grade: 9

Algebra I Part I covers the first half of the Algebra I curriculum. Algebra I Part I includes the study of our number system and its properties, data representation, functions, solving equations and inequalities. A graphing calculator is required. The use of graphing calculators will be an integral part of this course. Upon successful completion of Algebra I Part I, students will be enrolled in Algebra I Part II.

* Students will receive one (1) elective credit for Algebra I Part I unless found eligible for credit accommodations for Students With Disabilities (IDEA and 504) as established by Virginia law or regulation.

ALGEBRA I, PART II

Number: 313200
Recommendation: Mathematics (Grade 8)
Credit: 1 (see footnote p. 50)
Grade: 9

Algebra I Part II covers the second half of the Algebra I curriculum and continues the study of our number system and its properties, data representation, functions, solving equations and inequalities. A graphing calculator is required. The use of graphing calculators will be an integral part of this course.

GEOMETRY

Number: 314300
Recommendation: Algebra I
Credit: 1
Grade: 9-11

Geometry emphasizes practical application of geometric principles including basic terminology, parallel lines, informal reasoning, triangles, introduction of trigonometry, plane figures, circles, and volume and surface area. A graphing calculator is required. This course requires SOL Testing.

GEOMETRY, PART I

Number: 314400
Recommendation: Algebra I
Credit: 1 (see footnote p. 50)
Grade: 9-12

Geometry, Part I covers the first half of the Geometry curriculum and emphasizes practical application of geometric principles including basic terminology, parallel lines, informal reasoning, triangles, introduction of trigonometry, plane figures, circles, and volume and surface area. A graphing calculator is required.

GEOMETRY, PART II

Number: 314500
Recommendation: Geometry, Part I
Credit: 1 (see footnote p. 50)
Grade: 9-12

Geometry, Part II covers the second half of the Geometry curriculum and emphasizes practical application of geometric principles including basic terminology, parallel lines, informal reasoning, triangles, introduction of trigonometry, plane figures, circles, and volume and surface area. A graphing calculator is required. This course requires SOL testing.

GEOMETRY HONORS*

Number: 314305
Recommendation: Algebra I
Credit: 1
Grade: 9-11

Geometry Honors is designed to develop logical and analytical thinking skills, inductive and deductive reasoning, and provide a solid base of geometrical concepts needed for subsequent advanced math and science courses. Students are required to master all the objectives of the regular geometry course plus more in-depth applications, more formal geometric proofs, and independent discovery projects. A graphing calculator is required. This course is strongly recommended for students planning to enroll in Algebra II Honors, Math Analysis Honors, and Calculus. This course requires SOL testing.

ALGEBRA, FUNCTIONS AND DATA ANALYSIS

Number: 313400
Recommendation: Geometry
Credit: 1
Grade: 10-12

Within the context of mathematical modeling and data analysis, students will study functions and their behaviors, systems of inequalities, probability, experimental design and implementation, and analysis of data. Data will be generated by practical applications arising from science, business, and finance. Students will solve problems that require the formulation of linear, quadratic, exponential, or logarithmic equations or a system of equations. Through the investigation of mathematical models and interpretation/analysis of data from real life situations, students will strengthen conceptual understandings in mathematics and further develop connections between algebra and statistics. Students should use the language and symbols of mathematics in representations and communication throughout the course. Standards include a transformational approach to graphing functions and writing equations when given the graph of the equation, which builds a strong connection between algebraic and graphic representations of functions. The infusion of technology (graphing calculator and/or computer software) in this course will assist in modeling and investigating functions and data analysis. **NOTE: This course counts toward graduation requirements in math; however, this course may not be taken for credit if a student already has earned a credit for Algebra II.**

ALGEBRA II

Number: 313500
Recommendation: Geometry
Credit: 1
Grade: 9-12

Algebra II is a course of study that extends and broadens the concepts introduced in Algebra I, including linear, quadratic, exponential, and logarithmic functions. This course is offered to help prepare the students for further study in mathematics. Graphing calculators are used extensively and are required for the course. This course requires SOL testing.

ALGEBRA II/TRIGONOMETRY HONORS*

Number: 313705
Recommendation: Geometry
Credit: 1
Grade: 9-12

Algebra II Honors is an advanced Algebra II course for students who are mathematically talented, motivated, and intending to pursue a career in mathematics, science, engineering, or a similar field. The students are required to master all the objectives of the regular Algebra II course which include linear, quadratic, polynomial, exponential and logarithmic functions. In addition, the students will extend and broaden their knowledge of Geometry Honors integrated with trigonometric functions, polar coordinates, and conic sections. Selected pre-calculus topics will also be presented. Problem solving skills will be emphasized, mastery of technology demonstrated, and projects related to the class objectives required. This course is strongly recommended for students planning to enroll in Math Analysis, Statistics, and Calculus. A graphing calculator is required. This course requires SOL testing.

GRADE 12 CAPSTONE MATHEMATICS

Number: 313600
Recommendation: AFDA or Algebra II; students seeking an Advanced Studies Diploma must also take Algebra II
Credit: 1
Grade: 12

Capstone Mathematics applies algebraic, geometric, and statistical concepts and the relationships among them to solve problems, model relations, and make decisions using data and situations within and outside of mathematics. It integrates and applies inductive and deductive reasoning skills to make, test, and evaluate mathematical statements and will use logical reasoning to analyze an argument and determine whether conclusions are valid. Other math topics will be addressed to prepare students for college-level mathematics.

TRIGONOMETRY AND STATISTICS

Number: 316000
Recommendation: Algebra II
Credit: 1
Grade: 10-12

Trigonometry and Statistics provides students with an opportunity to extend and broaden their knowledge of Algebra II concepts. The first half of the course includes solving trigonometric equations, graphing trigonometric functions, and applying trigonometric concepts to real world applications. The second half of the course covers one- and two-variable descriptions, data collection, probability and inferences about proportions and means, and how to utilize data to make predictions and inferences about the real world. A graphing calculator is required. **Note: Students who have earned a credit for Math Analysis will not receive credit for Trigonometry and Statistics following Analysis.**

MATH ANALYSIS/PRE-CALCULUS HONORS*

Number: 316205
Recommendation: Algebra II/Trigonometry Honors or Trigonometry/Functions
Credit: 1
Grade: 10-12

Math Analysis Honors is a fast paced advanced math course for students who are mathematically talented, motivated, and intending to pursue a career in mathematics, science, engineering, or a similar field. This course applies objectives mastered in Algebra I and II, Geometry, and Trigonometry to advanced mathematical topics. These topics include the study of functions, trigonometry and trigonometric proofs, the study of conic sections, algebra of vectors in two and three dimension, sequences and series, proofs by induction, parametric graph, and polar graphs. Additionally, the idea of a "limit" will be introduced. This course is a prerequisite for Calculus. A graphing calculator is required.

MATH ANALYSIS/PRE-CALCULUS DUAL*

Number: 316255
Recommendation: Algebra II/Trigonometry Honors or Trigonometry/Functions
Credit: 1
Grade: 10-12

Math Analysis Dual is a rigorous college math course that offers students, who are mathematically talented, motivated, and intending to pursue a career in mathematics, science, engineering, or a similar field, an opportunity to receive high school and college credit concurrently. This course applies objectives mastered in Algebra I and II, Geometry, and Trigonometry to advanced mathematical topics. These topics include the study of functions, trigonometry and trigonometric proofs, the study of conic sections, algebra of vectors in two and three dimension, sequences and series, proofs by induction, parametric graph, and polar graphs. Additionally, the idea of a "limit" will be introduced. This course is a prerequisite for Calculus. A graphing calculator is required.

CALCULUS HONORS*

Number: 319905
Recommendation: Math Analysis/Pre-Calculus Honors
Credit: 1
Grade: 11-12

Calculus Honors provides student with a rigorous course in Calculus with in-depth instruction in basic concepts. The course is designed for those students who do not intend to participate in the Advanced Placement Examination. Integrating many of the concepts and procedures from Algebra, Geometry and Trigonometry, the course will focus its first half on functions, limits and differential calculus with an emphasis on real world problems in the area of related rates, optimization and motion; while the second half of the course will focus on integral Calculus with applications that include calculations of areas enclosed by the graphs of functions, volumes of shapes defined by functions, and quantities by integrating derivative functions.

CALCULUS AB ADVANCED PLACEMENT *

Number: 317755
Recommendation: Math Analysis/Pre-Calculus Honors
Credit: 1
Grade: 11-12

Calculus AB AP is designed by the College Board for students who wish to pursue college level studies while still in high school. This course includes a study of differential and integral calculus. Applications are in the context of polynomial, parametric, trigonometric, logarithmic, and exponential functions. Special topics include optimization, curve sketching, related rates, slope fields, accumulation function. Students will use graphing calculators to support their work and facilitate explorations and modeling of the applications studied. A graphing calculator is required. The TI-89 Titanium is recommended. Some work will require the use of a graphing calculator; other work will be done without the use of any calculator. ***Students enrolled in this course are recommended to take the AP Examination in May.***

CALCULUS BC ADVANCED PLACEMENT *

Number: 317756
Recommendation: Calculus AB Advanced Placement
Credit: 1
Grade: 12

Calculus BC AP is designed by the College Board for students who wish to continue their study of college Calculus while still in high school. This course is an extension of the study of differential and integral calculus begun in Calculus AB AP. The techniques include partial fractions, Taylor Polynomials, infinite sequences and the series that define functions, trigonometric substitutions, tonic functions, slope fields, differential equations, and extensions in modeling of applications. Students will use graphing calculators to support their work and facilitate explorations and modeling of the applications studied. A graphing calculator is required. The TI-89 Titanium is recommended. Some work will require the use of a graphing calculator; other work will be done without the use of any calculator. *Students enrolled in this course are recommended to take the AP Examination in May.*

STATISTICS ADVANCED PLACEMENT*

Number: 319255
Recommendation: Algebra II
Credit: 1
Grade: 10-12

Math Statistics AP is designed by the College Board for students who wish to pursue college level studies while still in high school. The topics covered include analysis of patterns, planned data collection, survey design, and experimentation; probability; the normal, binomial, and geometric distributions; statistical inference using confidence intervals and hypothesis tests; and the analysis of possible errors in inference. Students will use graphing calculators to support their work and facilitate explorations and modeling of the applications studied. A graphing calculator is required. Students will use computer software to analyze data, and perform inferential analysis. Students will be evaluated by the College Board expectation for balanced sound statistical reasoning and clarity of communication in both oral and written formats. *Students enrolled in this course are recommended to take the AP Examination in May.*

Footnote regarding Algebra Parts I-II and Geometry Parts I-II: The Board of Education's Guidelines on Credit Accommodations allow students with disabilities who are eligible for credit accommodations in mathematics to use each part of Algebra I, Parts I and II, and Geometry, Parts I and II, to earn a standard credit toward the three mathematics credits required for the Standard Diploma only. A student with disabilities who chooses to earn standard credits by taking both Algebra I and Geometry in two parts must complete *both* parts of both courses to meet the minimum course requirements, and would earn three standard credits in mathematics plus one additional elective credit. Two-part courses may also be combined with full-year courses in other Board-approved mathematics courses to meet the requirements for students with disabilities.

ALGEBRA FOUNDATIONS

Number: 319900
Recommendation: None (placement from middle school)
Credit: 1 elective credit
Grade: 9

The Algebra Foundations course provides students additional instruction and time to acquire skills and conceptual understanding necessary for success in Algebra I. The curriculum reviews, extends, and builds upon concepts and skills learned in previous grades in order to prepare students for more abstract concepts in Algebra I. Topics include computation with rational numbers, problem-solving with proportional reasoning, solving multistep equations and inequalities, and graphing linear functions. Students earn an elective credit for successful completion of Algebra Foundations.

Science

The science department at GHS believes that all students should have a foundation of the fundamental science concepts and principles in both the biological and physical sciences. Students need at least three science credits from two disciplines to graduate, and student seeking an Advanced Studies Diploma need four science credits from three disciplines. The disciplines are as follows:

Biology

Biology I
 Biology II Dual or AP
 Anatomy & Physiology
 Ecology Dual
 Environmental Science AP VV

Earth Science

Earth Science
 Oceanography
 Astronomy
 Environmental Science

Chemistry

Chemistry I
 Chemistry II AP

Physics

Physics I
 Physics I AP

GHS Course No.	Course Title	Credit	9	10	11	12	Recommendation
461000	Environmental Science	1	x				None
461005	Environmental Science Honors*	1	x				None
421000	Earth Science	1			x	x	2 laboratory sciences
425000	Oceanography	1			x	x	2 laboratory sciences
426000	Astronomy	1			x	x	2 laboratory sciences
431000	Biology I	1		x			Grade 10
431005	Biology I Honors*	1	x	x			Grade 10 For Grade 9, see course description below
432055	Biology II Dual Enrollment*	1			x	x	Biology I, Chemistry I and RCC Placement Test
433000	Anatomy & Physiology	1			x	x	2 laboratory sciences
437005	Biology II Advanced Placement & Lab*	2			x	x	Biology I and Chemistry I
441000	Chemistry I	1	**	x	x	x	Biology and Algebra I
441005	Chemistry I Honors*	1		x	x	x	Biology and Algebra I
447005	Chemistry II Advanced Placement & Lab*	2			x	x	Chemistry I
451000	Physics I	1		x	x	x	Biology and co-enrolled Algebra II
457005	Physics Advanced Placement*	1			x	x	Physics and Algebra II
424055	Geology Dual Enrollment*	1			x	x	Environmental or Earth Science, Chemistry, RCC Placement Test
434055	Ecology Dual Enrollment*	1			x	x	2 laboratory sciences and RCC Placement Test

*Students interested in Honors, Dual Enrollment or Advanced Placement classes should consult with their current teacher prior to requesting the course.

ENVIRONMENTAL SCIENCE

Number: 461000
Recommendation: None
Credit: 1
Grade: 9

The Environmental Science course is an introductory course designed to prepare students for biology and chemistry through which students will focus on the scientific principles, concepts, and methodologies required to understand the interrelationships of the natural world. Students will identify and analyze natural and human-made environmental problems, evaluate the relative risks associated with these problems, and examine alternative solutions for resolving or preventing them.

ENVIRONMENTAL SCIENCE HONORS*

Number: 461005
Recommendation: None
Credit: 1
Grade: 9

The Honors Environmental Science course is a rigorous preparation for biology and chemistry that focuses on the scientific principles, concepts, and methodologies required to understand the interrelationships of the natural world. Students will identify and analyze natural and human-made environmental problems, evaluate the relative risks associated with these problems, and examine alternative solutions for resolving or preventing them. Students will be required to maintain a portfolio.

EARTH SCIENCE

Number: 421000
Recommendation: 2 laboratory sciences
Credit: 1
Grade: 11-12

Earth Science is the study of the planet Earth and its place in space. This course is designed for students curious about the world around them and the planet in which they live. Students will study topics such as oceans, volcanoes, earthquakes, the solar system, and the universe beyond. Earth Science stresses the value of the earth's natural resources and the need to conserve them so that students will be able to make educated and informed decisions as adults. This comprehensive course introduces the student to the role of Earth Science in research, technology, and modern life. This course requires SOL testing.

OCEANOGRAPHY

Number: 425000
Recommendation: 2 laboratory sciences
Credit: 1
Grade: 11-12

Oceanography is an in-depth study of the physical and biological factors of the marine environment and man's interaction with this environment. This course will cover such topics as the geology of the ocean basins, marine chemistry, waves, tides, ocean currents, living organisms in the environment and marine ecology, and man's interaction and policies dealing with oceans. The Chesapeake Bay will be studied in depth. Activities will include laboratory investigations, library research, and field experiences.

ASTRONOMY

Number: 426000
Recommendation: 2 laboratory sciences
Credit: 1
Grade: 11-12

This course is for students wishing to expand their knowledge of our place in the universe. The underlying principles of earth and physical science will be integrated in this study of the universe. Emphasis will be placed on Earth's place in the Solar System and the relationship between objects in space. Students will use scientific reasoning, class debates and discussions of current issues, and technology for research.

BIOLOGY I

Number: 431000
Recommendation: Grade 10
Credit: 1
Grade: 10-12

Biology I is the study of life. Organisms are studied based on the kingdom to which they belong from the cellular level to communities. Topics to be studied include cells, plants, genetics, microorganisms, animals with and without backbones, and ecology. The study will include laboratory investigations, discussions, library research, field experiences, and projects. This course requires SOL testing.

BIOLOGY I HONORS*

Number: 431005
Recommendation: Grade 10; Grade 9 students interested in a Governor's School will take Biology I Honors and Environmental Science Honors as paired courses in the 9th grade year
Credit: 1
Grade: 9-12

Biology I honors is a laboratory oriented study of life covering a broader range of topics than Biology I. It utilizes the experimental design in a student designed scientific research project that is completed during the first semester. The course emphasizes scientific investigation, critical thinking and process skills in lab reports, essays, and authentic research. Students selecting this course should be goal oriented, self-disciplined, capable of doing independent study and committed to making the maximum effort that the course requires. The independent research project and accompanying paper, as well as participation in the local STEM fair is a requirement of the course. The course requires SOL testing.

BIOLOGY II DUAL ENROLLMENT*

Number: 432055
Recommendation: Biology I, Chemistry I & RCC Placement Test
Credit: 1
Grade: 11-12

Biology II builds upon acquired knowledge from Biology I and Chemistry I. The course places emphasis on those topic areas that students will encounter in college biology such as biochemistry, cytology, embryology, genetics, and human physiology. Students are expected to do outside readings and write abstracts in addition to their course work. Appropriate laboratory investigations, classroom discussions, field trips and/or guest speakers will complete the course.

ANATOMY AND PHYSIOLOGY

Number: 433000
Recommendation: 2 laboratory sciences
Credit: 1
Grade: 11-12

The Anatomy and Physiology course is designed to provide an opportunity for the student to gain an understanding of the normal structure and function of the human body. The course begins with an introduction to physical laws and chemical properties, and then proceeds in organization from cells to tissues, organs, and systems of the normal human body. Principles of wellness practices for systems are included.

BIOLOGY II ADVANCED PLACEMENT & LAB*

Number: 437005
Recommendation: Biology I and Chemistry I
Credit: 2
Grade: 11-12

Biology II AP is a fast-paced learning environment that provides students with a college-level introductory biology course. Appropriate laboratory experiences will stress the results, and analysis-discussion is emphasized. Additional required and supplemental readings will be coordinated with the topics studied. This required lab component includes 12 AP biology labs that are experimental and quantitative in nature. Each lab requires 90 minutes to perform in addition to required pre- and post-lab periods. The lab component includes a literature review of current biotechnology or bioethical concerns. The AP Biology Exam each year includes a number of questions pertaining to topics and objectives of the 12 AP biology laboratory studies, strengthening the need for students' thorough understanding of these procedures. *Students enrolled in this course are recommended to take the AP Examination in May.*

CHEMISTRY I

Number: 441000
Recommendation: Biology and Algebra I
Credit: 1
Grade: 10-12

This course is designed to provide students with a detailed understanding of the interactions of matter and energy and emphasizes the qualitative and quantitative study of substances and the changes that occur in them. These interactions are investigated through laboratory techniques, manipulation of chemical quantities, and problem-solving applications. Students study the composition of matter, including physical, chemical and nuclear reactions of common elements, atomic structure, chemical bonding and theories, and are expected to develop skills in problem solving with an emphasis on mathematical applications and safe laboratory techniques. Scientific methodology is employed in experimental and analytical investigations and concepts will be illustrated with practical applications. Technology including graphing calculators and computers is employed where feasible. Students will understand the use and safety precautions with chemicals and equipment and will be encouraged to share their ideas, use the language of chemistry, discuss problem-solving techniques, and communicate effectively. This course requires SOL testing. ***9th Graders with special permission can take Chemistry concurrently with Biology Honors.*

CHEMISTRY I HONORS*

Number: 441005
Recommendation: Biology and Algebra I
Credit: 1
Grade: 10-12

Students enrolled in Honors Chemistry I study the composition of matter, including physical, chemical and nuclear reactions of common elements, atomic structure, chemical bonding and theories. Students are expected to develop skills in problem solving, with an emphasis on mathematical applications and safe laboratory techniques. The chemistry standards are designed to provide students with a detailed understanding of the interaction of matter and energy. Honors chemistry places emphasis on laboratory exploration with strong emphasis in the correlation of the lab exercises with chemistry theory. Problem solving both in the laboratory and through examples will be emphasized in the class. Effective writing skills are critical for success in this class. Technology, including graphing calculators and computers, will be employed where feasible. This course requires SOL testing. Each student must complete a STEM fair project as part of this course.

CHEMISTRY II ADVANCED PLACEMENT & LAB*

Number: 447005
Recommendation: Chemistry
Credit: 2
Grade: 11-12

The course is designed to be equivalent of the general chemistry course typical of the first college year. Students will gain rich understanding of fundamentals and a competence in dealing with chemical problems and the course will contribute to the development of the students' ability to think clearly and to express ideas orally and in writing with clarity and logic. College general chemistry differs qualitatively from the Chemistry AP Lab course in the textbook used, topics covered, and emphasis on chemical calculations and the mathematical formation of principles. Quantitative differences appear in the number of topics treated, time spent on the course by students, and the nature and variety of laboratory experiments. Chemistry II AP includes a minimum 20 AP chemistry labs that are both qualitative and quantitative in nature. The lab component includes chemistry concept reviews that relate the activities completed in lab to the content in the AP chemistry curriculum. The AP exam each year includes a number of questions pertaining to topics and objectives of the Chemistry AP Lab studies, strengthening the need for students' thorough understanding of these procedures. *Students enrolled in this course are recommended to take the AP Examination in May.*

PHYSICS I

Number: 451000
Recommendation: Biology and co-enrolled Algebra II
Credit: 1
Grade: 10-12

This course provides systematic introduction to the main principles of physics and emphasizes the development of conceptual understanding and problem-solving ability using Algebra. Topics include: mechanics, wave theory, sound optics, electricity, and magnetism.

PHYSICS ADVANCED PLACEMENT*

Number: 457005
Recommendation: Physics and Algebra II
Credit: 1
Grade: 11-12

Physics AP will follow an introductory level physics course and is intended to provide the necessary basis to achieve advanced college placement. Calculus will be used as needed, based on the expectation that only a modest effort will be required to elucidate those math techniques. The two major classical physics disciplines will be treated and topics from thermal physics, electromagnetic radiation, optics, and wave motion emphasized more thoroughly than in Physics. Selected modern physics will be included. *Students enrolled in this course are recommended to take the AP Physics I examination in May.*

GEOLOGY DUAL ENROLLMENT*

Number: 424055
Recommendation: Environmental or Earth Science, Chemistry, RCC Placement Test
Credit: 1
Grade: 11-12

The course is designed to be the equivalent of the general physical geology course typical of the first college year. Students will gain rich understanding of composition and structure of the earth and processes and forces that help shape it. Students will investigate the formation of minerals and rocks, weathering, erosion, earthquakes, volcanoes, and crustal deformation.

ECOLOGY DUAL ENROLLMENT*

Number: 434055
Recommendation: Two laboratory sciences & RCC Placement Test
Credit: 1
Grade: 11-12

This course draws on political and social sciences and the impact that these areas have on the environment. The first semester includes studies in the interrelationships between organisms and their natural and cultural environments with emphasis on populations, communities, and ecosystems using mathematical models, graphing calculators, and computer spreadsheets. The second semester incorporates aquatic and freshwater studies with emphasis on Virginia and the Chesapeake Bay, and the concepts mastered in the first semester will be applied to these areas. Global marine studies are also stressed. Emphasis is also placed on laws and case studies that affect the environment and ethical issues are discussed. The successful student will have a strong background in both Math and Science.

Specialized Educational Services

The Special Education Department at Gloucester High School is dedicated to ensuring multiple levels of service for students with disabilities. All students with disabilities are provided with a free appropriate public education. A continuum of instructional alternatives is provided within the least restrictive environment to ensure that each child has the opportunity to be successful. GHS offers special education classes (such as English, Mathematics, Science and Social Studies) and general education classroom instruction with special education assistance and/or modifications.

High school special education students are afforded the opportunity to receive a Standard Diploma, Advanced Studies Diploma, Modified Standard Diploma (*see NOTE below), Special Diploma, or Certificate of Completion. All secondary special education programs are designed to prepare the students to function at their highest academic and vocational potential. All programs share the common goal of preparing the students to lead a productive and independent adult life.

* NOTE: The Modified Standard Diploma will not be an option for students with disabilities who enter the ninth grade for the first time after 2012-2013. Beginning with students entering ninth grade for the first time in 2013-2014, credit accommodations will be provided to allow students with disabilities who previously would have pursued a Modified Standard Diploma to earn a Standard Diploma. Guidelines for credit accommodations will be issued by the Board of Education.

In order to be enrolled in any Special Education courses, students must be found eligible for special education services and must have a current Individualized Education Plan (IEP) in place. Together with their case manager, parent, and school counselor, the following elective courses may be selected for students with disabilities.

GHS Course No.	Course Title	Credit	9	10	11	12	Prerequisite
786560	Practical English	1	x	x	x	x	Special Education Eligibility and current IEP
786540	Practical Math	1	x	x	x	x	Special Education Eligibility and current IEP
786570	Practical Science	1	x	x	x	x	Special Education Eligibility and current IEP
786520	Practical History/Social Science	1	x	x	x	x	Special Education Eligibility and current IEP

PRACTICAL ENGLISH

Number: 786560
Recommendation: Special Education Eligibility and Current IEP
Credit: 1
Grade: 9-12

This individualized instructional course emphasizes basic reading, listening, speaking, spelling, vocabulary, grammar, and writing as outlined in the Individualized Education Plan (IEP). This course does not satisfy the credit-bearing requirements for a Modified, Standard, or Advanced diploma.

PRACTICAL MATH

Number: 786540
Recommendation: Special Education Eligibility and Current IEP
Credit: 1
Grade: 9-12

This individualized instructional course emphasizes mathematics reasoning and calculations skills introduced/mastered in the lower grades and as outlined in the Individualized Education Plan (IEP). This course does not satisfy the credit-bearing requirements for a Modified, Standard, or Advanced diploma.

PRACTICAL SCIENCE

Number: 786570
Recommendation: Special Education Eligibility and Current IEP
Credit: 1
Grade: 9-12

This individualized instructional course introduces/enhances practical science knowledge and skills as outlined in the Individualized Education Plan (IEP). This course does not satisfy the credit-bearing requirements for a Modified, Standard, or Advanced diploma.

PRACTICAL HISTORY/SOCIAL SCIENCE

Number: 786520
Recommendation: Special Education Eligibility and Current IEP
Credit: 1
Grade: 9-12

This individualized instructional course encompasses the major content components of history/social science and stresses citizenship and the awareness needed for adult functioning as outlined in the Individualized Education Plan (IEP). This course does not satisfy the credit-bearing requirements for a Modified, Standard, or Advanced diploma.

GHS Course No.	Course Title	Credit	9	10	11	12	Other Information
770001	Adaptive Health and Physical Education	1	x	x	x	x	Special Education Eligibility and current IEP
770003	Adaptive Art	1	x	x	x	x	Special Education Eligibility and current IEP
907600	Career Exploration	1	x	x	x	x	Special Education Eligibility and current IEP
908300	Employability Skills	1			x	x	Special Education Eligibility and current IEP
980400	Workplace Experience	1	x	x	x	x	Special Education Eligibility and current IEP
786550	Resource & Academic Support	1	x	x	x	x	Special Education Eligibility and current IEP
781000	Independent Living	1	x	x	x	x	Special Education Eligibility and current IEP
789601	Life Skills	1	x	x	x	x	Special Education Eligibility and current IEP

ADAPTIVE HEALTH AND PHYSICAL EDUCATION

Number: 770001
Prerequisite: Special Educational Eligibility & Current IEP
Credit: 1
Grade: 9-12

Students participate in a wide variety of sport and fitness related activities. Each activity is modified to fit the individual student's ability. This course also teaches the basics of living a healthy lifestyle. This course covers the following topics: mental and emotional health, personal health, family life, nutrition, preventing and controlling diseases and disorders, use and misuse of substances, injury preventing and safety promotion, and health & society.

ADAPTIVE ART

Number: 770003
Prerequisite: Special Educational Eligibility & Current IEP
Credit: 1
Grade: 9-12

This course explores a variety of hands-on art projects and techniques. Each activity is modified to fit the individual student's ability.

CAREER EXPLORATION

Number: 907600
Prerequisite: Special Educational Eligibility & Current IEP
Credit: 1
Grade: 9-12

Career Exploration helps students identify and evaluate personal goals, priorities, aptitudes, and interests with the goal of helping students make informed career decisions. The course exposes students to various sources of information on career and training options and also may assist them in developing job search and employability skills.

EMPLOYABILITY SKILLS

Number: 908300
Prerequisite: Special Educational Eligibility & Current IEP
Credit: 1
Grade: 11-12

This course helps students match interests and aptitudes to career options through effective use of employment information, acquisition and improvement of job-seeking and interview skills, composition of employment applications and/or resumes, and acquisition of skills needed to maintain and/or advance one's employment in the workplace. Course content also may include consumer education and personal money management. It is recommended that students who select this course have completed the Career Exploration course.

WORKPLACE EXPERIENCE

Number: 980400
Prerequisite: Special Educational Eligibility & Current IEP
Credit: 1
Grade: 9-12

This course provides students with workplace experience—ideally in a field or workplace related to their career interest. Goals are established cooperatively by the student, teacher, and employer (although students may not receive compensation). This course may include classroom activities that involve further study of the field of interest, or further discussion of experiences that students encounter in the workplace.

RESOURCE AND ACADEMIC SUPPORT

Number: 786550
Prerequisite: Special Educational Eligibility & Current IEP
Credit: 1
Grade: 9-12

This elective course is delivered in a small, supportive educational environment designed to help the student improve academic, social, and transition skills, to identify and reinforce the student's strengths, and to remediate learning deficits identified in the IEP.

INDEPENDENT LIVING SKILLS

Number: 781000
Prerequisite: Special Educational Eligibility & Current IEP
Credit: 1
Grade: 9-12

The Independent Living Skills program is based upon the Virginia Aligned Standards of Learning (ASOL). This special education program is offered to meet the needs of students with moderate to severe cognitive impairments. The course focus is on developing functional academics in English, Math, domestic skills, career preparation and transition skills, recreation and leisure, and community-based instruction. The curriculum is designed to teach independent living skills, to increase students' functional reading and math skills, to become aware of their impact on their community and acknowledge and accept responsibility for their actions. Students enrolled in the Independent Living Skills program work toward goals and objectives as specified in their Individualized Education Plan (IEP). This course does not satisfy the credit-bearing requirements for a Modified, Standard, or Advanced diploma.

LIFE SKILLS

Number: 789601
Prerequisite: Special Educational Eligibility & Current IEP
Credit: 1
Grade: 9-12

Introduction and comprehension of living skills to include personal management, safety and health, social communication, mobility, recreation and leisure, food preparation, home living and management, using services, wellness, and nutrition competencies. Definitions will be addressed as written in the Applied Studies Curriculum Map on the VDOE.

Early College Scholars

The Governor's Early College Scholars program recognizes students who pursue college-level coursework during high school and allows eligible high school students to earn transferable* college credit while completing the requirements for an Advanced Studies Diploma. The result may be a more productive high school academic experience with potential to reduce college tuition expenses. Students who fulfill the terms of the signed agreement are recognized as Early College Scholars and receive a certificate of recognition from the Governor.

To qualify for the Governor's Early College Scholars program, a student must:

- Have a "B" average or higher; *and*
- Be pursuing an Advanced Studies Diploma; *and*
- Demonstrate ability to complete college-level course work (i.e. Advanced Placement, International Baccalaureate, Cambridge, or dual enrollment) that will earn at least 15 transferable* college credits, *and*
- Complete a signed Early College Scholars Agreement by March of the senior year.

A copy of the Agreement and other details can be viewed on the Virginia Department of Education website:
www.doe.virginia.gov/instruction/graduation/early_college_scholars/

* *Transferble* college credits may be earned for specific courses when other qualifying criteria are met (e.g. minimum qualifying scores on Advanced Placement exams, or dual-enrolled courses recognized by specific transfer degrees and Guaranteed Admissions Agreements of the Virginia Community College System). For additional information, contact your child's school counselor.

Dual Enrollment Courses

- GHS students may be eligible to earn college credit from Rappahannock Community College (RCC) for completion of particular courses (known as dual-enrollment) at Gloucester High School.
- Dual enrollment courses meet high school and college course requirements and may satisfy certain college course requirements at colleges or universities other than RCC; however, institutions of higher education have unique and specific policies regarding acceptance of college-level transfer credit. Consult with your school counselor or RCC's Dean of Dual Enrollment for clarification.
- Dual enrollment credits awarded by RCC require a \$15 per credit fee to be paid by the student. Students in dual enrollment courses who do not pay the dual enrollment fee by the established RCC withdrawal deadline will not earn RCC credits and may be withdrawn from the course for nonpayment of tuition. Some dual enrolled courses (i.e. English 12 Dual) will have credit fees billed in both fall and spring. Other dual enrolled courses (i.e. Medical Terminology) are semester courses and will be billed only one time.
- Students wishing to take dual enrollment courses must demonstrate they are prepared for college level work by earning a qualifying score on the Virginia Placement Tests. These English and Mathematics placement tests are administered in the spring semester at GHS. Students who do not qualify on these placement tests will not be allowed to enroll in a dual enrollment course.
- Students must have a dual enrollment application on file with RCC.
- Students must have their RCC application on file at RCC and have scored high enough on the Virginia Placement Test (VPT) by May 15 to be eligible to take requested dual enrollment courses.
- Academic dual enrollment courses are weighted on the grading scale. Students must earn a "C" or better to receive college credit. Students who do not receive a "C" or better at mid-year will be removed from the dual enrollment course.
- Students who earn grades in dual enrollment courses will have a permanent transcript at RCC in the Virginia Community College System. This transcript will be sent to colleges and universities if requested by the student.
- Performance in dual enrollment courses must be taken seriously; poor grades on a college level transcript can affect financial aid eligibility.
- Gloucester High School students who are accepted in a dual enrollment course are considered Rappahannock Community College students and will have access to all resources in the RCC Learning Resource Center with an RCC ID. The Learning Resource Center features books, printing and scanning services, library computers, reserve research items, quiet study centers, and research tools. Students have access to the Success Labs and the Testing Center.
- To qualify for an RCC dual-enrollment course:
 - STEP 1: Consult with your teachers and school counselor;
 - STEP 2: Request dual-enrollment course(s) when scheduling for the next school year;
 - STEP 3: Submit your completed RCC dual-enrollment application to your school counselor;
 - STEP 4: Consult with your school counselor to take the VPT after school or at RCC before the May 15 deadline; refer to bulleted information above for additional details.
 - STEP 5: Pay the dual enrollment fee of \$15 per credit prior to the deadline. Deadlines typically are prior to the start of a class. Failure to pay could result in removal from the course.

Dual Enrollment Courses at RCC

GHS Course No.	GHS Course Description	GHS Credit	RCC Course No.	RCC Course Description	RCC Credit
116055	English 12	1	ENG 111 ENG 112	College Composition I College Composition II	3 3
236055	United States History	1	HIS 121 HIS 122	US History I US History II	3 3
244055	United States Government	1	PLS 135 PLS 136	American National Politics State and Local Politics	3 3
316255	Math Analysis	1	MTH 163 MTH 164	Pre-Calculus I Pre-Calculus II	3 3
432055	Biology II	2	BIO 101 BIO 102	General Biology I General Biology II	4 4
434055	Ecology	1	BIO 270 BIO 275	General Ecology Marine Ecology	4 4
803400	Horticulture	1	HRT 106/110 HRT 115	Practical Horticulture/Principles of Horticulture Plant Propagation	4 3
803500	Greenhouse & Plant Mgmt	1	HRT 121 HRT 122	Greenhouse Crop Production I Greenhouse Crop Production II	3 3
803600	Landscaping	1	HRT 125 HRT 126	Chemicals in Horticulture Home Landscaping	3 3
827500	Culinary Arts I	2	HRI 106 HRI 115 HRI 134	Principles of Culinary Arts I Food Service Mgr Sanitation Cert. Food and Beverage Service Mgmt	3 1 3
827600	Culinary Arts II	2	HRI 128 HRI 145 HRI 218	Principles of Baking Garde Manager Fruit, Vegetable, and Starch Preparation	3 3 3
839000	Introduction to Nutrition for Health & Medical Sciences	1	HLT 230 SDV 101	Prin. of Nutrition & Human Develop. Orientation to Health Sciences	3 1
870200	Introduction to Criminal Justice	1	ADJ 100	Introduction to Criminal Justice	3

Concurrent College Enrollment

Eligible GHS students may choose to take classes at RCC or other college/university to earn both high school and college credit. Students wishing to take a concurrent course at RCC or other college/university must obtain approval from the principal prior to enrollment. Consideration for concurrent credit for courses taken at RCC or other college/university will include the following information:

- Is the course taught at GHS as a dual-enrolled course?
- Has the student exhausted the available high school course offerings in the particular subject area?
- Is a comparable weighted course taught at GHS, such as Honors, Advanced Placement, or through a Governor’s School?
- Has a comparable course been offered at GHS as dual-enrolled?

The following criteria apply to all students who are approved for concurrent enrollment:

- The student is responsible for completing all action items related to college course registration.
- The student assumes all costs associated with the course.
- The course becomes a part of the permanent high school and college transcript.
- Students may earn only one concurrent college credit per academic semester (summer included).
- High school credit is awarded when the student supplies an official college transcript prior to the end of the high school semester in which the concurrent course is taken. College credit is determined by each individual college or university.
- Students who take a concurrent college course as part of the full-enrollment requirement and who (1) drop the course and/or (2) do not supply an official college transcript before the end of the high school semester will receive a grade of “F” on the high school transcript for that course.
- A concurrent college courses will be weighted in accordance with GCPS policy when calculating final GPA. Concurrent college courses excluded from weighting include all introductory courses and world languages that do not exceed the rigor of Advanced Placement.

Advanced Placement Courses

- AP courses are college level courses that culminate in an end of course AP exam. AP exam scores are reviewed by colleges and will be accepted as college credit under certain conditions.
- AP courses are weighted on the grading scale, and are marked with an asterisk (*) on the transcript.

GHS Course No.	Course Title	Credit	9	10	11	12	Other Information
119505	English 11 AP	1			x		English 10 and required summer reading
119605	English 12 AP	1				x	English 11 and required summer reading
238005	World History AP	1		x			World History I, co-enrolled in English 10 Honors
221205	Human Geography AP	1		x	x	x	World History I, Grade 10 or higher
231905	US History AP	1			x		Required summer readings
244505	Government AP	1				x	United States History
290255	Psychology AP	1			x	x	Strong language and writing skills
317755	Calculus AB AP	1			x	x	Math Analysis/Precalculus
317756	Calculus BC AP	1				x	Calculus AB
319292	Statistics AP	1		x	x	x	Trigonometry and Statistics or Math Analysis
437005	Biology II AP	2		x	x	x	Biology I and Chemistry I
447005	Chemistry II AP	2		x	x	x	Chemistry I
457005	Physics AP	1			x	x	Physics and Algebra II
517005	French V AP	1				x	French IV
557005	Spanish V AP	1				x	Spanish IV
914900	Art Portfolio AP	1			x	x	At least one studio course
922501	Music Theory AP	1			x	x	Prior music course experience

Virtual Virginia AP Courses

The Virtual Virginia Advanced Placement School (VVAPS) offers online AP courses to students across the commonwealth and nation. Each course contains video segments, audio clips, whiteboard and online discussions as well as text. E-Teachers are available for telephone conversations with students throughout the school day. VVAPS classes offer a rich multimedia learning environment that appeals to a variety of learning styles. Self-disciplined students may enroll in Virtual Virginia Online AP Courses. Virtual Virginia course offerings are only available for those classes that are not taught at GHS. *Students must enroll in these courses for the year and attend a regularly scheduled classroom environment at GHS.* A contract is required. **Please note:** Students who drop these courses after the deadline will incur a \$75 fee. Students who are not identified as an “Early College Scholar” may be required to pay tuition or associated fees.

GHS Course No	Virtual Virginia Course Title	Credit	9	10	11	12	Prerequisite
239905	European History AP	1		x	x	x	World History I grade C or above & contract
318505	Computer Science A AP	1		x	x	x	Algebra II Honors or Trig grade C or above & contract
427005	Environmental Science AP	1			x	x	Earth Science, Algebra I, and either Bio I or Chem I & contract
538005	Latin: Virgil AP	1				x	Latin III grade C or above & contract
915100	Art History AP	1				x	World History I, World History II & Art History & contract

Virtual Learning Programs

Students may be eligible to enroll in an online (virtual) course available through either *Virtual Virginia* (provided through the Virginia Department of Education) or the division’s currently approved online provider. All virtual learning courses require advance approval from the principal, counselor, and parent. Once approved, eligible students may earn either initial or recovery credit.

- Course offerings are available only for those classes not offered at GHS (the principal may grant exceptions to this policy as necessary). Prior to approval for any *Virtual Virginia* course, students are required to meet with their counselor to discuss academic plans and available alternatives to scheduled courses.
- Students must enroll in *Virtual Virginia* courses for the entire school year and attend a scheduled classroom at GHS during the regular school day. A participation contract is required. *Virtual Virginia* course descriptions are listed under the Department headings in this publication. Many of the *Virtual Virginia* courses are Advanced Placement (AP).
- Students who drop these courses after the deadline will incur a \$75 fee. Students who are not identified as an “Early College Scholar” may be required to pay tuition or associated fees. Students will also be required to attend a technology orientation and parents are encouraged to attend an informational meeting about *Virtual Virginia* online learning.
- For more specific information about participation in *Virtual Virginia* courses, contact a school counselor and visit www.virtualvirginia.org. Regarding other virtual learning opportunities: students may be eligible to enroll in virtual classes for a variety of reasons. Students and parents should consult with their school counselor for course information and eligibility criteria.

GHS Course No.	Virtual Virginia Course Title	Credit	9	10	11	12	Prerequisite
116500	World Mythology	1		x	x	x	Strong Writing Skills
501000	Arabic I	1		x	x	x	None
502000	Arabic II	1			x	x	Arabic I
581000	Chinese I	1		x	x	x	None
582000	Chinese II	1			x	x	Chinese I
583000	Chinese III	1				x	Chinese II
531090	Latin I	1	x	x			None
532005	Latin II	1		x	x		Latin I
533090	Latin III	1			x	x	Latin II

Chesapeake Bay Governor's School

The Chesapeake Bay Governor's School provides high-ability students from the Northern Neck and the Middle Peninsula with a rigorous curriculum through enrichment, exploratory, investigative, and career awareness experiences. Through the integration of math, science, technology, and research, woven with marine and environmental sciences, students have the opportunity to foster an appreciation and respect for environmental issues.

The Chesapeake Bay Governor's School for Marine and Environmental Science provides a community of learners the opportunity to explore connections among the environment, math, science, and technology in order to help develop leaders who possess the research and technical skills, global perspective, and vision needed to address the challenges of a rapidly changing society. Admission is competitive and is based on previous math and science courses, teacher recommendations, standardized achievement testing, science/math activities, and honors. Student selection is determined by each participating school system. For specific criteria and an application, a prospective student should contact his/her high school counseling department or the Gifted Services Office at GCPS. Applications may be obtained through each local school division.

CBGS is a morning program with courses offered at the Glens Campus of Rappahannock Community College. Transportation is provided; leaving at 7:20 am from GHS and returning at 11:00 am.

Grade Level	GHS Course No.	GHS Course Description	GHS Credit	RCC Course No.	RCC Course Description	RCC Credit
10	316265	Advanced Algebra II/ Pre Calculus CBGS	1	MTH 163 MTH 164	Precalculus I Precalculus II	3 3
10	431065	Biology I CBGS	1	BIO 101 BIO 102	General Biology I General Biology II	3 3
10	461065	Foundations of Science CBGS	1	ITE 115 SCT 111	Basic Computer Literacy General Science	3 4
11	317765	Calculus AB CBGS	1	MTH 175 MTH 176	Calculus I / Analytic Geometry Calculus I/ Analytic Geometry	3 3
11	319065	Statistics I CBGS	1	MTH 240	Statistics	3
11	442065	Environmental Chemistry I CBGS	1	CHEM 111 CHEM 112	General Chemistry I General Chemistry II	4 4
11	461165	Environmental Science I CBGS	1	MAR 201 MAR 202	Marine & Environmental Science I	4 4
12	317766	Calculus BC CBGS	1	MTH 174	Calculus II/ Analy. Geometry	5
12	452065	Environmental Physics CBGS	1	PHYS 201 PHYS 202	General College Physics General College Physics	4 4
12	461265	Environmental Science II CBGS	1	MAR 101 MAR 102	Marine & Environmental Science II	4 4

ADVANCED ALGEBRA II/PRECALC CBGS

Number: 316265
Prerequisite: Acceptance to CBGS
Credit: 1
Grade: 10

The advanced Algebra II / Precalculus course taught to Chesapeake Bay Governor's School sophomores will encourage the exploration of mathematical ideas, data, patterns and algebraic concepts. The course will require the student to be an active participant and to model the ways that mathematics is applied to science and the real world. Students will be provided with opportunities to pursue individual interest in mathematics. The course is Advanced Algebra, but will blend algebra, geometry, discrete mathematics, and probability. This course will prepare our students to succeed in their future CBGS mathematics & science courses by giving them a solid foundation of algebra skills to build on.

CALCULUS AB CBGS

Number: 317765
Prerequisite: Acceptance to CBGS
Credit: 1
Grade: 11

The Trigonometry/Calculus course taught in the second semester to Chesapeake Bay Governor's School juniors will encourage their understanding of the concepts and applications of trigonometry. Students will learn hands-on the basis definitions of the six trig functions and their inverses, and use graphing utilities to examine graphs with changes in periods, amplitudes and asymptotes. Students will investigate trigonometric identities and use all their skills to solve trig equations. The Laws of Sines and Laws of Cosines will be used for practical problems and lead to vector analysis. Polar and parametric graph coordinates will be investigated. The students will be prepared to examine the applications of trigonometry to physical, chemical and environmental phenomena as well as Calculus.

CALCULUS BC CBGS

Number: 317766
Prerequisite: Acceptance to CBGS
Credit: 1
Grade: 12

The Calculus course will be taught over 2 semesters at Chesapeake Bay Governor's School to seniors. The Calculus course will present algebraic and transcendental functions, including the study of limits, derivatives, differentials, rectangular and polar graphing, indefinite and definite integral, area and volume, methods of integration, differential equations and power series. Students will investigate these topics along with their applications to physical, chemical, and environmental phenomena in the real world.

STATISTICS I CBGS

Number: 319065
Prerequisite: Acceptance to CBGS
Credit: 1
Grade: 11

The Statistics class will cover one semester of the junior year presenting an overview of statistics, including descriptive statistics, elementary probability, probability distributions, estimation, hypothesis testing, and correlation and regression. Students will apply statistical methods to their two-year research paper.

BIOLOGY I CBGS

Number: 431065
Prerequisite: Acceptance to CBGS
Credit: 1
Grade: 10

The Biology course taught to the Chesapeake Bay Governor's School sophomores will focus on those major concepts or themes deemed to be essential to an understanding of life processes. Throughout the year science as a process will be emphasized as students conduct laboratory studies to support classroom information, use inductive reasoning to discover key concepts, study the history of the development of our present understanding of biological concepts, and learn how to conduct their own research. Other major themes are genetics, evolution, energy transfer, the relationship between structure and function, ecological interrelationships, the regulation of processes at many levels, and the impact of science and technology on our society. This course, in conjunction with the topics course, will adequately prepare our students to succeed in their next two years at CBGS, in college, and in their future endeavors, as they will learn to focus their efforts and master essential study skills. CBGS Biology students will also be able to succeed on the Virginia Standards of Learning End of Course Biology Exam.

ENVIRONMENTAL CHEMISTRY I CBGS

Number: 442065
Prerequisite: Acceptance to CBGS
Credit: 1
Grade: 11

The junior Chemistry course will explore fundamental laws, theories, and mathematical concepts of chemistry, and will cover the structure of matter, the characteristics of the states of matter, types of reactions, thermodynamics, chemical kinetics, equilibrium, and electrochemistry. The lab component of the course, which counts approximately twenty percent of the overall grade, will focus on qualitative and quantitative support of the general chemistry concepts.

ENVIRONMENTAL PHYSICS I CBGS

Number: 452065
Prerequisite: Acceptance to CBGS
Credit: 1
Grade: 12

This college level course taught in the senior year covers the fundamental principles of physics and quantitative application of these principles to problem solving. Topics include mechanics, oscillations, and wave motion, electricity and magnetism and selected topics from modern physics. Students will understand the concepts qualitatively and be familiar with the mathematical models which describe these concepts quantitatively. Algebra and pre-calculus are prerequisites for this course and an understanding of algebra, geometry and trigonometry is essential. While calculus is not a prerequisite it is a co requisite for this course and will be helpful in understanding the concepts.

FOUNDATIONS OF SCIENCE

Number: 461065
Prerequisite: Acceptance to CBGS
Credit: 1
Grade: 10

This sophomore level course will be technology based and include: ITE 115 Basic Computer Literacy and will explore the Earth Science systems with an emphasis on the geology of the Chesapeake Bay Watershed. To include developmental science methods, data collection using the globe program, etc.

ENVIRONMENTAL SCIENCE I and II CBGS

Number: 461165 / 461265

Prerequisite: Acceptance to CBGS

Credit: 1

Grade: 11 / 12

A two-year lab and field science course for juniors & seniors designed to provide thematic unity to the CBGS program and immerse students in rich experiential learning. Students will explore the principles of general ecology, evolutionary biology, environmental science, and oceanography, with special emphasis on the natural history and ecology of the Chesapeake Bay and its watershed as well as the Atlantic Ocean and east coast. The entire two-year course is interdisciplinary in spirit, stressing the importance of chemical, physical, and geological oceanography for understanding marine life and aquatic ecosystems, while making frequent connections to the mathematics and general sciences that students are learning in other CBGS courses. The curriculum will largely be driven by the data and investigations of real scientists, and students will design and conduct their own scientific research.

New Horizons Governor's School

The Governor's School for Science and Technology at New Horizons Regional Educational Center provides a cohesive, innovative science and mathematics program. Students will choose from three strands of courses: Engineering, Biological Sciences, and Scientific Programming.

Each strand requires completion of one year of high school biology, one year of high school chemistry, and Algebra II/Trig prior to admission. In total, students will spend approximately 3 hours at the Governor's School, taking three courses each year during the two-year program at the Hampton Campus of New Horizons on Butler Farm Road.

Admissions to the program is highly competitive. Test scores as well as teacher recommendations and course grades will be used to determine which students will be invited to participate in the Governor's School Pre-Admissions Series offered in 9th and 10th grade. GCPS will pay for the costs associated with the Governor's School, however, students must pay TNCC or CNU for any requested dual enrollment credits.

Designated students will take prerequisite courses offered in their high schools and will participate in a variety of specific activities offered at the school that will acquaint with and prepare them for the two-year program. For more information, see your counselor or contact Gifted Services at GCPS Central Office. For more information visit <https://nhrec.org/gsst/>

Strand	Grade Level	GHS Course No.	GHS Course Description	GHS Credit	TNCC/ CNU Course Description	TNCC/CNU Cr.
Engineering	11	317775	Calculus	1	Calculus	8
	11	457175	Calculus Based Engineering Physics	1	Calculus based Engineering Physics: Found. & Modeling	4
	11	461075	Research Methodology & Ethics	1	None	0
	12	317875 or 319075	Multivariable Calculus/Linear Algebra or Statistics	1	Multivariable Calculus Statistics	7 3
	12	458075	Calculus Based Engineering Physics II	1	Calculus based Engineering Physics: Maxwell to Hawking	4
	12	462175	Research & Mentorship Program	2	None	0
Biological Sciences	11	316275 or 317775	Modern Pre-Calculus or Calculus	1	Pre-Calculus or Calculus	6 or 8
	11	447175	Advanced Chemical Analysis	2	Biological & Chemical Analysis	16
	11	461075	Research Methodology & Ethics	1	None	0
	12	317775 or 317875 or 319075	Calculus or Multivariable Calculus/Linear Algebra or Statistics	1	Calculus or Multivariable Calculus or Statistics	8 or 7 or 3
	12	437175	Advanced Biological Analysis	2	Advanced Chemical Analysis	8
	12	427175/461275	Environmental Science: Research Application/Mentorship	2	Concepts & Controversies in Environmental Science	4
Scientific Programming	11	316275 or 317775	Modern Pre-Calculus or Calculus	1	Pre-Calculus or Calculus	6 or 8
	11	457075/ 318175	Inquiry Physics & Scientific Programming I	2	Inquiry Physics & Scientific Programming I, Dynamics	4
	11	461075	Research Methodology & Ethics	1	None	0
	12	317775 or 317875 or 319075	Calculus or Multivariable Calculus/Linear Algebra or Statistics	1	Calculus or Multivariable Calculus or Statistics	8 or 7 or 3
	12	452075/ 318275	Inquiry Physics & Scientific Programming II	2	Inquiry Physics & Scientific Programming II, Digital Devices	4
	12	461275	Research & Mentorship Program	2	None	0

Program Model for GSST, 2021-22 SY

(**College Credit Subject to Review)

Revised 10.01.19

*Prerequisites: Biology and Chemistry with a Math minimum of Pre-Calculus			
11th Grade	Engineering Physics I & II: Calculus-based Physics 2 HS Science/8 TNCC credits	Research Methodology w/ Statistical Analysis 1 HS Elective/3 TNCC Statistics credits	Calculus/MV/LA 1 HS Math/8 TNCC credits Calculus 1 HS Math/7 TNCC credits MV-LA
12th Grade	Calculus-based Engineering Physics III & IV: Engineering Design 2 HS Science/4 TNCC credits *pending approval	Honors Research/Mentorship 2 HS Electives/2 TNCC credits	Multivariable-Linear Algebra/Applied Calculus/Differential Equations (DE) 1 HS Math/7 TNCC credits MV-LA 1 HS Math/3 TNCC credits Applied Calculus 1 HS Math/3 TNCC credits DE
Biological Science Strand *Prerequisites: Biology and Chemistry with a Math minimum of Algebra II/Trig *Biological Science - It is highly recommended that students take high school Physics at their home school division			
11th Grade	Advanced Chemical analysis 2 HS Science/8 TNCC credits	Research Methodology w/ Statistical Analysis 1 HS Elective/3 TNCC Statistics credits 1 HS Math/8 TNCC credits Calculus	Modern Pre-Calculus/Calculus/MV/LA 1 HS/6 TNCC credits for Pre-Calculus 1 HS Math/8 TNCC credits Calculus 1 HS Math/7 TNCC credits MV-LA
12th Grade	Advanced Biological Analysis 2 HS Science/8 TNCC credits	Honors Research/Mentorship 2 HS Electives/2 TNCC credits	Calculus/Multivariable-LA/Applied Calculus/MV/LA 1 HS Math/8 TNCC credits Calculus 1 HS Math/7 TNCC credits MV-LA 1 HS Math/3 TNCC credits Applied Calculus 1 HS Math/3 TNCC credits Differential Equations
Computational Science *Prerequisites: Biology and Chemistry with a Math minimum of Algebra II/Trig			
11th Grade	Computational Physics I: Algebra-based Physics I & II 2 HS Science/8 TNCC credits	Research Methodology w/ Statistical Analysis 1 HS Elective/3 TNCC Statistics credits	Modern Pre-Calculus/Calculus/MV/LA 1 HS/6 TNCC credits for Pre-Calculus 1 HS Math/8 TNCC credits Calculus 1 HS Math/7 TNCC credits MV-LA
12th Grade	Engineering Design, Innovation & Entrepreneurship 2 HS Science/14 TNCC credits *pending approval	Honors Research/Mentorship 2 HS Electives/2 TNCC credits	Calculus/Multivariable-Linear Algebra/Applied Calculus/Differential Equations (DE) 1 HS Math/8 TNCC credits Calculus 1 HS Math/7 TNCC credits MV-LA 1 HS Math/3 TNCC credits Applied Calculus 1 HS Math/3 TNCC credits Differential Equations
			4 HS/18-19 college credits
			5 HS/9-13 college credits
			Total 9HS/27-32 college credits
			4 HS/17-19 college credits
			5 HS/13-18 college credits
			Total 9 HS/30-37
			4 HS/17-19 college credits
			5 HS/19-24 college credits
			Total:9 HS/36-43 college credits

*It is imperative that students meet with their school counselor to ensure requirements for Advanced Diploma are met.

**Dual Enrollment credits and fees, (which are determined by the Virginia Community College System and Thomas Nelson Community) are not guaranteed and are subject to change at any time based on staffing and course College requirements (TNCC).

COLLEGE MODERN PRE-CALCULUS NHGS

Number: 316275
Prerequisite: Acceptance to NHGS
Credit: 1
Grade: 11

This course is an intensive, rigorous approach to mathematics designed to prepare students for college calculus. First semester, students will focus on the algebraic and geometric properties of polynomial, rational, exponential, logarithmic, and trigonometric functions, and engage in discussions about how these models are represented in the real world. Second semester, students will learn the analytic properties of trigonometric functions and geometric conics, as well as learn the properties of polar coordinates, vectors, matrices, parametrics, and sequences and series. *The course concludes with an introduction to calculus.*

COLLEGE CALCULUS NHGS

Number: 317775
Prerequisite: College Modern Pre-Calculus
Credit: 1
Grade: 11

This course covers two semesters of university-level calculus for scientists and engineers, emphasizing understanding and application. The first semester covers limits and continuity of functions, techniques and applications of differentiation, and introduces integration. The second semester covers applications and advanced techniques of integration, differential equations, sequences and series, and analytical geometry. Upon completion of this course, student will understand both the geometric and rate of change analyses of differential and integral calculus. Students will apply their understanding of calculus to modeling real-world situations mathematically and be able to solve those mathematical models. *Successful completion of this course will prepare students to enroll in multivariable calculus/linear algebra.*

MULTIVARIABLE CALCULUS/LINEAR ALGEBRA NHGS

Number: 317875
Prerequisite: College Calculus
Credit: 1
Grade: 12

In multivariable calculus, students extend their study of calculus from the plane into 3-dimensional space and beyond. After an initial examination of geometry and algebra of 3-space, students will use differential and integral calculus to study the nature of curves and surfaces in 3-space. Topics include linear approximations of curves and surfaces in 3-space, optimization of functions in several variables, and use of integral calculus to study area, volume, and other applications. The semester concludes with an examination of the calculus of vector fields. In linear algebra, students use matrix theory to solve systems of linear equations and apply knowledge of the determinant to describe the nature of those solutions. The algebra and applications of linear transformations will be studied in both real and general vector spaces. Students will calculate eigenvalues and eigenvectors of linear transformations and use these to diagonalize linear systems. Applications include best fit functions and solutions of systems of 1st order, linear differential equations. *Prerequisite G.SST College Calculus or completion of AP Calculus BC with a score of 5 on the exam, or a score of 4 and permission of the instructor.*

DIFFERENTIAL EQUATIONS AND MATH METHODS IN PHYSICS NHGS

Number: 02123
Prerequisite: Multivariable Calculus/Linear Algebra NHGS
Credit: 1
Grade: 12

The first semester the emphasis will be on Ordinary Differential Equations (ODE). Partial Differential Equations (PDE) at the end of the first semester and conclude the second semester by looking at modeling the four fundamental forces and other applied topics. The construction of mathematical models to address real-world problems has been one of the most important aspects of each of the branches of science. It is often the case that these mathematical models are formulated in terms of equations involving functions as well as their derivatives. Such equations are called differential equations. These differential equations are the language in which the laws of nature can be expressed. Understanding the properties of solutions of differential equations is fundamental to much of contemporary science and engineering. If only one independent variable is involved, often time, the equations are called ordinary differential equations. The course will demonstrate the usefulness of ordinary differential equations for modeling physical and other phenomena. Complementary mathematical approaches for their solution will be presented, including analytical methods, graphical analysis and numerical techniques. This course also covers the classical partial differential equations of applied mathematics, physics, and engineering: diffusion, Laplace/Poisson, and wave equations. It also includes methods and tools for solving these PDEs, such as separation of variables, Fourier, Laplace, Legendre, Bessel series and transforms, eigenvalue problems, and Green's functions. Emphasis during the second semester will be placed on building and modeling the fundamental forces of nature. *Prerequisite for Differential Equations is successful completion of Multivariable Calculus/Linear Algebra and permission of the instructor.*

STATISTICAL RESEARCH METHODS NHGS

Number: 319075
Prerequisite: Pre-Calculus
Credit: 1
Grade: 12

This course is a comprehensive conceptual and practical presentation of probability, descriptive/inferential statistics, and the key ideas underlying statistical and quantitative reasoning. Statistical methods of organizing, summarizing, and displaying data combined with statistical testing are used to solve problems from a myriad of areas such as business, engineering, biology, and medicine. Advantages and limitations of statistical methods are developed. Graphing calculators and Minitab statistical software are extensively utilized. The emphasis is on the interpretation of the statistical results rather than the mere computation. Topics include random variables, sampling, distribution families, binomial and Poisson probabilities, conditional probability, estimations, data analysis, contingency tables, frequentist and Bayesian perspectives, simple and multiple regression analysis including linear, power, and exponential fit, confidence intervals, hypothesis testing for means and proportions, Chi-square, ANOVA, and several non-parametric testing, and design of experiments.

ENVIRONMENTAL SCIENCE: RESEARCH APPLICATIONS/MENTORSHIP NHGS

Number: 427175
Prerequisite: Bio & Chemical Analysis
Credit: 2
Grade: 12

In the fall semester, students integrate aspects of biology, chemistry, earth science, and physics in the study of the environment. Exploration of relationships between organisms and their biotic and abiotic environment at multiple levels of biological system hierarchy serves as the foundation for this course. Laboratory and fieldwork are integral components of the course. Students undertake field sampling for water quality and biotic components. While analyzing their own data, students will become familiar with concepts such as spatial and temporal variation in natural systems, species diversity, and community similarity indices. Critical thinking, risk analysis, and cost-benefit analysis will be emphasized as students identify and analyze alternative solutions to complex environmental problems. Current or on-going environmental issues and/or case histories will be emphasized. Spring semester will emphasize ecological principals from physiological ecology to ecosystem ecology. Mentorship involves students in concentrated research or project development in firms and laboratories throughout the Tidewater area. Students are supervised by mentors who are scientists, engineers, physicians and other professionals. Students plan, implement, document and present research or projects chosen in consultation with their mentors. Students refine their research and presentation techniques, problem-solving, critical thinking and leadership skills. Students gain proficiency with Minitab statistical software for presentation and analysis of data. *This course provides students with an opportunity to integrate theory, knowledge and application through a research experience.*

ADVANCED CHEMICAL ANALYSIS NHGS

Number: 447175
Prerequisite: Acceptance to NHGS
Credit: 2
Grade: 11

This course focuses on the fundamental principles and laws of chemistry. Extensive laboratory work will serve as the basic tools for students to explore chemistry topics. The course will provide insights into organic and inorganic chemistry. The students will explore advanced concepts such as kinetics, acid/base chemistry, equilibrium, thermochemistry, and electrochemistry. The course will emphasize problem solving through chemical calculations. *Advanced Chemical Analysis is a college-level course with a strong focus on laboratory work. It examines topics typically studied during the first year of college by science majors. Prerequisites: High school Chemistry and Algebra II/Trig.*

ADVANCED BIOLOGICAL ANALYSIS NHGS

Number: 437175
Prerequisite: Advanced Chemical Analysis
Credit: 2
Grade: 12

In the fall semester, topics in the field of cell and molecular biology will be addressed, some of which include the roles of biological macromolecules, cellular organization and metabolism, and cellular processes such as communication, reproduction, respiration, and photosynthesis. In addition, mechanisms of inheritance and control of gene expression will be examined, followed by a study of developments in biotechnology. In the spring semester, evolution, phylogeny, and the diversity of living things will be discussed, with a special focus on the anatomy and physiology of plants and animals. The laboratory experience is a major component of the course, allowing students the opportunity to use technologies applied in research, medical, and forensic laboratories while designing their own experiments and analyzing and interpreting their results. The anatomy and physiology of various vertebrate organ systems will be compared while dissecting animals in the laboratory. *Advanced Biological Analysis is a college-level course that examines the topics typically studied during the first year of college by biology majors. Prerequisite: Advanced Chemical Analysis.*

SCIENTIFIC PROGRAMMING I NHGS

Number: 451075/318175
Prerequisite: Acceptance to NHGS
Credit: 2 (1 credit each in math and science)
Grade: 11

This course will provide a thorough study of the key concepts in object-oriented programming (Java/Python) and design (data abstraction, data encapsulation, composition, inheritance and code re-use and implementation design techniques), programming constructs (primitives, references, classes, methods and interfaces), evaluating expressions (numeric, string and Boolean), program analysis (testing, debugging, run-time exceptions, pre and post conditions, assertions, analysis of algorithms and numerical representation of integers), data structures (strings, lists, one and two dimensional arrays and their accompanying operations – traversals, insertion and deletion), searching (sequential and binary), sorting (selection, insertion and merge sort) and develop an understanding of the ethical and social issues as it relates to the study of Computer Science. Topics in mechanics and thermodynamics are covered in physics at non-calculus level. *Prerequisite: Algebra II /Trig, Biology.*

SCIENTIFIC PROGRAMMING II NHGS

Number: 452075/318275
Prerequisite: Physics/Programming I
Credit: 2 (1 credit each in math and science)
Grade: 12

This course will provide an exhaustive study of data structures (linked lists, stacks, queues, binary search trees and graphs) and algorithms (searching, sorting, shortest path, and spanning tree). Students will also gain an ability to design programming projects which implement concepts in the areas of graphical user interfaces, networking, cryptography, machine learning and modeling and simulation of discrete and continuous systems. Students will continue to explore the advanced topics of object oriented programming in the Java programming language. *Prerequisite: Algebra II/Trig and Scientific Programming I.*

CALCULUS-BASED ENGINEERING PHYSICS I and II: MECHANICS TO ELECTROMAGNETISM NHGS

Number: 457175
Prerequisite: Acceptance to NHGS
Credit: 2
Grade: 11

This is a mathematical rigorous course that investigates the principals of classical mechanics, gravitation, periodic motion, electric and magnetic field theory, AC and DC circuit theory, geometric optics through in-depth discussion, concept development, and inquiry-based experimental laboratory activities. The course also develops problem solving skills which emphasize the importance of inquiry in science and integrates the overarching themes of conservation and symmetry. Laboratory experiments use apparatuses such as dynamic tracks, ballistic pendulums, and different LabPro sensors to investigate fundamental physics theories and mathematical concepts. Computer data acquisition software is utilized to collect, analyze, and graph experimental data. The course encourages hands-on activities, class participation, and students taking responsibility for their own learning. Students will be provided many opportunities throughout the course to design and carry out investigations and to analyze and evaluate data. Learning fundamental principles, generalizations, model-building, and the ability to apply course material to improve thinking, problem solving, and decision making are essential general goals. Gaining factual knowledge and developing specific skills, competencies, and points of view needed by professionals are important general goals. *Co-requisite: Enrollment in GSST College Calculus Course.*

CALCULUS-BASED ENGINEERING PHYSICS III and IV: MODERN PHYSICS AND APPLIED PHYSICS: ENGINEERING DESIGN PRINCIPLES NHGS

Number: 458075
Prerequisite: Engineering Physics I
Credit: 2
Grade: 12

Learning fundamental knowledge of engineering and physics disciplines and the requisite skills to perform research, problem-solve, innovate, and create opportunities in the real world are the overarching goals of this course. Extending the first-year physics material, this course includes investigations in modern physics topics such as relativity, quantum mechanics, and nuclear physics including, for example, conceptual understanding and practical applications of the wave function, Schrodinger's Equation, and radiation and radioactivity. The course includes also a series of project-based engineering learning experiences to help the student acquire and apply the skills, tools, and best practices of the engineering profession. Learning tools include, for example, industry standard engineering and research modeling and simulation software, hands-on design and troubleshooting of solid state electronics and digital systems, and industry standard computer-aided-design software, and additive manufacturing fabrication systems. In challenging keystone projects, students are tasked to identify real-world engineering problems or opportunities, to propose and seek client approval for their unique solutions or innovations, then to design, build, and demonstrate their final products. The keystone experiences include professional engagement with research and engineering leaders invited from community organizations such as NASA, SNAME, and the Jefferson Labs. *Prerequisites: Engineering Physics I & II, College Calculus.*

RESEARCH METHODOLOGY AND ETHICS NHGS

Number: 461075
Prerequisite: Acceptance to NHGS
Credit: 1
Grade: 11

Students will study contemporary issues in scientific research while conducting independent research projects outside of class. Students are encouraged to select projects consistent with their strand or career goals. Course topics include research design strategies, data analysis and representation (with and without computer-assistance), norms of conduct for ethical research behavior, and the historical basis for current research regulations, among others. All students must conduct a review of the primary literature to support their research design assumptions, prepare and present a plan of their proposed research for institutional review and approval, conduct their studies and report their findings via formal technical paper as well as oral presentation. All students present posters in our junior science symposium, judged by professionals in various fields. All students complete application materials for the Tidewater Science and Engineering Fair, and participation in this, and other fairs, is highly encouraged. *This course will serve as a preparatory course for the Honor Research and Mentorship Program.*

RESEARCH & MENTORSHIP NHGS

Number: 461275
Prerequisite: Research/Ethics
Credit: 1
Grade: 12

The Honors Research and Mentorship program (HRM) involves students in concentrated research or project development in firms and laboratories throughout the Tidewater area. They are supervised by mentors who are accomplished scientists, engineers and other professionals. Students must plan, implement, document and present research/projects chosen in consultation with these mentors. Accordingly, the students develop and refine their research and presentation techniques, problem-solving, critical thinking and leadership skills. This experience provides students with an opportunity to integrate theory, knowledge and application through a research experience.

New Horizons Career & Technical Education

GHS offers the following career and technical courses at New Horizons Career and Technical Education Centers, located at Butler Farm Campus in Hampton or the Woodside Lane Campus in Newport News.

Transportation to and from NHREC will be provided for all participants. For morning classes the bus leaves GHS at 6:30 am and returns at 11:00 am. For afternoon classes, the bus leaves at 11 am and returns at 3:30. **Students are responsible for getting to and from GHS for the bus. Students and parents will also be required to sign a contract guaranteeing attendance once students are accepted to NHREC.**

Courses showing a level II are two year programs. Students should plan on attending both years in order to be prepared for their industry certification exam. Courses marked with an * indicate dual enrollment agreements with Thomas Nelson Community College. Students may enroll at TNCC while taking the courses at NH. Those students with a grade of "C" or above will receive college credit through a transcript. Tuition fees have been waived for NH students. Gloucester students cannot enroll in programs at NHREC that are offered at GHS. **Please be advised that some programs may require supplies and fees. Costs indicated are approximate and should be used as a guide. Rising juniors and Seniors in good standing may apply for NHREC courses. Students who are interested in applying to NHREC need to seriously consider the commitment. Parents and students should be advised that commitment to these programs is for the full school year, so please take the application process seriously.**

Students must apply for all NHREC classes through a separate application process. Admission is determined by NHREC and not by GHS.

Please see the NHREC course descriptions and applications available on our website. *Fees are subject to change. Please speak to your counselor about departure/arrival times before you apply.

GHS Number	Course Description	Industry Certification	11	12	Fee *
828500	Early Childhood Education I	NOCTI Exam	x		\$63
828600	Early Childhood Education II	NOCTI Exam		x	\$60
830500/830600	Pharmacy Technician	NOCTI Exam	x	x	TBA
831000/831100	Veterinary Assistant	None	x	x	\$72
832800	Dental Careers I	None	x		\$41
832900	Dental Careers II	NOCTI Exam Radiation Health & Safety		x	\$85
833300/833400	Emergency Medical Technician I*	EMT State Certification Emergency Vehicle Operations Advanced First Aid Basic Life Support	x		\$145
833500	Emergency Medical Technician II*	Mass Casualty I and II Hazardous Materials Awareness		x	\$54
834500/834600	Medical Assistant I/II	NOCTI Exam	x		\$187
836000/836200	Nursing Assistant	NOCTI Exam Nurse Aid Certification	x	x	\$187
850300	Heating, Ventilation and Air Conditioning (HVAC) I	EPA Core Exam	x		\$64
850400	Heating, Ventilation and Air Conditioning (HVAC) II	Technician Certification		x	\$78
853300/853400	Electricity and Renewable Energy	NOCTI Exam	x	x	TBA
853900	Machine Technology I *	None	x		\$61
854000	Machine Technology II *	NOCTI Exam		x	\$35
855700	Intro to Electronics & Robotics	NOCTI Exam	x		\$16
855800	Advanced Robotics & Fiber Optics	Fiber Optics Installer Credential	x	x	\$47
860000	Basic Carpentry	NOCTI Exam	x	x	\$16
860100	Carpentry I	NOCTI Exam	x		\$55
860200	Carpentry II	NOCTI Exam		x	\$35
862200/862300	Computer Networking	NOCTI Exam Network + Certification	x	x	\$47

867200	Welding I	None	x		\$65
867300	Welding II	NOCTI Exam AWS Sense		x	\$35
867500	Auto Body Prep	None	x	x	\$16
867600	Auto Body I	None	x		\$49
867700	Auto Body II	NOCTI Exam		x	\$35
870200/870300	Criminal Justice *	NOCTI Exam	x	x	\$90
870500/870600	Firefighting	Firefighter State Certification I & II Hazardous Materials Operations Basic Life Support	x	x	\$79
870900	Auto Servicing and Detailing	None	x	x	\$16
874000	Barbering I	None	x		\$231
874100	Barbering II	NOCTI Exam		x	\$35

EARLY CHILDHOOD EDUCATION I

Number: 828500
Prerequisite: Acceptance to NHREC
Credit: 3
Grade: 11

EARLY CHILDHOOD EDUCATION II

Number: 828600
Prerequisite: Early Childhood Ed I
Credit: 3
Grade: 12

Students are expected to plan and prepare developmentally appropriate activities on a daily basis and implement these activities with a team in the on-site preschool laboratory. This laboratory is made up of disabled and non-disabled preschoolers, ages 2-5 years old. Topics of study are children's physical and intellectual development, establishing positive relationships with students and parents, principles of child growth, and strategies to manage an effective program of operation. Students are required to have completed English 10 with a grade of C or above. Students must provide their own craft supplies and have a current Tuberculin skin test.

PHARMACY TECHNICIAN

Number: 830500/830600
Prerequisite: Acceptance to NHREC
Credit: 3
Grade: 11 or 12

This program will provide students with an in-depth exposure to the pharmaceutical industry. It will assist students in becoming skilled in preparing/dispensing prescriptions, compounding medications, preparing intravenous medications, stocking medications, and repackaging medications. The Pharmacy Tech Program is a one-year course. Students must have completed Algebra I with a "C" or above.

VETERINARY ASSISTANT

Number: 831000/831100
Prerequisite: Acceptance to NHREC
Credit: 3
Grade: 11 or 12

Veterinary Technicians learn safe and respectful care and handling of classroom animals. Students develop understanding of various breeds and species of animals and are able to identify basic requirements for veterinary care and general health maintenance. Students receive training in handling, grooming, feeding and properly medicating a variety of animals. Nutrition, disease, and basic first aid also are explored. Students perform routine technical, maintenance and office duties associated with veterinary work. Career opportunities include veterinary assistants, laboratory and/or animal shelter caretakers, kennel attendants, and groomers.

DENTAL CAREERS I

Number: 832800
Prerequisite: Acceptance to NHREC
Credit: 3
Grade: 11

(See also Dental Careers II on next page)

DENTAL CAREERS II

Number: 832900
Prerequisite: Dental Careers I
Credit: 3
Grade: 12

This two-year program prepares students to perform all the tasks of a dental assistant. These tasks include exposing, processing, and mounting x-rays, preparing materials for various procedures including impressions, removing sutures, placing topical anesthetics, and making diagnostic study models for alginate impressions. Students study maintenance of patient records, sterilization and disinfectant of instruments and equipment, preparation of patients dental treatment and application of topical anesthetics, arrangement of dental instruments, materials, and medications on chair side trays, use of oral evaluation system, mixtures and preparation procedures of materials such as fillings and cements, laboratory procedures such as pouring, trimming and polishing cast, post op and oral hygiene instructions for patients, and taking, developing, and mounting X-rays.

EMERGENCY MEDICAL TECHNICIAN I

Number: 833300/833400
Prerequisite: Acceptance to NHREC
Credit: 3
Grade: 11 or 12

EMERGENCY MEDICAL TECHNICIAN II

Number: 833500
Prerequisite: EMT I & Instructor Invitation
Credit: 3
Grade: 12

Emergency medical technicians are one of the three public safety divisions (EMS, Fire & Law Enforcement). Their job includes the daily routine of dealing with crisis, trauma, hazardous materials, illness, injuries and the training to handle mass casualty situations, disaster management and terrorism awareness. The work they do often means the difference in life and death. Although the job can be stressful, EMT's and Paramedics enjoy the challenge and excitement of the jobs and view it as an opportunity to make a real difference. EMT students study medical; legal and ethical issues, anatomy and physiology, vehicle design and extrication, hazardous materials, patient assessment, treatment and transport, trauma, medical and environmental incidents, mass-casualty and disaster management, scent safety and personal protection, communications—written and oral, and pharmacology and ambulance operations. Career opportunities include city, state and federal fire departments, private and hospital based transport services, industry clinics, and hospital emergency departments and clinics. **EMT Students must be at least 16 years old.**

MEDICAL ASSISTANT I/II

Number: 834500/834600
Prerequisite: Acceptance to NHREC
Credit: 3
Grade: 11-12

This program prepares students to assist physicians by performing functions related to both business administration and clinical duties of a medical office. Instruction in the business aspect includes: insurance reporting, office accounting, medical records, and medical transcription. Clinical instruction includes: Preparation of the patient for examination and treatment, routing laboratory procedures and use of the electrocardiograph machine.

NURSING ASSISTANT

Number: 836000/836200
Prerequisite: Acceptance to NHREC
Credit: 3
Grade: 11-12

This course prepares students for employment as a Nurse's Assistant/Home Health Aid, and for entry into the practical nursing program. Students will receive clinical training in a local nursing home. This is a one year program. Upon completion of the program, students meeting the standard established by the State Board of Nursing and New Horizons, are eligible to take the National Nurse Aid Assessment Program examination to become a C.N.A. in Virginia.

HEATING, VENTILATION & AIR CONDITIONING I

Number: 850300
Prerequisite: Acceptance to NHREC
Credit: 3
Grade: 11

HEATING, VENTILATION & AIR CONDITIONING II

Number: 850400
Prerequisite: HVAC I
Credit: 3
Grade: 12

Students are taught the skills necessary for employment in the areas of heating and related climate control systems. Throughout the program, students gain daily practical experience in all aspects of air conditioning and also have the opportunity to receive refrigeration certification. HVAC students study Metering Devices; Compressors and Heat Pumps; Leak Detection, Evacuation, Recover, Charging; Air Properties and Distribution; Cutting, Threading and Joining Components; Heating System Design; Soldering and Brazing; Refrigerant Transition and Recovery; and Sizing, Installing, and Testing Water Systems. Career opportunities include Plant Maintenance Work, Supply Salesperson, HVAC Technician, Heating Mechanic, Engineering Laboratory Technician and Mechanical Engineer.

ELECTRICITY AND RENEWABLE ENERGY

Number: 853300/853400
Prerequisite: Acceptance to NHREC
Credit: 3
Grade: 11-12

Electricity and Renewable Energy first teaches the basic concepts used by electricians. Electricians install, maintain, and repair electrical wiring, equipment, and fixtures. Cabling and installation of communication wiring are also covered. As alternate renewable energies grow alongside the amount of electricity that's needed to keep up with our population, job prospects for those with electrician and renewable and energy trade training should be outstanding.

MACHINE TECHNOLOGY I

Number: 853500
Prerequisite: Acceptance to NHREC
Credit: 3
Grade: 11

MACHINE TECHNOLOGY II

Number: 854000
Prerequisite: Machine Tech I
Credit: 3
Grade: 12

In this program, students use machine tools such as drill presses, borers, lathes, and milling machines and produce precision metal parts that must meet exacting standards. Students also learn to use computers to program machines. Special tasks entailed in their program include: reviewing blueprints or written specifications, calculating where to cut and at what speed, determining proper tools and materials for the job, planning the cutting sequence, monitoring the machine process, maintaining and repairing machines, and consulting with Computer Numerical Control (CNC) programmers.

INTRO TO ELECTRONICS & ROBOTICS

Number: 855700
Prerequisite: Acceptance to NHREC and Algebra I grade of C or above
Credit: 3
Grade: 11

ADVANCED ROBOTICS & FIBER OPTICS

Number: 855800
Prerequisite: Intro to Electronics & Robotics OR Electronics I & II with a grade of C or above
Credit: 3
Grade: 11 -12

NOTE: Although these two classes form a two year sequence, students may take them separately. High school juniors who have completed Algebra I with a grade of C or above may take the introductory class and upon completing it with a C or above may take part II. Students who have completed Electronics I and II with a grade of C or above may enroll in Advanced Robotics/ Fiber Optics without taking the Intro class.

The intro course prepares students in basic electricity, electron theory, direct current fundamentals, and alternate current fundamentals, while emphasizing integrated circuits, digital fundamentals, and digital application. The advanced class provides instruction to computer programming, motor control, and feedback systems used in robotic assembly and manufacturing settings. In addition, students will program a microcontroller for robotic manipulation and focus on the application of fiber optics. In both courses, students will be given an opportunity to participate on the New Horizons Robotics Team.

BASIC CARPENTRY

Number: 860000
Prerequisite: Acceptance to NHREC
Credit: 3
Grade: 11-12

Learn the basics of carpentry, including reading blue prints, identifying and obtaining materials, measuring, marking and cutting materials, working with hand tools and power equipment, assembling parts, and installing materials according to plans.

CARPENTRY I

Number: 860100
Prerequisite: Acceptance to NHREC
Credit: 3
Grade: 11

CARPENTRY II

Number : 860200
Prerequisite: Carpentry I
Credit: 3
Grade: 12

This is a two year program that trains our future builders. Students develop the skills necessary for employment in the carpentry field. Throughout the program, students gain skills daily through practical experiences using hand and power tools. Students also participate in several building projects. Students must possess: the ability to read a ruler to 1/16th increments, basic math skills using fractions and decimals, eye-hand coordination, and a minimum proficiency of reading at the 8th Grade level.

COMPUTER NETWORKING ESSENTIALS

Number : 862200/862300
Prerequisite: Acceptance to NHREC
Credit: 3
Grade: 11 or 12

Students participate in the same on-line training program that is taught at college and corporate locations. Students also practice hands on networking skills such as cable construction, router configuration and network troubleshooting. Students will study fundamentals of computers and networking, open system interconnection, local area networks, wide area networks, internet operating systems, network security and troubleshooting, and wireless networks. Career opportunities include network administration, help desk technician, web design, telecommunication, network design.

WELDING I

Number: 867200
Prerequisite: Acceptance to NHREC
Credit: 3
Grade: 11

WELDING II

Number: 867300
Prerequisite: Welding I
Credit: 3
Grade: 12

Students in the Welding program will receive training along lines of Liebherr Mining and Northrop Grumman Newport News Shipbuilding Welding Schools, learn to set up welding equipment and do minor repairs, participate in building a variety of projects, have opportunities to network with people in the welding field and compete in district and state welding competitions. Welding students will study Welding Theory—variety of processes; Shielded Metal Arc Welding; Gas Metal Arc Welding—to include MIG, Pulse Arc, Short Arc; Flux Core; Tungsten Inert Gas (TIG) welding; Welding with carbon steel, stainless steel, aluminum; Brazing, Oxy Acetylene Burning; Carbon Arcing and Plasma Cutting. Career opportunities include Welder; Supervisor and Shop Owner.

AUTO BODY PREP

Number: 867500
Prerequisite: Acceptance to NHREC
Credit: 3
Grade: 11 or 12

This one year program is designed for students who are interested in collision repair but are unable to meet the requirements of the Auto Body or Refinishing Technician program. Students learn the very basics of the collision repair industry to include repairing a dent, welding, sanding, repairing plastic and fiberglass, using a primer and paint gun, mixing paint and pin striping. Mixing paint and pin striping. Each student entering this program will be required to spend about \$50 on an auto body kit that will contain a respirator as well as other related auto body tools. Students will be required to keep work related clothes at school. This course is not recommended for students with respiratory or allergy problems. Career opportunities include Auto Body Helper, Painter's Helper, Detailer, Auto Body & Paint Supply Store Assistant, and Marina or Boat Yard Assistant.

AUTO BODY I

Number: 867600
Prerequisite: Acceptance to NHREC
Credit: 3
Grade: 11

AUTO BODY II

Number: 867700
Prerequisite: Auto Body I
Credit: 3
Grade: 12

Students in the program are prepared for careers in their fields through the use of the latest technologies and state of the art equipment. Throughout the program, students gain daily practical experience by working on vehicles. Each student will become familiar with the latest finishes, from single-stage to multi-stage finishes. Selected students may be eligible for work experiences at local repair facilities. Successful completion of the two-year Auto Body program can reduce the two years of experience required for Automotive Service Excellence (ASE) certification by one year. Students must wear uniforms, safety glasses and leather work shoes. This course is not recommended for students with respiratory or allergy problems. Career opportunities include: Auto Body Repair & Restoration; Unibody Specialist & Assistant; Refinishing Specialist & Assistant; Automotive Graphics Specialist; Claims Adjuster; Vehicle Prep Person; Frame Specialist Assistant; Detailer; & Parts Specialist & Assistant.

CRIMINAL JUSTICE

Number: 870200/870300
Prerequisite: Acceptance to NHREC
Credit: 3
Grade: 11 or 12

Students in this program are preparing for many of the exciting, challenging, and rewarding careers in the criminal justice field. These opportunities require people who want to operate in both high energy and high tech fluid environments filled with constant challenges and service commitments. Students will study the history of and types of law enforcement requirements as they gain an understanding of local, state, and federal law enforcement agencies and jurisdictions. Students will learn about and use some of the newest technology in the criminal justice field as they undertake and engage in crime scene investigations. Some of the finest local, state, federal, and private sector professionals provide classroom presentations and hands on training opportunities. The program is dual enrolled with TNCC.

FIREFIGHTING

Number: 870500 / 870600
Prerequisite: Acceptance to NHREC
Credit: 3
Grade: 11 or 12

Firefighters are one of the three public safety divisions. Firefighter Level I prepares students to carry out most fire ground functions under the direct supervision of an officer. During Level II, you will assume more of a leadership role with safety problems, interior attacks and search operations. The program meets the requirements of the Virginia Department of Fire Programs. Students must be over the age of 16 with parents signed waiver acknowledging that the occupation of Firefighting and this training program exposes students to hazardous environments. All activities will be conducted with great care and supervised closely by qualified personnel. Students are not permitted to have facial hair or facial piercing that interferes in achieving proper seals with personal protective equipment. **Before enrolling students must pass a physical exam from their own physicians, using a NH form.**

AUTO SERVICING AND DETAILING

Number: 870900
Prerequisite: Acceptance to NHREC
Credit: 3
Grade: 11 or 12

This is a one-year course for students who are interested in automotive work, but are unable to meet the requirements of the automotive technician program. Students learn about keeping a car looking new by cleaning the engine, tires, chrome and aluminum parts, upholstery, vinyl and leather. They learn which solvents and cleaners work best on different surfaces. The servicing aspect of the course covers tire changing, balancing and rotation, battery servicing and replacement, vehicle lubrication and fluid servicing. Auto detailing requires repetitive, physically demanding work. Students may have to lift and carry heavy objects, stoop, kneel, crouch or crawl in awkward positions to get to those hard-to-reach places. Specific tasks include tire changing, cleaning all vehicle surfaces, battery servicing, vehicle lubrication and fluid servicing, tire balancing and rotation. Skills, abilities and personal characteristics include hand-eye coordination, manual dexterity, flexibility, physical strength, eye for detail, mechanical ability and the ability to tolerate repetitive tasks.

BARBERING I

Number: 874000
Prerequisite: Acceptance to NHREC
Credit: 3
Grade: 11

BARBERING II

Number: 874100
Prerequisite: Barbering I
Credit: 3
Grade: 12

Upon successful completion of this course, students are prepared to take the Commonwealth of Virginia State Barbering examination in order to become licensed practitioners. Students gain daily practical experience working on other students and during their second year has the opportunity to provide services to patrons in a clinical setting. Barbering students can also earn SOL credits for use as elective credit upon passing the NOCTI Exam or State Licensing Exam.

Greater Peninsula Governor's STEM Academy (GPGSA)

The Greater Peninsula is one of the initial six Virginia sites, selected by the Department of Education in 2008, to implement a Governor's STEM Academy. There are now approximately 30 such academies in Virginia. The purpose of this initiative is to prepare innovators and technologists for Virginia's workforce, especially in the area of Science, Technology, Engineering, and Mathematics (STEM).

GPGSA is a regional academy designed to focus on advanced academic and technical skills in each of the six Greater Peninsula school divisions (Gloucester County, Hampton City, Newport News City, Poquoson City, Williamsburg-James City County, York County). GPGSA is facilitated by New Horizons Regional Education Centers which is operated by the six greater Peninsula school divisions: The GPGSA emphasizes Engineering Technology and Information Technology and involves partners from education, business, postsecondary education, and non-profit organizations, including NASA Langley, Newport News Shipbuilding, and Canon Virginia.

The GPGSA offers courses of study in two career pathways; Engineering Technology and Information Technology. These are high growth and high compensation occupations within Hampton Roads and the Commonwealth of Virginia. The academy provides three levels of enrichment activities: Exploratory Saturdays (7th and 8th grade), Academic Preparation (9th and 10th grade); and Advanced Academics and Technical Training (11th and 12th grade). Academy courses may be offered at divisional high schools and/or at New Horizons Regional Education Centers (NHREC). Academy graduates:

- will be awarded a Governor's STEM Academy Diploma Seal and a Career and Technical Education Diploma Seal.
- are eligible to apply for guaranteed admission into the Thomas Nelson Community College (TNCC) A.A.S. in Engineering Technology program or A.A.S. in Information Technology Systems program.
- may receive priority consideration for acceptance into ODU's Engineering Technology or Business Information Technology degree program.
- may receive guaranteed admission into ECPI's Electronics Engineering Technology or Computer Information Science A.S. or B.S. degree program based on admission requirements.
- may earn industry credentials and/or transferable college credits to TNCC, ODU and The Apprentice School of the Newport News Shipbuilding.

Governor's Health Sciences Academy

The Gloucester High School GHSA was established in In June 2013 and is a partnership between Gloucester County Public Schools, Mathews County Public Schools, New Horizons Regional Technical Center, Riverside School of Health Careers, Riverside Health Systems, and Rappahannock Community College. The Governor's Health Sciences Academy (GHSA) will serve students in Gloucester County Public Schools and Mathews County Public Schools and will provide expanded options for students' health science literacy and other critical knowledge, skills, and credentials that will prepare them for high-demand, high-wage, and high-skill health sciences careers in Virginia; and will provide a comprehensive career readiness curriculum including rigorous academic content in five health sciences career pathways:

Support Services (2013-2014)
Therapeutic Services (2013-2014)
Diagnostic Services (2014-2015)
Health Informatics (2015-2016)
Biotechnology Research and Development (2015-2016)

NOTE: MCPS students are unable to participate in courses offered through NHREC.

Specific Governor's Health Sciences Academy objectives include: improved academic achievement of students in the Academy; increased completion of dual enrollment courses; work-based experiences for students through strong partnerships with businesses and health care institutions; increased high school graduation rates; and increased enrollment and retention in postsecondary education. Academy graduates will achieve one or more of the following benchmarks:

- Earn one or more industry certifications or state occupational licenses, and/or demonstrate competencies on an assessment instrument recognized by postsecondary institutions such as College Level Examination Program (CLEP) examinations or Uniform Certificate of General Studies, collaboratively designed or mutually approved end-of course tests, college placement tests, or student portfolios reviewed by a team of college and high school faculty; or
- Earn at least nine college credits as defined in the Early College Scholars program (includes dual-enrollment, Advanced Placement and other options); or
- Earn an Associate Degree.

Gloucester/Mathews GHSA Pathways

GHS Science		Therapeutic	Support	BioTech	Diagnostic*	Informatics
9 th	Earth Science	Introduction to Health & Medical Sciences	Introduction to Health & Medical Sciences	Introduction to Health & Medical Sciences	Introduction to Health & Medical Sciences	Introduction to Health & Medical Sciences
10 th	Biology	Medical Terminology	Medical Terminology	Medical Terminology	*Medical Terminology	Medical Terminology
11 th	Chemistry -or- Anatomy & Physiology	(1, 3, 4 & 5) Intro to Nutrition for Health & Medical Sciences -or- (2) Dental Assistant I (NHREC)	(1) Entrepreneurship I, -or- (2 & 4) Intro to Nutrition for Health & Medical Sciences -or- (3) Dental Assistant I (NHREC)	Entrepreneurship I	(1*, 2 & 3) Intro to Nutrition for Health & Medical Sciences -and/or- (1*) AP Psychology	(1) Entrepreneurship I, -or- (2) Intro to Nutrition for Health & Medical Sciences -or- (3) Dental Assistant I (NHREC)
12 th	Anatomy & Physiology -or- Chemistry	(1) Nursing Assistant I/II (NHREC), -or- (2) Dental Assistant II (NHREC), -or- (3) EMT I/II (NHREC), -or- (4) Pharm Tech I/II (NHREC), -or- (5) Medical Assistant I/II (NHREC), -or- (6) Vet Asst I/II (NHREC)	(1) Entrepreneurship II, -or- (2) Medical Assistant I/II (NHREC), -or- (3) Dental Assistant II (NHREC), -or- (4) Pharmacy Tech I/II (NHREC)	Entrepreneurship II	(1*) English 12 Dual Enrollment -and- (1*) RCC 100 level math, -or- (2) Medical Assistant I/II (NHREC), -or- (3) Pharmacy Tech I/II (NHREC)	(1) Entrepreneurship II, -or- (2) Medical Assistant I/II (NHREC), -or- (3) Dental Assistant II (NHREC)

(1*) Students who successfully complete this Diagnostic pathway will graduate with all or the majority of the 15 college credit hours that are prerequisites for admission to Riverside School of Health Careers in Radiologic Technology. Dual enrollment credits at both GHS and MHS are dependent upon teacher qualifications and RCC placement test scores established by the VCCS.

GHS STEM Academy

Science, Technology, Engineering and Mathematics fields are some of the fastest-growing career fields in the United States. Employers are seeking a workforce with educational backgrounds and skills in these areas. The STEM Academy at Gloucester High School is designed to provide students with an academic foundation in these areas to facilitate their transition into either a college STEM major, a training program in a STEM area, or to employment within a STEM career.

To participate in the GHS STEM Academy, students must submit a completed application to their school counselor during January of their eighth grade or ninth grade year. The STEM Academy is ideal for students with an affinity for science, math, and technology, as well as those students who are willing to commit to completion of their chosen STEM pathway.

GHS STEM Academy Engineering Pathway

	Science	Engineering Education	Math
9 th Grade	Biology (Honors with recommendation) Environmental Science (Honors or Traditional)	Construction Technology Technical Drawing	Algebra I Geometry (Honors or Traditional) Honors Algebra II
10 th Grade	Biology (Honors or Traditional) Chemistry (Honors or Traditional) Honors Physics	Construction Technology Technical Drawing Architectural Drawing & Design Engineering Drawing & Design Modeling & Simulation	Geometry (Honors or Traditional) Algebra Functions and Data Analysis Algebra II (Honors or Traditional) Math Analysis
11 th Grade	Earth Science Chemistry (Honors or Traditional) Honors Physics Anatomy and Physiology Biology II (DE)	Technical Drawing Architectural Drawing & Design Engineering Drawing & Design Modeling & Simulation Graphic Communications Systems	Algebra Functions and Data Analysis Algebra II (Honors or Traditional) Math Analysis Calculus AB Statistics
12 th Grade	AP Chemistry AP Biology ***AP Physics Honors Physics Anatomy and Physiology Biology II (DE) ****Capstone Science Course	Architectural Drawing & Design Engineering Drawing & Design Modeling & Simulation Graphic Communications Systems	Algebra Functions and Data Analysis Algebra II (Honors or Traditional) Math Analysis ****Calculus AB Calculus BC Statistics ***Capstone Math Course

GHS STEM Academy
Biomedical/Health Sciences Pathway

	Science	Health and Medical Sciences	Math
9th Grade	Biology (Honors with recommendation) Environmental Science (Honors or Traditional)	Introduction to Health and Medical Sciences	Algebra I Geometry (Honors or Traditional) Honors Algebra II
10th Grade	Biology (Honors or Traditional) Chemistry (Honors or Traditional) Honors Physics	Introduction to Health and Medical Sciences Medical Terminology Introduction to Nutrition for Health & Medical Sciences	Geometry (Honors or Traditional) Algebra Functions and Data Analysis Algebra II (Honors or Traditional) Math Analysis
11th Grade	Earth Science Chemistry (Honors or Traditional) Honors Physics ***Anatomy and Physiology Biology II (DE)	Medical Terminology Introduction to Nutrition for Health & Medical Sciences Sports Medicine Advanced Athletic Training Advanced Placement Psychology	Algebra Functions and Data Analysis Algebra II (Honors or Traditional) Math Analysis Calculus AB Statistics
12th Grade	AP Chemistry AP Biology AP Physics Honors Physics ***Anatomy and Physiology Biology II (DE) ***Capstone Science Course	Medical Terminology Introduction to Nutrition for Health & Medical Sciences Sports Medicine Advanced Athletic Training Advanced Placement Psychology	Algebra Functions and Data Analysis Algebra II (Honors or Traditional) Math Analysis Calculus AB Calculus BC Statistics

GHS STEM Academy Environmental Pathway

	Science	Engineering Education	Math
9th Grade	Biology (Honors with recommendation) Environmental Science (Honors or Traditional)	Biological Applications in Agriculture	Algebra I Geometry (Honors or Traditional) Honors Algebra II
10th Grade	Biology (Honors or Traditional) Chemistry (Honors or Traditional) Honors Physics	Biological Applications in Agriculture Horticulture Dual Greenhouse Management & Plant Production Dual	Geometry (Honors or Traditional) Algebra Functions and Data Analysis Algebra II (Honors or Traditional) Math Analysis
11th Grade	Earth Science Chemistry (Honors or Traditional) Honors Physics ***Environmental Science DE Biology II (DE)	Biological Applications in Agriculture Horticulture Dual Greenhouse Management & Plant Production Dual Veterinary Science	Algebra Functions and Data Analysis Algebra II (Honors or Traditional) Math Analysis Calculus AB ***Statistics
12th Grade	AP Chemistry AP Biology AP Physics Honors Physics Biology II (DE) ***Environmental Science DE ****Capstone Science Course	Biological Applications in Agriculture Horticulture Dual Greenhouse Management & Plant Production Dual Veterinary Science Landscaping Dual	Algebra Functions and Data Analysis Algebra II (Honors or Traditional) Math Analysis Calculus AB Calculus BC ****Statistics Capstone Environmental Course

RCC Degree Pathways:

- **Certificate of General Studies**
- **Associate's Degree**

As required by Virginia Statute HR 1184, “a written articulation agreement for postsecondary degree attainment with a community college in the Commonwealth specifying the options for students to complete an associate’s degree or a one-year Uniform Certificate of General Studies from a community college concurrent with a high school diploma” has been developed between Rappahannock Community College and Gloucester County Public Schools.

Rappahannock Community College has developed guaranteed admission agreements (GAAs) with some public colleges and universities in Virginia which offer opportunities for qualified students to transfer into a four-year college and university after completing an applicable RCC Associate’s degree and meeting other transfer requirements. Each four-year college or university is unique and has specific credit transfer requirements and conditions. In some instances, certain RCC courses or degrees (and certain GHS dual enrolled courses) may not transfer universally to every four-year college or university. Before selecting transfer electives to be applied toward a Certificate of General Studies and/or an Associate’s degree, students are advised to:

- Consult the transfer guides of prospective colleges and universities. Transfer information for many colleges/universities is available on the RCC website.
- Contact prospective colleges/universities to inquire about the transferability of particular courses.
- Consult with your school counselor or RCC’s Dean of Dual Enrollment.

As students and parents work to develop Academic Career Plans in the 7th and 8th grades they should familiarize themselves with these academic options. School counselors can help explain these two options as students and parents plan the various pathways to high school graduation. Academic Career Plans are reviewed as outlined by the Virginia Department of Education and students and parents can review progress towards these two academic pathways with their school counselor at any point along the road to graduation.

ADOPTED: December 11, 2012

REVISED:

February 12, 2013
March 12, 2013
August 13, 2013
December 10, 2013
March 11, 2014
May 13, 2014
October 15, 2014
December 10, 2014
October 22, 2015
January 12, 2016
September 13, 2016
March 14, 2017
April 11, 2017
September 12, 2017
April 10, 2018
June 12, 2018
December 11, 2018
January 8, 2019
May 14, 2019
January 14, 2020
November 10, 2020

LEGAL REFERENCES:

U.S. Const. amend. 1.
20 U.S.C. § 1400 et seq.
20 U.S.C. §§ 1681-1688.
29 U.S.C. § 701 et seq.
29 U.S.C. § 794.
42 U.S.C. § 12101 et seq.
42 U.S.C. §§ 2000d-2000d-7.
34 CFR part 106.

8 VAC 20-31-150.
8 VAC 20-40-20.
8 VAC 20-40-40.
8 VAC 20-40-50.
8 VAC 20-40-55.
8 VAC 20-40-60. A. 1.
8 VAC 20-81-50.
8 VAC 20-81-80.
8 VAC 20-81-100.

8 VAC 20-81-110.
8 VAC 20-81-130.
8 VAC 20-81-170.
8 VAC 20-120-40.
8 VAC 20-131-10 et seq.
8 VAC 20-131-30
8 VAC 20-131-110
8 VAC 20-131-110.B.3.
8 VAC 20-131-200.
8 VAC 20-131-270.
8 VAC 20-340-10.
8 VAC 20-360-10.
8 VAC 20-360-20.
8 VAC 20-680-10.
8 VAC 20-680-20.
8 VAC 20-720-90.

Code of Virginia, as amended, §§ 22.1-18.1; 22.1-26; 22.1-78; 22.1-79.1.B; 22.1-98; 22.1-200.1; 22.1-204; 22.1- 205; 22.1-206; 22.1-207; 22.1-207.1; 22.1-207.2; 22.1-208.01; 22.1-212.1:1; 22.1-213; 22.1-253.13:1; 22.1-253 et seq;22.1-253.13.1.D.5; 22.1-253.13:2; 22.1-253.13:1 et seq; 22.1-253.13:1.D.14; 22.1-253.13:3; 22.1-253.13:4; 22.1-254; 22.1-254(D); 22.1-254.2; 22.1-296.1; 22.1-296.2; 22.1-296.4; 46.2-335; 46.2-325; 46.3-334; 46.2-340; 54.1-2957.02.

Superintendent’s Memoranda No. 36 (Mar. 3, 2000) and No. 39 (Feb. 20, 2004).

Superintendent’s Memorandum No. 45 (Mar. 10, 2002).

Guidelines for Local School Boards to Award Verified Credits for the Standard Diploma to Transition Students (attachment to Virginia Department of Education Superintendent’s Memo No. 52 (Aug. 9, 2002), as amended by the Board of Education on Oct. 25, 2006.

Regulations Establishing Standards for Accrediting Public Schools in Virginia, Section 8 VAC 20131-50, Requirements for Graduation.

CROSS REFERENCES:

IA	Instructional Mission
IAA	Notification of Learning Objectives
IAA-E	District Syllabus
IBG	Homebound, Correspondence, and Alternative Means of Instruction
IC/ID	School Year/School Day
IE	Organization of Instruction
IF	Curriculum Development and Adoption
IGA	Basic Instructional Program
IGAD	Career and Technical Education
IGAE	Health Education/Physical Education

IGAG	Teaching about Drugs, Alcohol, and Tobacco
IGAH	Family Life Education
IGAI	Character Education
IGAJ	Driver Education
IGBA	Programs for Students with Disabilities
IGBB	Programs for Gifted Students
IGBB-R	Programs for Gifted Students
IGBGA	Online Courses and Virtual School Programs
IGBGA-R	Virtual Learning Program Handbook
IKA	Grading
IKF	Standards of Learning and Graduation Requirements
IKF-R	Diplomas and Certificates
IKFA	Locally Awarded Verified Credits
IKFD	Alternative Paths to Attaining Standard Units of Credit
JB	Equal Educational Opportunities and Non-Discrimination