

BASE BID WALLS & CEILINGS



Container Installation Guide

Panels and InSerts

The InSoFast CX Container panel and the InSerts are designed to fit most shipping containers. Containers have three types of corrugations: side wall, end wall, and ceiling. Refer to the container diagrams to determine if the InSoFast products will fit your container's corrugations. See Page 7.

Estimating

Side walls: CX Panel (5 panels/box) 36.67 s.f.

End wall: InSerts (20/box) 72 s.f. coverage
UX 2.0 or EX 2.5 (5 panels/box) 40 s.f.

Ceiling: InSerts (57/box) 160 s.f. coverage
UX 2.0 or EX 2.5 (5 panels/box) 40 s.f.

Floor: UX 2.0 or EX 2.5 (5 panels/box) 40 s.f.

Tools and Supplies

- Long snap off blade utility knife
- Saw – hand, jig, circular, or table saw
- Gap and crack foam for sealing corners/openings and at the top of the wall
- PL Premium 3x Construction Adhesive
 - 28 oz. tube covers 50 s.f. of InSoFast Panels
 - 28 oz. tube covers 50 s.f. of InSerts

Adhesive Considerations

- PL Premium 3x Construction Adhesive is the only recommended adhesive for adhering the InSoFast panels. Other formulas and brands may not work as expected.
- PL Premium 3x is a moisture-cured glue that takes as little as 24 hours to cure. Under cold or dry conditions, the adhesive will take longer to cure. If you are in a dry climate, you may want to lightly mist the panel with a spray bottle of water to expedite the curing process.
- PL Premium 3x is freeze-thaw stable but it does not cure during freezing temperatures. Even with heating the inside of the container, conditions outside the container will effect the cure time.
- It will be necessary to brace panels on the ceiling while the adhesive sets.
- Ensure adequate time for the adhesive to cure before attaching finished materials such as drywall and cabinets.



Container Preparation

If your container has large dented areas, we recommend hammering them as smooth as possible before your installing InSoFast products. As an alternative, you can remove foam to accommodate the dented area by scraping or cutting out the excess.

Eliminate any leaks before installing InSoFast panels. Do not penetrate the steel walls of your container with screws or fasteners. This compromises the continuous seal and can introduce moisture-related issues.

Ensure all surfaces are clean of any debris, dust, loose paint, etc before installing InSoFast panels. It is up to the installer to determine the suitability of the adhesive for the surface you are bonding to. An adhesive performance test can be done. See www.insofast.com for more details.

Installing CX Panels on the Side Walls

The InSoFast CX Container Panel is designed for the side walls of most shipping containers. The CX panels are set up for an 11" repeating pattern of the corrugation and the panel size is 44" x 24". They are installed horizontally with the studs running vertically.

Layout the first row of CX panels to determine the fit to the container. Variations in the corrugations may require the panels to be trimmed or spaced out slightly. If the panels need to be adjusted, it is best to then stack bond the panels instead of installing in a running bond pattern.

It is important to seal the bottom of the first row of panels. Apply a continuous bead of spray foam or adhesive along the bottom of the side wall of the container.

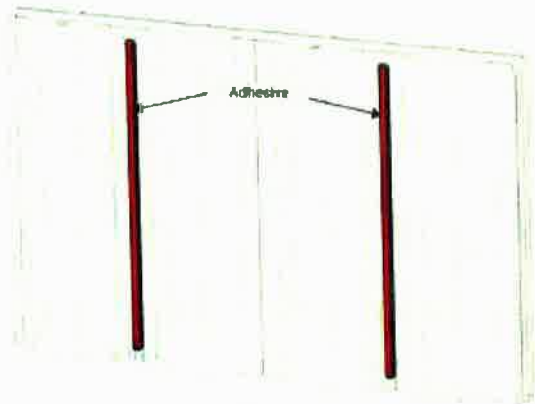

3/8" Bead of PL Premium

Place Adhesive on the backside of the panel

PL Premium 3x adhesive is applied in a 3/8" bead on the backside of the studs which have the ribbed surfaces. It is important that there is enough adhesive to squish into the dovetails on the back side of the stud when pressed to the container wall. To verify that enough adhesive is used, press the panel into place. Pull the panel back and check to see if the adhesive has spread out the width of the stud.

Since there is no stud at the cut ends of the panels, an additional bead of PL Premium 3x is applied at the start and end of each wall.

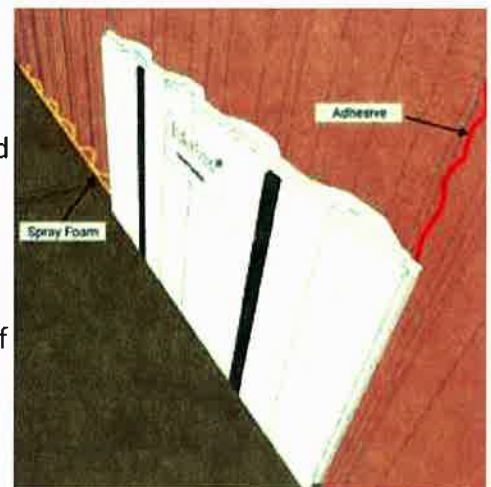

CX Panels fit the side wall corrugations

Install CX Panels in a running bond pattern

To start the second row, cut a panel in the center with a long snap off blade utility knife. This will start the running bond or staggered pattern.

At the top of the second row, run a bead of spray foam on the back side of the panel or directly on the container wall. We recommend sealing every 4' to prevent air movement.

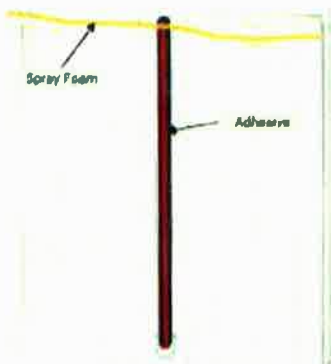

Spray foam along the top every 4'

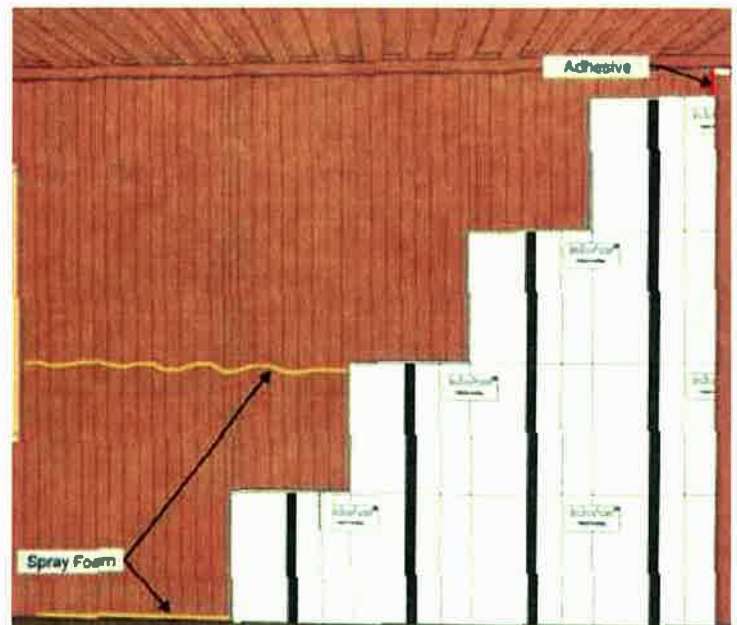

Install CX panels in a running bond pattern.

Installing UX 2.0 or EX 2.5 Panels on the End Wall

The End wall of the shipping container is insulated with End Wall InSerts and the UX 2.0 or EX 2.5 standard flat panel. These panels are 48" x 24" and are installed on end.

Install End Wall InSerts

Run a bead of PL Premium 3x along the length of the insert and press into the corrugated space of the shipping container's wall.

You can use duct tape to hold the InSerts in place until the adhesive has set or until you are ready to install the InSoFast panels. Position any duct tape so that it doesn't interfere with the stud bonding to the shipping container rib.

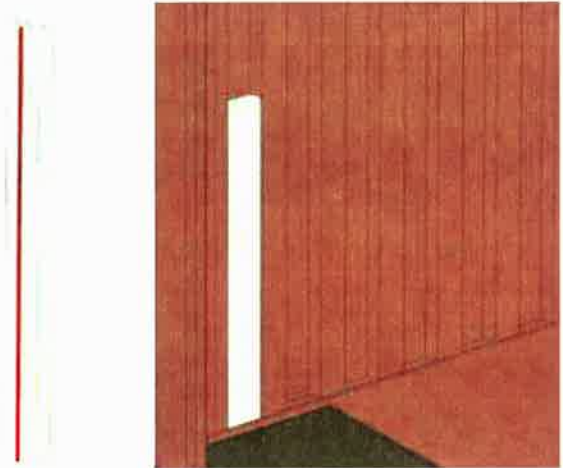

Adhesive on insert

Install InSerts

Install UX or EX Panels

Start with a continuous bead of spray foam or adhesive along the bottom of the end wall of the container.

Add a bead of PL Premium 3x in the corner where the first row of panels are placed.

We recommend installing panels standing on end with the embedded studs running perpendicular to a shipping container's corrugated ribs. The goal is to provide as much contact between the studs and steel in order to maximize the holding power of the studs.

You may want to trim the end of the UX or EX panel to "move" the stud down closer to the floor allowing baseboard to be attached.

For a standard 8' high container, the panels can be installed in a stacked method or a running bond pattern. The running bond pattern works well on a 9' high container. Use the cut off end of the top panel to start the next row.

On the back of the panel, run a 3/8" bead of adhesive along dove-tailed ribbing of each stud.

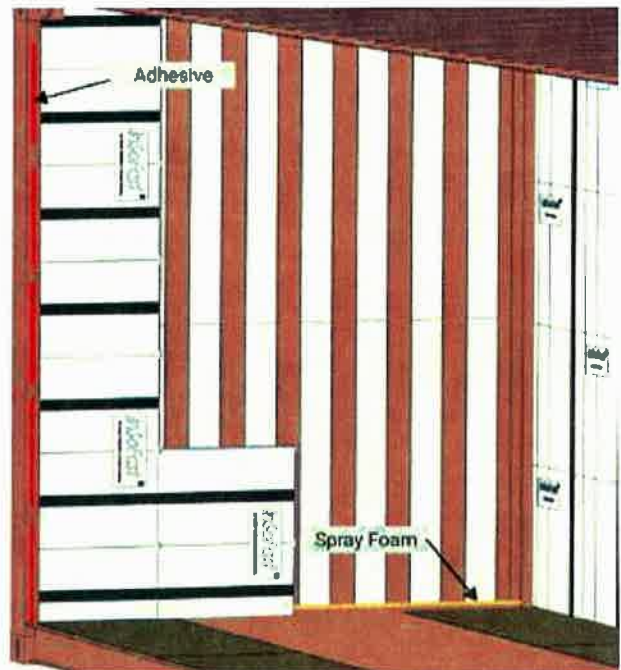

Install UX panels in a running bond pattern vertically.

Seal the corners with spray foam.

We do not recommend installing UX 2.0 or EX 2.5 panels without the InSerts. The InSerts are needed to prevent convecting looping behind the wall. If the end wall inserts are not used, seal the corrugation with spray foam at the 4' height to minimize the convective loop.

Installing UX 2.0 or EX 2.5 Panels on the Ceiling

The ceiling of the shipping container is insulated with Ceiling InSerts and the UX 2.0 or EX 2.5 standard flat panel. These panels are 48" x 24".

Install Ceiling InSerts

The ceiling inserts will need to be trimmed to fit the rounded ends of the corrugation. Use a long snap off blade utility knife.

Run a bead of PL Premium 3x adhesive along the length of the InSert and press into the corrugated space of the shipping container's ceiling.

You can use duct tape to hold the InSerts in place until the adhesive has set or until you are ready to install the InSoFast panels. Position any duct tape so that it doesn't interfere with the stud bonding to the shipping container rib.



Trim ceiling inserts. Apply adhesive.

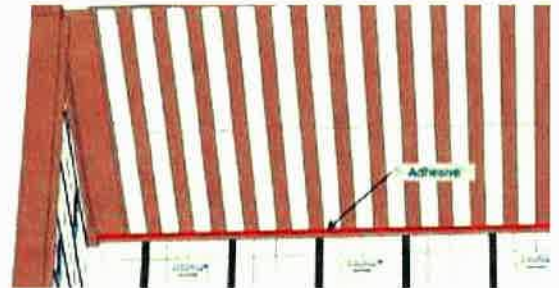

Run a bead of adhesive along the sides of the ceiling.

Install UX or EX Panels in a stacked pattern

We recommend installing panels with the embedded studs running perpendicular to a shipping container's corrugated rib. The goal is to provide as much contact between the studs and steel in order to maximize the holding power of the studs.

Add a bead of PL Premium 3x in the corner where the first row of panels are placed.

On the back of the panel, run a 3/8" bead of adhesive along dove-tailed ribbing of each stud.

Install the wall panels before the ceiling panels. This allows the ceiling panels to sit on top of the wall panels around the perimeter.

The running bond pattern is not required on the ceiling.

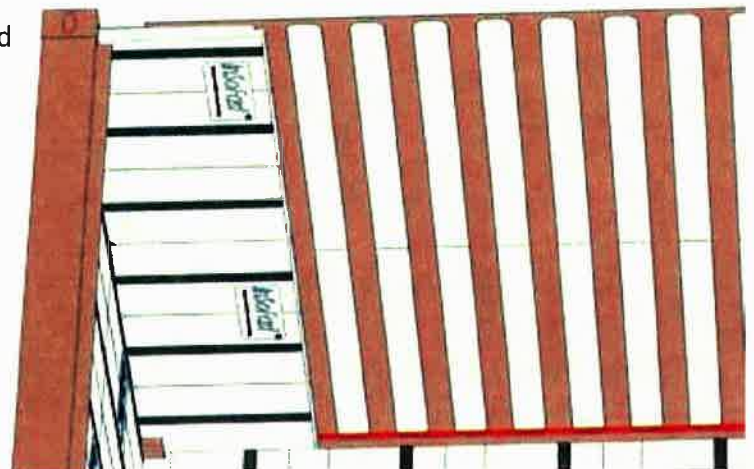

Install UX panels in a stack pattern.

Brace firmly until all adhesives has cured. The ceiling panels can be shimmed into place along the edges on top of the wall panels.

Seal the area between the ceiling and wall panels with spray foam.



Spray foam the gap between ceiling and walls

Installing UX 2.0 or EX 2.5 Panels on the Floor

The floor of the shipping container is insulated with the UX 2.0 or EX 2.5 standard flat panel. These panels are 48" x 24" and are installed in a running bond pattern.

Install the floor panels in the "floating" method without any adhesive. An alternative is to run a 3/8" bead of adhesive along dove-tailed ribbing of each stud and place the panels on the floor.

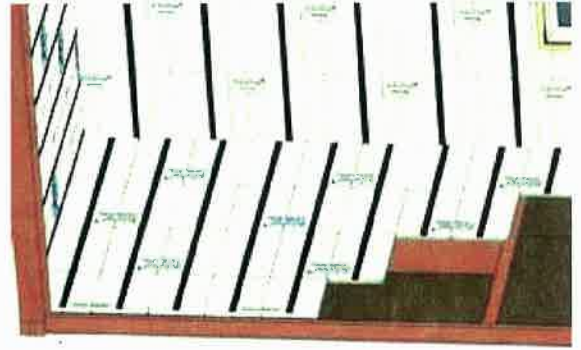

Install UX panels in a running bond pattern.

Subflooring should be installed so that the long seam of the plywood does not line up with the seams in the InSoFast panels. The short seams should butt together over top of a stud.

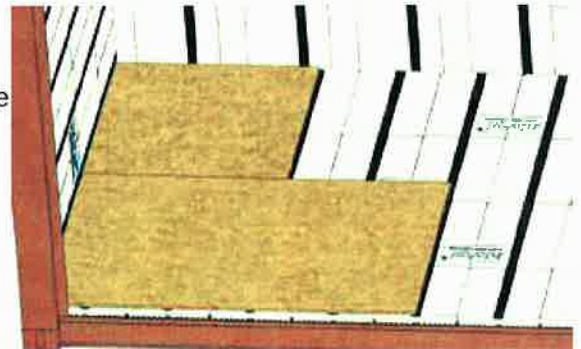

Make sure the long seam of the plywood does not line up with the InSoFast panels.

Sealing Gaps

Use spray foam to seal any gaps or cracks such as the area between the ceiling and the wall panels and around window/doors.

Need more insulation?

When higher R-values are required for the walls or ceilings, additional sheet foam can be added.

Install the InSoFast panels and simply tack or glue sheets of foam in place. Install drywall or other interior finishes using longer screws to penetrate at least 1/2" into the face of the InSoFast stud.

Electrical

Electrical Raceways are spaced horizontally every 24" o.c. and vertically every 22" o.c. as marked by a reference line on the face of the panels.

Cut out for the boxes.

Run wires through the raceways.

Use PL Premium 3x to glue the boxes in place.

Use spray foam to cover the wiring and fill the opening, satisfying the code requirement for wire attachment.



Electrical wiring coming out of box.

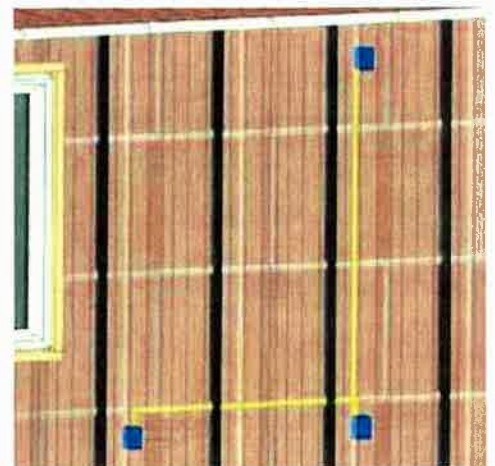

Vertical and horizontal wiring chases built in.

Installing Drywall over InSoFast Panels

It is not necessary to trim the drywall sheets to align on the InSoFast studs. Because the panels provide solid backing for the drywall you can float the butt seams between the studs. Use PL Premium 3x at the seams to bond the drywall to the panels.

On the end wall, install drywall vertically.



Windows/Doors

There are many methods for installing windows and doors. We will only be showing one method utilizing a wood jamb when a structural header is not required and InSoFast is only used on the interior. Whatever method you choose to you, the jambs or framing for any openings should be done before the InSoFast panels are installed.

Quick Wood Jamb Method

On a 2x4, mark the corrugation and cut apart. This creates the interior and exterior part of the bottom and top jamb. The side jambs are created in a similar manner, cutting lengthwise with a circular saw set to the angle of the container to accommodate the corrugation.

Use caulk and screws on each side to join the jambs together, sandwiching the container in between.

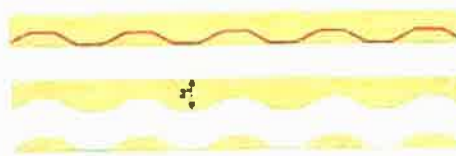

Cutting out the wood jamb.

The wood jamb should protrude inward 2" so that it will be flush with the InSoFast panels.

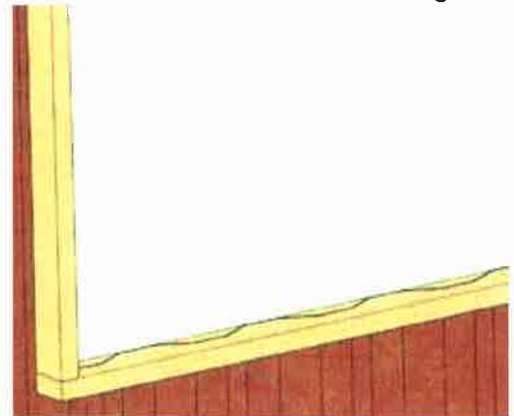

Wood jamb installed.

Flash, seal, and install the window per manufacturer's instructions.

Installing InSoFast Panels around Windows/Doors

An additional bead of PL Premium 3x is required around all openings to provide additional bonding around the cuts.

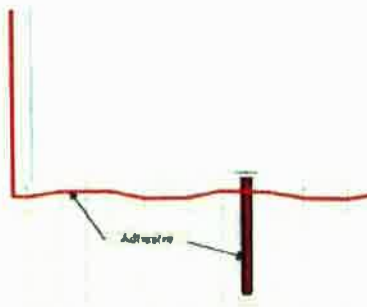

PL Premium on the studs and around the cut out. Spray foam on the top of the panel.

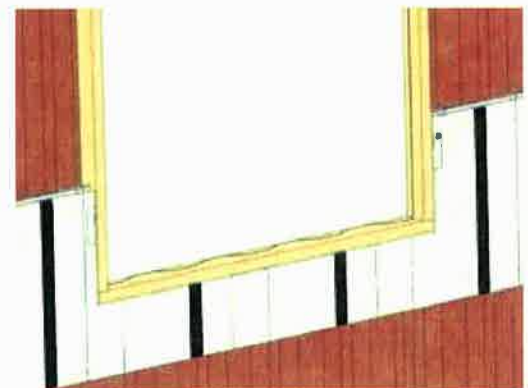

Leave a 1/4" gap for spray foam.

Sealing around Windows/Doors

Leave a 1/4" gap around all window/door openings so that after all the panels are installed, the gap can be filled with spray foam.

Indoor Air Quality (IAQ) and Preventing Moisture Issues

A shipping container provides the near perfect air tight "envelope". As with all Super energy efficient construction combined with near zero air infiltration the Heating ventilating and air-conditioning (HVAC) system must provide fresh air exchange and control latent moisture.

Container Specifications

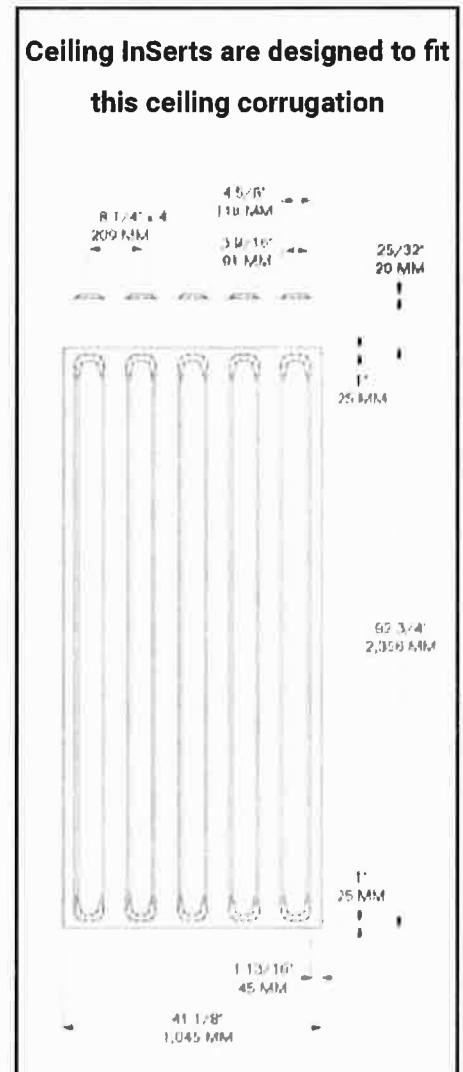
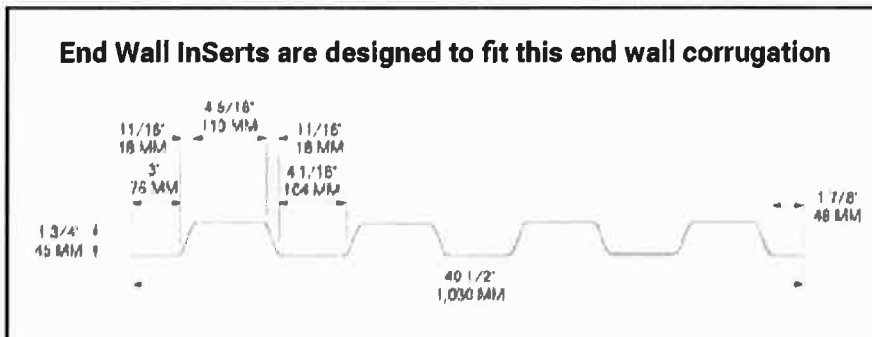
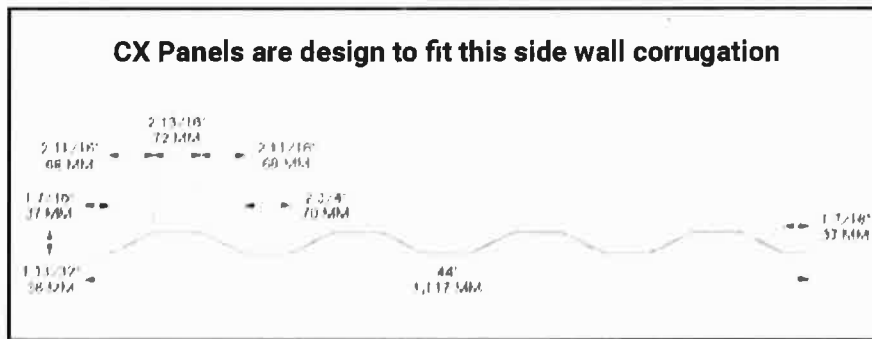

InSoFast LLC Limits of Liability and Disclaimer of Warranty:

Because use conditions and applicable laws may differ from one location to another and may change with time, Customer is responsible for determining whether products and the information in this document are appropriate for use and are in compliance with applicable laws and other government enactments. InSoFast LLC assumes no obligation or liability for the information in this document. NO WARRANTIES ARE GIVEN; ALL IMPLIED WARRANTIES OF MERCHANTABILITY OR FITNESS FOR A PARTICULAR PURPOSE ARE EXPRESSLY EXCLUDED. INSOFASFT LLC SHALL NOT BE RESPONSIBLE FOR CONSEQUENTIAL, INDIRECT OR INCIDENTAL DAMAGES (INCLUDING LOSS OF PROFITS) OF ANY KIND. InSoFast LLC reserves the right to make any changes according to technological progress or further developments and assumes no liability for providing such information and advice including the extent to which such information and advice may relate to existing third party intellectual property rights. Reference to trade names used by other companies is neither a recommendation, nor an endorsement of any product and does not imply that similar products could not be used. It is the responsibility of both the specifier and the purchaser to determine if a product is suitable for its intended use.