

**PROJECT MANUAL FOR
GLEN ARDEN ELEMENTARY SCHOOL ROOF-MOUNTED
PACKAGE UNIT REPLACEMENT**

RFP# 13-20

175 BINGHAM ROAD, ASHEVILLE, NORTH CAROLINA 28806

BID DATE: WEDNESDAY, MAY 6, 2020 at 4:00 pm EST

**TABLE OF CONTENTS FOR
GLEN ARDEN ELEMENTARY SCHOOL ROOF-MOUNTED
PACKAGE UNIT REPLACEMENT
RFP# 13-20**

Introduction

Title Page
Table of Contents

Procurement Forms

Request for Proposal – 16 pages

Specifications

Carrier RTU Submittal - 19 pages

**STATE OF NORTH CAROLINA/BUNCOMBE COUNTY SCHOOLS
REQUEST FOR PROPOSAL** **RFP# 13-20**

**PROJECT: GLEN ARDEN ELEMENTARY SCHOOL ROOF-MOUNTED PACKAGE UNIT
REPLACEMENT**

PROJECT DESIGNER: Gerald Isbouts, Project Manager

ISSUING AGENCY: Buncombe County Schools

ISSUE DATE: April 16, 2020

Sealed proposals subject to the conditions made a part hereof will be received until **4:00 pm EST on Wednesday, May 6, 2020** for furnishing all labor, materials, equipment, and services incidental and implied, for completion of the project described herein.

PRE-BID MEETING: A Pre-Bid meeting has been scheduled for Wednesday, April 22, 2020 at 9:30 am at Glen Arden Elementary, 50 Pinehurst Circle, Arden, NC 28704.

All visitors will meet/check-in at the front of the building outside. *DUE TO THE COVID-19 OUTBREAK, AND PER THE GOVERNOR'S EXECUTIVE ORDER, A MINIMUM OF 6 FEET OF SOCIAL DISTANCING WILL BE ENFORCED DURING THE MEETING*****

SEND ALL PROPOSALS DIRECTLY TO THE ADDRESS AS SHOWN BELOW:

Buncombe County Schools, Purchasing Division
askpurchasing@bcsemail.org

Direct inquiries concerning this RFP to: Gerald Isbouts, Project Manager Phone: (828) 225-1108
Jamie Messer, HVAC Supervisor Phone: (828) 225-1105
Tiffany McCants, Purchasing Officer Phone: (828) 255-5890

THE PROCUREMENT PROCESS

The following is a general description of the process by which a firm will be selected to provide services.

1. Request for Proposals (RFP) is issued to prospective contractors.
2. Proposals in one original will be received from each offeror in a sealed envelope or package. Each original shall be signed and dated by an official authorized to bind the firm. Unsigned proposals will not be considered.
3. All proposals must be received by the issuing agency no later than the date and time specified on the cover sheet of this RFP.
4. At that date and time the proposals from each responding firm will be opened. Interested parties are cautioned that these costs and their components are subject to further evaluation for completeness and correctness and therefore may not be an exact indicator of an offeror's pricing position. Proposals are confidential until such time that award has been made. Thereafter, the Purchasing Department will furnish a bid tab on the district's website.
5. Proposals will be evaluated according to completeness, content, experience with similar projects, ability of the offeror and its staff, and cost. Award of a contract to one offeror does not mean that the other proposals lacked merit, but that, all factors considered, the selected proposal was deemed most advantageous to Buncombe County Board of Education.
6. Offerors are cautioned that this is a request for offers, not a request to contract, and that Buncombe County Board of Education reserves the unqualified right to reject any and all offers when such rejection is deemed to be in its best interest.

(NOTE: THIS PAGE MUST BE FULLY EXECUTED AND RETURNED FOR CONSIDERATION OF PROPOSAL)

PROPOSAL FORM

**GLEN ARDEN ELEMENTARY SCHOOL ROOF-MOUNTED PACKAGE UNIT
REPLACEMENT**

RFP# 13-20

DUE DATE: Wednesday, May 6, 2020 at 4:00 pm EST

By submitting this proposal, the potential contractor certifies the following:

- ** This proposal is signed by an authorized representative of the firm.
- ** It can obtain and submit to the Owner insurance certificates as required within 5 calendar days after notice of award.
- ** The cost and availability of all equipment, materials, and supplies associated with performing the services described herein have been determined and included in the proposed cost.
- ** All labor costs, direct and indirect, have been determined and included in the proposed cost.
- ** All taxes have been determined and included in the proposed cost.
- ** The offeror has attended the conference (*if applicable*) or conducted a site visit and is aware of prevailing conditions associated with performing these services.
- ** The potential contractor has read and understands the conditions set forth in this RFP and agrees to them with no exceptions.

Therefore, in compliance with this Request for Proposals, and subject to all conditions herein, the undersigned offers and agrees, if this proposal is accepted within 60 days (normally less) from the date of the opening, to furnish the subject services for a cost not to exceed:

BASE BID: Provide turnkey project to replace a roof mounted 7-1/2 ton and a 28-ton package unit with curbs.

\$ _____ dollars and ____/100 (\$ _____).

Alternate #1: Provide additional 4-year warranty on parts and labor.

\$ _____ dollars and ____/100 (\$ _____).

Addenda received: _____ (Yes/No)

OFFEROR: _____

ADDRESS: _____

CITY, STATE, ZIP: _____

TELEPHONE NUMBER: _____ FAX: _____

FED ID No: _____ Type & License #: _____

E-MAIL: _____ MBE Status: _____

Principal Place of Business if different from above (See General Information on Submitting Proposals, Item 18.):

BY: (Signature) _____ TITLE: _____

DATE: _____ (Typed or printed name) _____

End of Proposal Form

GENERAL INFORMATION ON SUBMITTING PROPOSALS

1. **EXCEPTIONS:** All proposals are subject to the terms and conditions outlined herein. All responses shall be controlled by such terms and conditions and the submission of other terms and conditions, price lists, catalogs, and/or other documents as part of an offeror's response will be waived and have no effect either on this Request for Proposals or on any contract that may be awarded resulting from this solicitation. Offeror specifically agrees to the conditions set forth in the above paragraph by signature to the proposal.

78615644. **CERTIFICATION:** By executing the proposal, the signer certifies that this proposal is submitted competitively and without collusion (G.S. 143-54), that none of our officers, directors, or owners of an unincorporated business entity has been convicted of any violations of Chapter 78A of the General Statutes, the Securities Act of 1933, or the Securities Exchange Act of 1934 (G.S. 143-59.2), and that we are not an ineligible vendor as set forth in G.S. 143-59.1. False certification is a Class I felony.

78615645. **ORAL EXPLANATIONS:** The State/Buncombe County Schools shall not be bound by oral explanations or instructions given at any time during the competitive process or after award.

78615646. **REFERENCE TO OTHER DATA:** Only information which is received in response to this RFP will be evaluated; reference to information previously submitted shall not be evaluated.

78615647. **ELABORATE PROPOSALS:** Elaborate proposals in the form of brochures or other presentations beyond that necessary to present a complete and effective proposal are not desired.

In an effort to support the sustainability efforts of the State of North Carolina we solicit your cooperation in this effort.

It is desirable that all responses meet the following requirements:

- All copies are printed **double sided**.
- All submittals and copies are printed on **recycled paper with a minimum post-consumer content of 30%** and indicate this information accordingly on the response.
- Unless absolutely necessary, all proposals and copies should **minimize or eliminate use of non-recyclable or non re-usable materials** such as plastic report covers, plastic dividers, vinyl sleeves, and GBC binding. Three-ringed binders, glued materials, paper clips, and staples are acceptable.
- Materials should be submitted in a format which allows for **easy removal and recycling** of paper materials.

78615648. **COST FOR PROPOSAL PREPARATION:** Any costs incurred by offerors in preparing or submitting offers are the offerors' sole responsibility; the State of North Carolina/Buncombe County Schools will not reimburse any offeror for any costs incurred.

78615649. **TIME FOR ACCEPTANCE:** Each proposal shall state that it is a firm offer which may be accepted within a period of 45 days. Although the contract is expected to be awarded prior to that time, the 45-day period is requested to allow for unforeseen delays.

78615650. **TITLES:** Titles and headings in this RFP and any subsequent contract are for convenience only and shall have no binding force or effect.

78615651. **CONFIDENTIALITY OF PROPOSALS:** In submitting its proposal the offeror agrees not to discuss or otherwise reveal the contents of the proposal to any source outside of the using or issuing agency, government or private, until after the award of the contract. Offerors not in compliance with this provision may be disqualified, at the option of the State/Buncombe County Schools, from contract award. Only discussions authorized by the issuing agency are exempt from this provision.

78615652. **RIGHT TO SUBMITTED MATERIAL:** All responses, inquiries, or correspondence relating to or in reference to the RFP, and all other reports, charts, displays, schedules, exhibits, and other documentation submitted by the offerors shall become the property of the State/Buncombe County Schools when received.

78615653. **OFFEROR'S REPRESENTATIVE:** Each offeror shall submit with its proposal the name, address, and telephone number of the person(s) with authority to bind the firm and answer questions or provide clarification concerning the firm's proposal.

78615654. **SUBCONTRACTING:** Offerors may propose to subcontract portions of the work provided that their proposals clearly indicate what work they plan to subcontract and to whom and that all information required about the prime contractor is also included for each proposed subcontractor.

78615655. **PROPRIETARY INFORMATION:** Trade secrets or similar proprietary data which the offeror does not wish disclosed to other than personnel involved in the evaluation or contract administration will be kept confidential to the extent permitted by NCAC T01:05B.1501 and G.S. 132-1.3 if identified as follows: Each page shall be identified in boldface at the top and bottom as "CONFIDENTIAL". Any section of the proposal which is to remain confidential shall also be so marked in boldface on the title page of that section. Cost information may not be deemed confidential. In spite of what is labeled as confidential, the determination as to whether or not it is shall be determined by North Carolina law.

78615656. **HISTORICALLY UNDERUTILIZED BUSINESSES:** Pursuant to General Statute 143-48 and Executive Order #150, Buncombe County Schools invites and encourages participation in this procurement process by businesses owned by minorities, women, disabled, disabled business enterprises and non-profit work centers for the blind and severely disabled.

The Contractor agrees in particular to maintain open hiring and employment practices and to receive applications for employment in compliance with all requirements of applicable federal, state and local laws and regulations issued pursuant thereto relating to nondiscriminatory hiring and employment practices. Each Prime Contractor shall undertake an affirmative action program to ensure that no person shall be excluded from participation in any employment activities because of age, sex, race, religion, color, national origin or handicap.

78615657. **PROTEST PROCEDURES:** If an offeror wants to protest a contract awarded pursuant to this solicitation, they must submit a written request to the Purchasing Officer, Buncombe County Schools, 175 Bingham Road, or PO Box 16771, Asheville, NC 28806. This request must be received by the Purchasing Division within thirty (30) consecutive calendar days from the date of the contract award and must contain specific sound reasons and any supporting documentation for the protest. NOTE: Contract award notices are sent only to those actually awarded contracts, and not to every person or firm responding to this solicitation. Contract status and award notices are available through the purchasing division or the project designer with contact information as shown on the first page of this solicitation. Offerors may call to obtain a verbal status of contract award. All protests will be handled pursuant to the North Carolina Administrative Code, Title 1, Department of Administration, Chapter 5, Purchase and Contract, Section 5B.1519.

16. **TABULATIONS:** Offerors may visit the Buncombe County Schools website for bid tab details at www.buncombeschools.org/purchasing.

17. **VENDOR REGISTRATION AND SOLICITATION NOTIFICATION SYSTEM:** Vendor Link NC allows vendors to electronically register free with the State to receive electronic notification of current procurement opportunities for goods and services available on the Interactive Purchasing System. Online registration and other purchasing information are available on the Internet web site: <http://www.state.nc.us/pandc/>.

18. **RECIPROCAL PREFERENCE:** G.S. 143-59 establishes a reciprocal preference law to discourage other states from applying in-state preferences against North Carolina's resident offerors. The "Principal Place of Business" is defined as the principal place from which the trade or business of the offeror is directed or managed.

**NORTH CAROLINA GENERAL CONTRACT TERMS AND CONDITIONS
(Contractual and Consultant Services)**

1. **GOVERNING LAW:** This contract is made under and shall be governed and construed in accordance with the laws of the State of North Carolina.

78615732. **SITUS:** The place of this contract, its situs and forum, shall be North Carolina, where all matters, whether sounding in contract or tort, relating to its validity, construction, interpretation and enforcement shall be determined

78615733. **INDEPENDENT CONTRACTOR:** The Contractor shall be considered to be an independent contractor and as such shall be wholly responsible for the work to be performed and for the supervision of its employees. The Contractor represents that it has, or will secure at its own expense, all personnel required in performing the services under this agreement. Such employees shall not be employees of or have any individual contractual relationship with the Agency.

78615734. **KEY PERSONNEL:** The Contractor shall not substitute key personnel assigned to the performance of this contract without prior written approval by the Agency's Contract Administrator. The individuals designated as key personnel for purposes of this contract are those specified in the Contractor's proposal.

78615735. **SUBCONTRACTING:** Work proposed to be performed under this contract by the Contractor or its employees shall not be subcontracted without prior written approval of the Agency's Contract Administrator/Project Designer. Acceptance of an offeror's proposal shall include any subcontractor(s) specified therein.

78615736. **PERFORMANCE AND DEFAULT:** If, through any cause, the Contractor shall fail to fulfill in timely and proper manner the obligations under this agreement, the Agency shall thereupon have the right to terminate this contract by giving written notice to the Contractor and specifying the effective date thereof. In that event, all finished or unfinished deliverable items under this contract prepared by the Contractor shall, at the option of the Agency, become its property, and the Contractor shall be entitled to receive just and equitable compensation for any satisfactory work completed on such materials. Notwithstanding, the Contractor shall not be relieved of liability to the Agency for damages sustained by the Agency by virtue of any breach of this agreement, and the Agency may withhold any payment due the Contractor for the purpose of setoff until such time as the exact amount of damages due the Agency from such breach can be determined.
In case of default by the Contractor, the State may procure the services from other sources and hold the Contractor responsible for any excess cost occasioned thereby. The State reserves the right to require performance bond or other acceptable alternative guarantees from successful offeror without expense to the State.

Upon the entering of a judgment of bankruptcy or insolvency by or against the Contractor, the Agency may terminate this contract for cause.

Neither party shall be deemed to be in default of its obligations hereunder if and so long as it is prevented from performing such obligations by any act of war, hostile foreign action, nuclear explosion, riot, strikes, civil insurrection, earthquake, hurricane, tornado, or other catastrophic natural event or act of God.

78615737. **TERMINATION:** The Agency may terminate this agreement at any time by 15 days' notice in writing from the Agency to the Contractor. In that event, all finished or unfinished deliverable items prepared by the Contractor under this contract shall, at the option of the Agency, become its property. If the contract is terminated by the Agency as provided herein, the Contractor shall be paid for services satisfactorily completed, less payment or compensation previously made.

78615738. **AVAILABILITY OF FUNDS:** Any and all payments to the Contractor are dependent upon and subject to the availability of funds to the Agency for the purpose set forth in this agreement.

78615739. **CONFIDENTIALITY:** Any information, data, instruments, documents, studies or reports given to or prepared or assembled by the Contractor under this agreement shall be kept as confidential and not divulged or made available to any individual or organization without the prior written approval of the Agency.

78615740. **CARE OF PROPERTY:** The Contractor agrees that it shall be responsible for the proper custody and care of any property furnished it for use in connection with the performance of this contract or purchased by it for this contract and will reimburse the State for loss of damage of such property.

78615741. **COPYRIGHT:** No deliverable items produced in whole or in part under this agreement shall be the subject of an application for copyright by or on behalf of the Contractor.

78615742. **ACCESS TO PERSONS AND RECORDS:** The State Auditor shall have access to persons and records as a result of all contracts or grants entered into by State agencies or political subdivisions in accordance with General Statute 147-64.7.
The Contractor shall retain all records for a period of three years following completion of the contract.

78615743. **ASSIGNMENT:** No assignment of the Contractor's obligations nor the Contractor's right to receive payment hereunder shall be permitted. However, upon written request approved by the issuing purchasing authority, the State may:

- a. Forward the contractor's payment check(s) directly to any person or entity designated by the Contractor, or
- b. Include any person or entity designated by Contractor as a joint payee on the Contractor's payment check(s).

In no event shall such approval and action obligate the State to anyone other than the Contractor and the Contractor shall remain responsible for fulfillment of all contract obligations.

78615744. **COMPLIANCE WITH LAWS:** The Contractor shall comply with all laws, ordinances, codes, rules, regulations, and licensing requirements (permits) that are applicable to the conduct of its business, including those of federal, state, and local agencies having jurisdiction and/or authority.

78615745. **AFFIRMATIVE ACTION:** The Contractor shall take affirmative action in complying with all Federal and State requirements concerning fair employment and employment of people with disabilities and concerning the treatment of all employees without regard to discrimination by reason of race, color, religion, sex, national origin, or disability.

78615746. **INSURANCE:** During the term of the contract, the contractor at its sole cost and expense shall provide commercial insurance of such type and with such terms and limits as may be reasonably associated with the contract. As a minimum, the contractor shall provide and maintain the following coverage and limits:

- a. Workers Compensation - The contractor shall provide and maintain Worker's Compensation Insurance, as required by the laws of North Carolina, as well as employer's liability coverage with minimum limits of \$150,000.00, covering all of Contractor's employees who are engaged in any work under the contract. If any work is subcontracted, the contractor shall require the subcontractor to provide the same coverage for any of its employees engaged in any work under the contract.
- b. Commercial General Liability - General Liability Coverage on a Comprehensive Broad Form on an occurrence basis in the minimum amount of \$2,000,000.00 Combined Single Limit. (Defense cost shall be in excess of the limit of liability).
- c. Automobile - Automobile Liability Insurance, to include liability coverage, covering all owned, hired and non-owned vehicles, used in connection with the contract. The minimum combined single limit shall be \$500,000.00 bodily injury and property damage; \$500,000.00 uninsured/underinsured motorist; and \$100,000.00 medical payment.

Providing and maintaining adequate insurance coverage is a material obligation of the contractor and is of the essence of this contract. All such insurance shall meet all laws of the State of North Carolina. Such insurance coverage shall be obtained from companies that are authorized to provide such coverage and that are authorized by the Commissioner of Insurance to do business in North Carolina. The contractor shall at all times comply with the terms of such insurance policies, and all requirements of the insurer under any such insurance policies, except as they may conflict with existing North Carolina laws or this contract. The limits of coverage under each insurance policy maintained by the contractor shall not be interpreted as limiting the contractor's liability and obligations under the contract.

The Contractor shall furnish a Certificate of Insurance as proof of the above coverages. Certificate will contain provision that the insurance coverages cannot be canceled, reduced in amount or coverage eliminated without 30 days written notice to the Buncombe County Board of Education. Owner's Protective insurance must list the Buncombe County Board of Education as the Certificate Holder and as "additional insured" as it's interest may appear. Owner's approval of Certificate of Insurance does not decrease or relieve the contractor's responsibility for maintaining insurance coverage as required in this Request for Proposal.

78615747. **ADVERTISING:** Contractor agrees not to use the existence of this contract, the name of the agency, or the name of the State of North Carolina as part of any commercial advertising.

78615748. **ENTIRE AGREEMENT:** This contract and any documents incorporated specifically by reference represent the entire agreement between the parties and supersede all prior oral or written statements or agreements. This Request for Proposals, any addenda thereto, and the offeror's proposal are incorporated herein by reference as though set forth verbatim.

All promises, requirements, terms, conditions, provisions, representations, guarantees, and warranties contained herein shall survive the contract expiration or termination date unless specifically provided otherwise herein, or unless superseded by applicable Federal or State statutes of limitation.

78615749. **AMENDMENTS:** This contract may be amended only by written amendments duly executed by the Agency and the Contractor.

78615750. **TAXES:** G.S. 143-59.1 bars the Secretary of Administration from entering into contracts with vendors if the vendor or its affiliates meet one of the conditions of G. S. 105-164.8(b) and refuse to collect use tax on sales of tangible personal property to purchasers in North Carolina. Conditions under G. S. 105-164.8(b) include: (1) Maintenance of a retail establishment or office, (2) Presence of representatives in the State that solicit sales or transact business on behalf of the vendor and (3) Systematic exploitation of the market by media-assisted, media-facilitated, or media-solicited means. By execution of the bid document the vendor certifies that it and all of its affiliates, (if it has affiliates), collect(s) the appropriate taxes.

78615751. **GENERAL INDEMNITY:** The contractor shall hold and save the State/Buncombe County Schools, its officers, agents, and employees, harmless from liability of any kind, including all claims and losses, with the exception of consequential damages, accruing or resulting to any other person, firm, or corporation furnishing or supplying work, services, materials, or supplies in connection with the performance of this contract, and from any and all claims and losses accruing or resulting to any person, firm, or corporation that may be injured or damaged by the contractor in the performance of this contract and that are attributable to the negligence or intentionally tortious acts of the contractor provided that the contractor is notified in writing within 30 days that the State/Buncombe County Schools has knowledge of such claims. The contractor represents and warrants that it shall make no claim of any kind or nature against the State's agents who are involved in the delivery or processing of contractor goods to the State. The representation and warranty in the preceding sentence shall survive the termination or expiration of this contract.

CONTRACTOR'S SALES TAX REPORT Buncombe County Schools

NC State and Local Sales Taxes Paid

CONTRACTOR: _____ PO#/RFP# 13-20_____

Address: _____ For Period: _____

Invoice Date	Invoice #	Type of Property	NC Tax 4.75%	County Tax 2.25%	Name of County
		TOTAL	\$	\$	

I certify that the above figures do not include any tax paid on supplies, tools and equipment which were used to perform this contract and only includes those building materials, supplies, fixtures and equipment which actually became a part of or annexed to the building or structure, and all of the required sales and use tax have been paid. I certify that, to the best of my knowledge, the information provided here is true, correct, and complete.

Sworn to and subscribed before me,

This the _____ day of _____, 20_____

Signed

Notary Public

My Commission Expires: _____

Print or Type Name of Above & Title

Seal

NOTE:
This certified statement may be subject to audit.

The North Carolina General Assembly has amended the Statute to provide refunds of sales and use tax to local school units in accordance with the provisions of G.S. 105-164. 14(c) effective with tax paid on or after July 1, 1998.

These refunds are to include the “sales and use taxes paid by contractors on building materials, supplies, fixtures and equipment that become a part of or annexed to a building or structure that is owned or leased by the governmental entity and is being erected, altered or repaired for use by the governmental entity (G.S. 105-164.14).”

Sales and Use Tax Technical Bulletin Section 18-2F specifies: “To substantiate a refund claim for sales or use taxes paid on purchases of building materials, supplies, fixtures and equipment by its contractor, the claimant must secure from such contractor certified statements setting forth all of the following information:

- a. the date the property was purchased;
- b. the type of property purchased;
- c. the project for which the property was used;
- d. if the property was purchased in this State, the county in which it was purchased;
- e. if the property was not purchased in this State, the county in which the property was used; and
- f. the amount of sales and use taxes paid.

In the event the contractor makes several purchases from the same vendor, such certified statement must indicate the invoice numbers, the inclusive dates of the invoices, the total amount of the invoices and the State and local sales and use taxes paid thereon. Such statement must also include the cost of any tangible personal property withdrawn from the contractor's warehouse stock and the amount of sales and use tax paid thereon by the contractor. Similar certified statements by his subcontractors must be obtained by the general contractor and furnished to the claimant. Any local sales or use taxes must be shown separately from the State sales or use taxes. The contractor's statements must not contain sales or use taxes paid on purchases of tangible personal property purchased by such contractors for use in performing the contract which does not annex to, affix to or in some manner become a part of the building or structure that is owned or leased by a governmental agency and is being erected, altered or repaired for use by a governmental entity as defined by G.S. 105-164.14(c). Examples of property on which sales or use tax has been paid by the contractor and which shall not be included in the contractor's statement are scaffolding, forms for concrete, fuel for the operation of machinery and equipment, tools, repair parts and equipment rentals.

All information requested in these specifications and actual bids shall be entered on enclosed “Request for Proposal” All areas of this document must be completed in full, especially: (1) Name of Company, (2) By (signature), (3) Official Title, and (4) Quotation Date.

**GLEN ARDEN ELEMENTARY SCHOOL ROOF-MOUNTED PACKAGE UNIT
REPLACEMENT
RFP# 13-20**

Project Description: Furnish all labor, materials, equipment and services, incidental and implied, for the removal of the (2) electric package units and replace with new gas fired package units. The 7-1/2-ton unit design is based on the carrier model 48HCRE08K3M6-2F2C0. The 28-ton unit is based on the carrier model 48HCRE28KCM6-2F2C0. Complete specifications are attached on separate spec sheet in this bid package. Some specification details are listed below, under Scope.

Scope: Work shall consist of furnishing all labor, taxes, materials, equipment, services, permits and startup, incidental and implied, to install a complete working system as designed per the attached specifications.

1. Remove the (2) existing electric roof mounted units.
2. Install metal curb adaptors.
3. Install new replacement units as specified with BACnet capability.
4. Extend and properly size metal gas piping to accommodate new units. Pipes shall be painted yellow and labeled) Valves shall be included.
5. All wiring, accessories and disconnects shall be replaced and included.
6. All low voltage wiring shall be in conduit.
7. DDC controls shall be performed by Trane. (Fred VanAller 828 337-4297)
8. Factory Start-up, Adjustment test report shall be part of this contract. Three copies of the completed factory start-up sheet, installation, operation and maintenance manuals shall be delivered to the owner before final payment will be made.
9. All old equipment, piping and wiring shall be removed.

SPECIFICATIONS:

The complete spec sheet for this system is included in this bid package.

A summary of the units is listed below:

- 28-ton package unit model: 48HCRE28KCM6-2F2C0

Unit Parameters:

Unit Model: **48HCRE28KCM6-2F2C0**

Unit Size: **28 (25 Tons)**

Volts-Phase-Hertz: **460-3-60**

Heating Type: **Gas**

Duct Cfg: **Vertical Supply / Vertical Return**

Stainless Steel, Medium Heat

Two stage Cooling with Humidi-MiZer™

Dimensions (ft. in.) & Weight (lb.) ***

Unit Length: **13' 1.75"**

Unit Width: **7' 2.375"**

Unit Height: **4' 9.375"**

***** Total Operating Weight: 2976 lb**

*** Weights and Dimensions are approximate. Weight does not include unit packaging. Approximate dimensions are provided primarily for shipping purposes. For exact dimensions and weights, refer to appropriate product data catalog. Contractor is responsible for onsite measuring.

Lines and Filters

Gas Line Size: **3/4**

Condensate Drain Line Size: **3/4**

Return Air Filter Type: **Throwaway**

Return Air Filter Quantity: **9**

Return Air Filter Size: **16 x 25 x 2**

Unit Configuration

Condensate Overflow Switch and RA Smoke Detectors

High Static Option with High Efficiency Motor - Vertical Models Al/Cu - Al/Cu - Louvered Hail Guard

RTU Open Controller

Enthalpy Economizer w/ Barometric Relief. Vertical and Horizontal Air Flow. Powered Convenience Outlet

Non-Fused Disconnect Standard Packaging

Humidi-MiZer™ Adaptive Dehumidification System

Warranty Information

1-Year parts(std.)

5-Year compressor parts (std.)

15-Year heat exchanger - Stainless Steel (std.)

- 7-1/2-ton package unit model 48HCRE08K3M6-2F2C0

Unit Parameters:

Unit Model: **48HCRE08K3M6-2F2C0**

Unit Size: **08 (7.5 Tons)**

Volts-Phase-Hertz: **460-3-60**

Heating Type: **Gas**

Duct Cfg: **Vertical Supply / Vertical Return**

Stainless Steel, Medium Heat

Two stage cooling models with Humidi-MiZer

Dimensions (ft. in.) & Weight (lb.) ***

Unit Length: **7' 4.125"**

Unit Width: **4' 11.5"**

Unit Height: **4' 1.375"**

***** Total Operating Weight: 1205 lb**

*** Weights and Dimensions are approximate. Weight does not include unit packaging. Approximate dimensions are provided primarily for shipping purposes. For exact dimensions and weights, refer to appropriate product data catalog. Contractor is responsible for onsite measuring.

Lines and Filters

Gas Line Size: **1/2**

Condensate Drain Line Size: **3/4**

Return Air Filter Type: **Throwaway**

Return Air Filter Quantity: **4**

Return Air Filter Size: **20 x 20 x 2**

Unit Configuration

Condensate Overflow Switch and RA Smoke Detectors

High Static Option - Belt Drive

Al/Cu - Al/Cu - Louvered Hail Guards

RTU Open Controller

Enthalpy Economizer w/ Barometric Relief

Powered Convenience Outlet

Non-Fused Disconnect Standard Packaging

Humidi-MiZer™ Adaptive Dehumidification System

Warranty Information

1-Year parts

5-Year compressor parts

15-Year heat exchanger - Stainless Steel

Contractor's Responsibility: The Contractor shall be responsible for the construction site during the performance of the work. The Contractor shall be responsible for all damages to persons and property during the performance of work and shall further provide all necessary safety measures and shall fully comply with all federal state and local laws, building rules, and regulations to prevent accidents or injury to persons or property on or about the location of the work site. This is to include OSHA 1910, General Construction, or those regulations mandated by these specifications. Special attention shall be made to proper barricading of the work area.

Safety Regulations: The Contractor shall adhere to the rules, regulations and interpretations of the North Carolina Department of Labor relating to Occupational Safety and Health Standards for the Construction Industry (Title 29, Code of Federal Regulations, Part 1926, published in Volume 39, Number 122, Part II, June 24, 1974 Federal Register) which is hereby incorporated in these specifications.

Codes: All work shall be performed in accordance with the specifications and shall comply with North Carolina Building Code, National Electrical Code Underwriters' Rules and Regulations and Federal, State and Local Regulations covering work of this nature. Whenever specifications are more than such laws, codes and regulations, the specifications shall hold. All equipment shall have U. L. labels attached.

Permits: The Contractor shall hold the appropriate license for work to be performed and shall secure all permits required for the job completion, obtain and deliver to Owner, all certification of inspection issued by the authorities having jurisdiction and roofing material manufacturer. Contractor is responsible for paying all costs associated with Buncombe County building permits. All final certificates must be delivered to owner prior to request for final payment.

School Security and Access: Security, safety and protection of the instructional environment are priority concerns of Buncombe County Schools. The Contractor shall confine activities to the work area and shall not engage or interact with students, teachers or staff that is not designated as contact personnel. The Contractor shall screen all employees on-site; and, at the request of the Owner, provide documentation that employees and subcontractors meet standards. The Owner, school staff and Contractor shall designate contact personnel and provide contact information to assist in the resolution of any logistical or safety issues beforehand, or that may arise during construction.

Scheduling: The Contractor must submit a precise time schedule as to when specific work will occur in specific areas within the building. This will be used to coordinate the work with the occupants of the building. The Maintenance Supervisor, Project manager or Principal may alter the schedule at any time to maintain the work process within the facility. Work must be scheduled during hours that are acceptable to each school and the Buncombe County Board of Education shall not incur any additional cost due to scheduling.

All work must be scheduled to avoid conflict with classroom instruction time and Cafeteria operation times. Project should be completed **by August 1, 2020**. All permits and inspections will be the responsibility of the contractor, and copies of permits and final inspection will be submitted to Buncombe County Schools prior to final payment.

Workers on Job: All employees of the Contractor shall, while on Buncombe County Board of Education property, act in a professional and courteous manner. All workers shall be expected to wear long pants and shirts while on Board property. Also, all employees of the Contractor must "sign in" in the main office upon entering the facility and must "sign out" upon leaving the property. Any employee of the Contractor may be told to leave the property by either the Principal or the Electrical Supervisor, if they do not follow the above procedure. The employee shall be replaced with another at no additional cost to the Buncombe County Board of Education. Smoking or use of Tobacco products is prohibited on Buncombe County School's property.

In accordance with G.S. 14-208.18, all persons who (1) are required to register under the Sex Offender and Public Protection Program AND (2) have been convicted of certain sexually violent offenses or any offense where the victim was under the age of 16 years at the time of the offense are expressly forbidden to knowingly be present on any property owned or operated by the school system, including school buildings, athletic fields, playgrounds, parking lots, school buses, activity buses or other property of any kind for any reason, including attendance at sporting events or other school related functions, whether before, during or after school hours. It is the responsibility of the Contractor or vendor that their employees and sub-contractors are in accordance with G.S. 14-208.18.

E-Verify: Contractor shall comply with E-Verify, the federal E-Verify program operated by the United States Department of Homeland Security and other federal agencies, or any successor or equivalent program used to verify the work authorization of newly hired employees pursuant to federal law and as in accordance with N.C.G.S. §64-25 et seq. In addition, to the best of Contractor's knowledge, any subcontractor employed by Contractor as a part of this contract shall be in compliance with the requirements of E-Verify and N.C.G.S. §64-25 et seq.

Iran Divestment Act: North Carolina Local Government Units may not enter into contracts with any entity or individual found on the State Treasurer's Iran Final Divestment List N.C.G.S. 143C-6A. By bidding on this project, the bidder certifies it is not listed on the Final Divestment List created by the State Treasurer.

Equipment and Tools: The Contractor shall not use equipment or tools that are owned by the Buncombe County Board of Education. Also, employees of the Buncombe County Board of Education shall not be utilized by the Contractor except for opening locked doors and giving directions.

Materials: All materials stored on site must be stored in a safe and secure manner that does not interfere with the school's daily operation. Buncombe County Board of Education is not responsible for any materials, equipment or tools lost or stolen from the site.

Clean Up: The area of work shall be cleaned daily so that the Buncombe County Board of Education shall not incur any additional costs to make the area suitable for the work process. Also, the Contractor shall utilize no trash receptacles or dumpsters owned by the Buncombe County Board of Education. All trash and removed materials shall be properly disposed of off the property. Onsite dumpsters shall not be used.

Changes during project: Changes during the project shall only be made by written direction signed by the owner. No additional cost to the contract shall be allowed unless accepted in writing by the owner before work has begun.

Price Adjustments:(Term Contracts Only) Any price changes, downwards or upward, which might be permitted during the contract period must be general, either by reason of market change or on the part of the contractor to the other customers.

a. **Notification:** Must be given to Buncombe County Schools, in writing, concerning any proposed price adjustments. Such notification shall be accompanied by copy of manufacturer's official notice or other acceptable evidence that the change is general in nature.

b. **Decreases:** Buncombe County Schools shall receive full proportionate benefit immediately at any time during the contract.

c. **Increases: Consumer Price Index (CPI):** Contract prices for equipment and/or service will remain firm through June 30, 2020. Contractors must request price adjustments, in writing, 30 days prior to the renewal date. If a Contractor fails to request CPI price adjustment 30 days prior to the adjustment date, the adjustment will be effective 30 days after Buncombe County Schools receives their written request. Price adjustments will be made in accordance with the percentage change in the U.S. Department of Labor Consumer Price Index (CPI-U) for all urban consumers, all items, southern region.

The price adjustment rate will be determined by comparing the percentage difference between the CPI in effect for the base yearly average (January through December beginning the year 2020); and each (January through December) thereafter. The percentage difference between those two CPI issues will be the price adjustment rate. No retroactive contract price adjustments will be allowed. All bidders will be capped with a 3% maximum price increase.

d. **Invoices:** It is understood and agreed that orders will be shipped at the established contract prices in effect on dates orders are placed. Invoicing at variance with this provision will subject the contract to cancellation. Applicable North Carolina sales tax shall be invoiced as a separate item.

Payment: Progress payments will be made for this project.

Final documents required:

1. Letter to the project manager from contractor which states all work is completed and payment is desired.
2. Delivery to owner, copies of all permits, certifications of inspection issued by the authorities having jurisdiction

Performance of Work: All work shall be performed at the highest level of quality. The Owner shall be responsible for determining the quality of work and may notify the Contractor of same. ANY WORK COMPLETED THAT IS NOT SUITABLE TO THE OWNER SHALL BE REPEATED BY THE CONTRACTOR AT NO COST TO THE OWNER. Any damage to existing area or utilities will be the responsibility of the Contractor. NO EXCEPTIONS.

Warranty: All labor, material and equipment shall be warranted for one (1) years from issuance of inspection.

Contractor must adhere to the guidelines within these specifications; failure to do so will result in default of payment by the BCBOE and/or cancelation of this contract.

The Buncombe County Board of Education reserves the right to reject any or all bids or any or no reason.

End of RFP# 13-20



SUBMITTAL

Project

Glen Arden Elementary

Date

Wednesday, December 4, 2019

Table Of Contents

Project: Glen Arden Elementary
Prepared By:

12/04/2019
08:38AM

Existing 50TJ028	3
Unit Report.....	4
Certified Drawing.....	5
Performance Summary.....	9
Existing 50TJQ008	12
Unit Report.....	13
Certified Drawing.....	14
Performance Summary.....	17

Existing 50TJ028

Project: Glen Arden Elementary
Prepared By:

12/04/2019
08:38AM

Existing 50TJ028

Tag Cover Sheet Unit Report Certified Drawing Performance Report

Unit Report For Existing 50TJ028

Project: Glen Arden Elementary
 Prepared By:

12/04/2019
 08:38AM

Unit Parameters

Unit Model:.....**48HCRE28KCM6-2F2C0**
 Unit Size:.....**28 (25 Tons)**
 Volts-Phase-Hertz:.....**460-3-60**
 Heating Type:.....**Gas**
 Duct Cfg:.....**Vertical Supply / Vertical Return**
 Stainless Steel, Medium Heat
 Two stage Cooling with Humidi-MiZer

Dimensions (ft. in.) & Weight (lb.) ***

Unit Length:.....**13' 1.75"**
 Unit Width:.....**7' 2.375"**
 Unit Height:.....**4' 9.375"**
 *** Total Operating Weight:.....**2976 lb**

*** Weights and Dimensions are approximate. Weight does not include unit packaging. Approximate dimensions are provided primarily for shipping purposes. For exact dimensions and weights, refer to appropriate product data catalog.

Lines and Filters

Gas Line Size:.....**3/4**
 Condensate Drain Line Size:.....**3/4**
 Return Air Filter Type:.....**Throwaway**
 Return Air Filter Quantity:.....**9**
 Return Air Filter Size:.....**16 x 25 x 2**

Unit Configuration

Condensate Overflow Switch and RA Smoke Detectors
 High Static Option with High Efficiency Motor - Vertical Models
 Al/Cu - Al/Cu - Louvered Hail Guard
 RTU Open Controller
 Enthalpy Economizer w/ Barometric Relief. Vertical and Horizontal Air Flow.
 Powered Convenience Outlet
 Non-Fused Disconnect
 Standard Packaging
 Humidi-MiZer™ Adaptive Dehumidification System

Warranty Information

1-Year parts(std.)
 5-Year compressor parts(std.)
 15-Year heat exchanger - Stainless Steel(std.)

No optional warranties were selected.

NOTE: Please see Warranty Catalog 500-089 for explanation of policies and ordering methods.

Ordering Information

Part Number	Description	Quantity
48HCRE28KCM6-2F2C0	Rooftop Unit	1
	Base Unit	
	Condensate Overflow Switch and RA Smoke Detectors	
	High Static Option with High Efficiency Motor - Vertical Models	
	Al/Cu - Al/Cu - Louvered Hail Guard	
	Powered Convenience Outlet	
	RTU Open controls Low leak Enty. Econo 2 with baro relief. Meets Calf. Title 24 FDD	
	Non-Fused Disconnect	

Certified Drawing for Existing 50TJ028

Project: Glen Arden Elementary
Prepared By:

12/04/2019
08:38AM

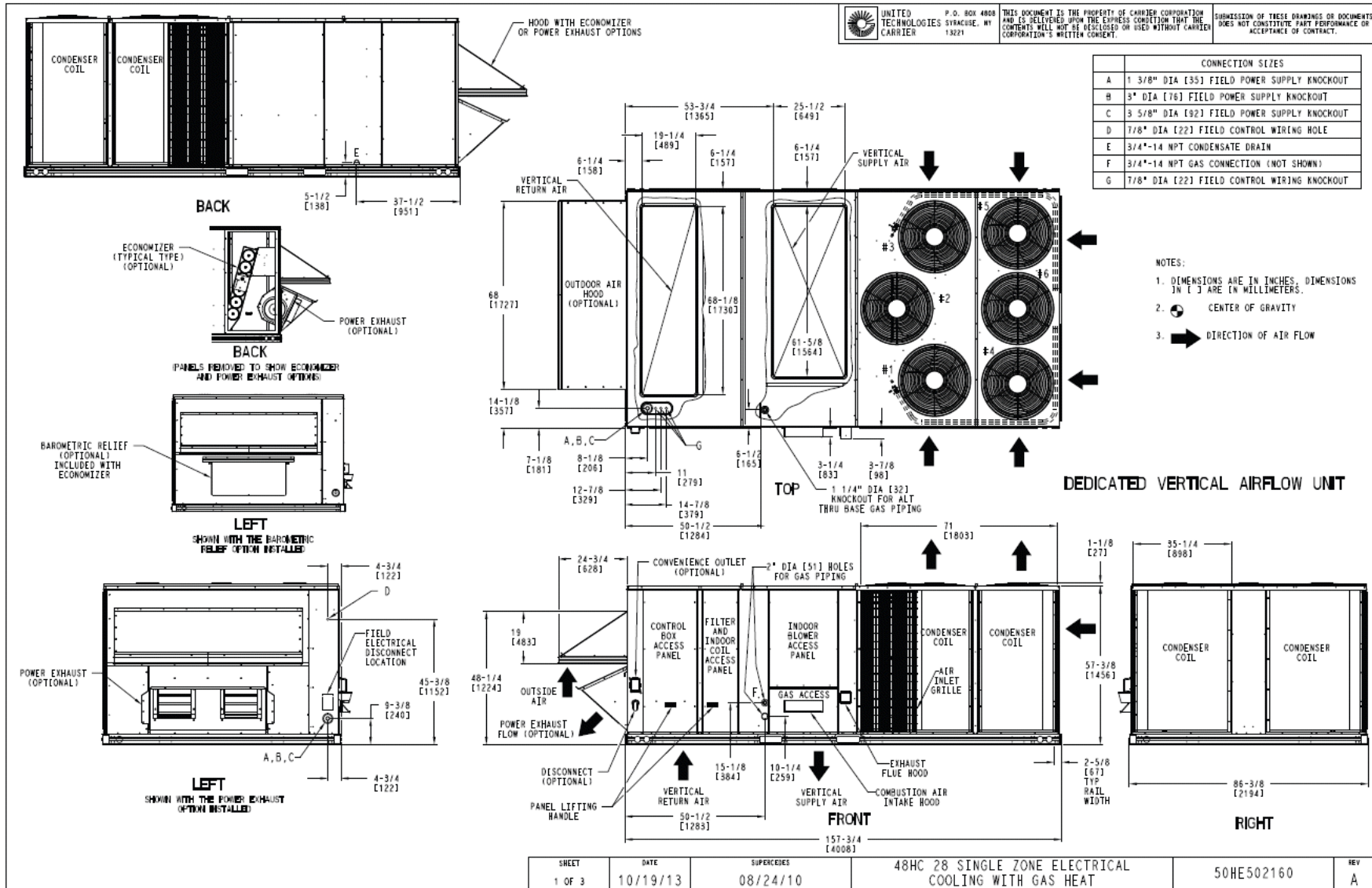

Certified Drawing for Existing 50TJ028

Project: Glen Arden Elementary
Prepared By:

12/04/2019
08:38AM

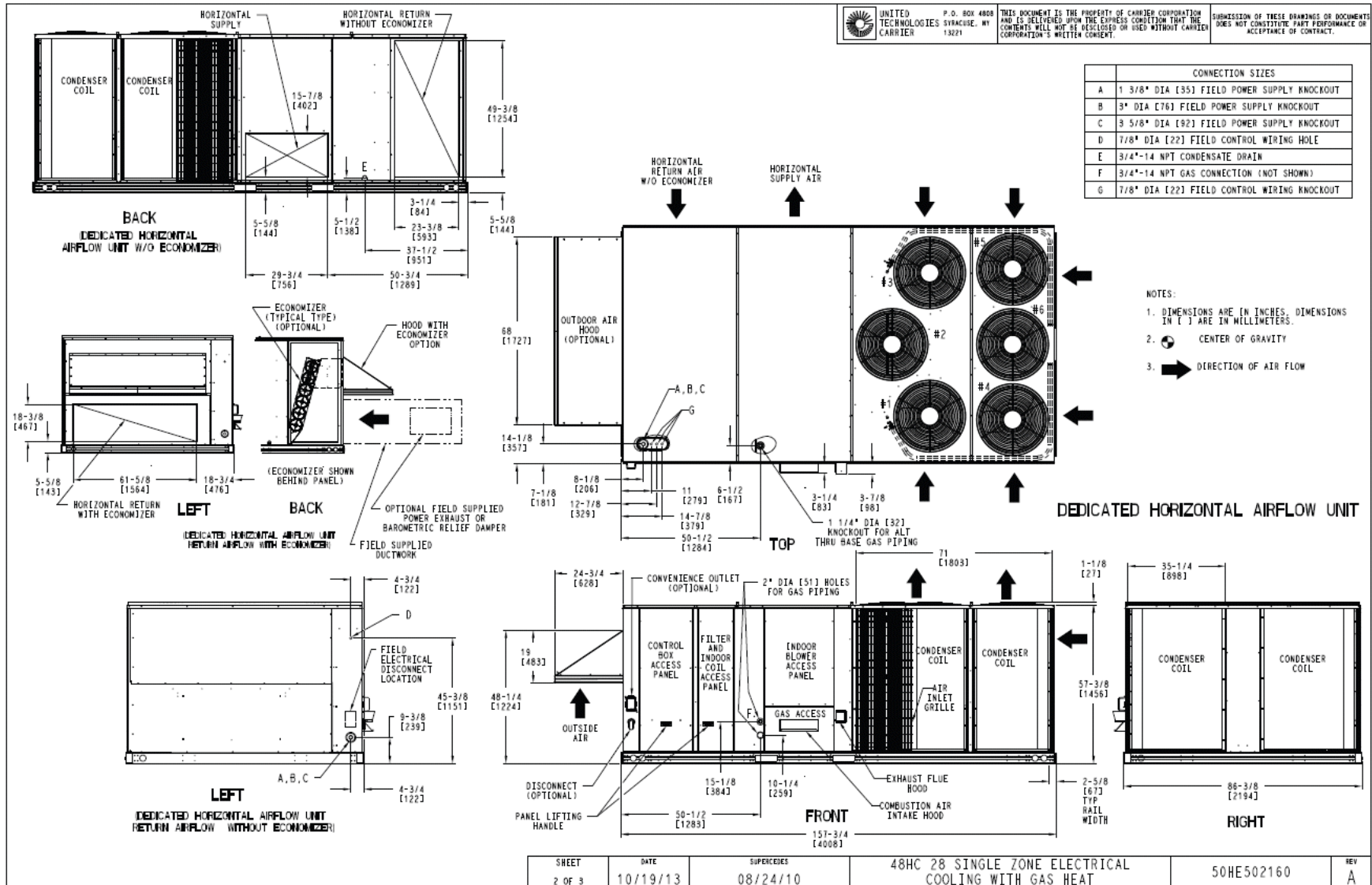

Certified Drawing for Existing 50TJ028

Project: Glen Arden Elementary
Prepared By:

12/04/2019
08:38AM

UNIT	STD UNIT WEIGHT *		CORNER WEIGHT (A)		CORNER WEIGHT (B)		CORNER WEIGHT (C)		CORNER WEIGHT (D)		C.G.					
	LBS.	KG.	LBS.	KG.	LBS.	KG.	LBS.	KG.	LBS.	KG.	X	Y	Z			
48HC28	2292	1042	577	262	559	254	583	265	602	274	44	C1118	77 1/2	(1969)	19	E483

UNITED TECHNOLOGIES P.O. BOX 4808
 CARRIER SYRACUSE, NY 13221
THIS DOCUMENT IS THE PROPERTY OF CARRIER CORPORATION AND IS DELIVERED UPON THE EXPRESS CONDITION THAT THE CONTENTS WILL NOT BE DISCLOSED OR USED WITHOUT CARRIER CORPORATION'S WRITTEN CONSENT.

* STANDARD UNIT WEIGHT IS WITH LOW GAS HEAT AND WITHOUT PACKAGING.
FOR OTHER OPTIONS AND ACCESSORIES, REFER TO THE PRODUCT DATA CATALOG.

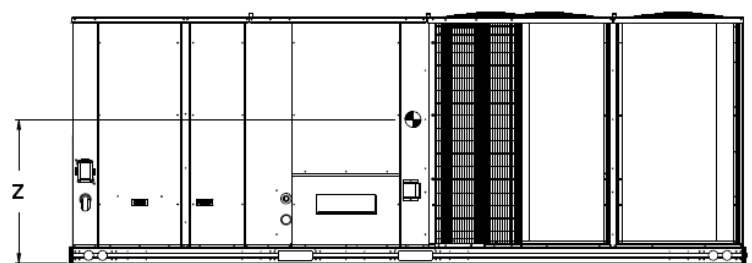
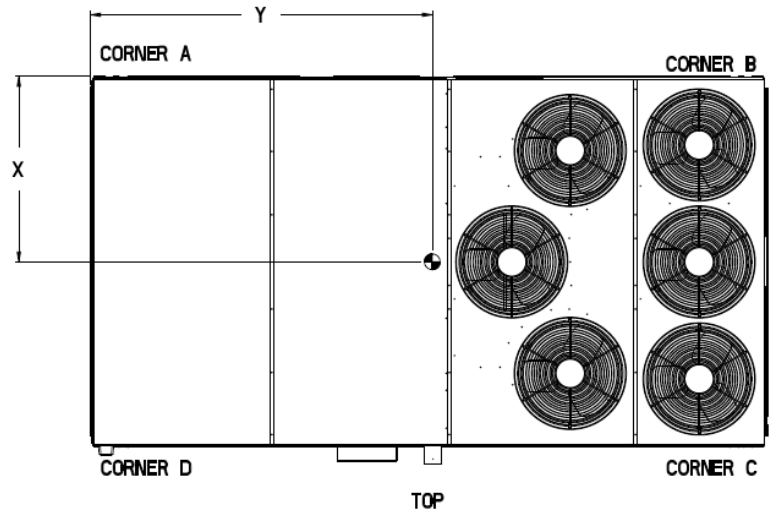

SHEET 3 OF 3	DATE 10/19/13	SUPERCESSES 08/24/10	48HC 28 SINGLE ZONE ELECTRICAL COOLING WITH GAS HEAT	50HE502160	REV A
-----------------	------------------	-------------------------	---	------------	----------

Certified Drawing for Existing 50TJ028

Project: Glen Arden Elementary
Prepared By:

12/04/2019
08:38AM

Service Clearance

C12392

LOCATION	DIMENSION	CONDITION
A	36--in (914 mm)	<ul style="list-style-type: none"> • Recommended clearance for air flow and service
B	42--in (1067 mm)	<ul style="list-style-type: none"> • Recommended clearance for air flow and service
C	18--in (457 mm)	<ul style="list-style-type: none"> • No Convenience Outlet • No Economizer • No field installed disconnect on economizer hood side (Factory--- installed disconnect installed)
	36--in (914 mm)	<ul style="list-style-type: none"> • Convenience Outlet installed • Vertical surface behind servicer is electrically non---conductive (e.g.: wood, fiberglass)
	42--in (1067 mm)	<ul style="list-style-type: none"> • Convenience Outlet installed • Vertical surface behind servicer is electrically conductive (e.g.: metal, masonry)
	96--in (2438 mm)	<ul style="list-style-type: none"> • Economizer and/or Power Exhaust installed • Check for sources of flue products with 10 feet (3 meters) of economizer fresh air intake
D	42--in (1067 mm)	<ul style="list-style-type: none"> • Recommended clearance for service

NOTE: Unit not designed to have overhead obstruction. Contact Application Engineering for guidance on any application planning overhead obstruction or vertical clearances.

Chassis 6-9

Performance Summary For Existing 50TJ028

Project: Glen Arden Elementary
Prepared By:

12/04/2019
08:38AM

Part Number:48HCRE28KCM6-2F2C0

ARI EER:.....11.20
IEER (Max Cooling at Normal Cooling Design Mode):.....12.0

Base Unit Dimensions

Unit Length:.....157.8 in
Unit Width:.....86.4 in
Unit Height:.....57.4 in

Operating Weight

Base Unit Weight:.....2292 lb
Stainless Steel, Medium Heat:.....90 lb
Two stage Cooling with Humidi-MiZer:.....120 lb
Condensate Overflow Switch and RA Smoke Detectors:.....10 lb
High Static Option with High Efficiency Motor - Vertical Models:.....16 lb
Al/Cu - Al/Cu - Louvered Hail Guard:.....150 lb
RTU Open Controller:.....2 lb
Enthalpy Economizer w/ Barometric Relief. Vertical and Horizontal Air Flow.:.....246 lb
Powered Convenience Outlet:.....35 lb
Non-Fused Disconnect:.....15 lb

Total Operating Weight:.....2976 lb

Unit

Unit Voltage-Phase-Hertz:.....460-3-60
Air Discharge:.....Vertical
Fan Drive Type:.....Belt
Actual Airflow:.....9500 CFM
Site Altitude:.....2100 ft

Cooling Performance

Condenser Entering Air DB:.....95.0 F
Evaporator Entering Air DB:.....80.0 F
Evaporator Entering Air WB:.....67.0 F
Entering Air Enthalpy:.....32.70 BTU/lb
Evaporator Leaving Air DB:.....57.8 F
Evaporator Leaving Air WB:.....56.9 F
Evaporator Leaving Air Enthalpy:.....25.16 BTU/lb
Gross Cooling Capacity:.....298.36 MBH
Gross Sensible Capacity:.....210.66 MBH
Compressor Power Input:.....20.62 kW
Coil Bypass Factor:.....0.102

Heating Performance

Heating Airflow:.....9500 CFM
Entering Air Temp:.....70.0 F
Leaving Air Temp:.....93.2 F
Gas Heating Input Capacity:.....218.2 / 272.8** MBH
Gas Heating Output Capacity:.....176.0 / 220.9** MBH
Sea Level Gas Heating Input Capacity:.....248.0 / 310.0 MBH
Temperature Rise:.....23.2 F
Thermal Efficiency (%):.....81.0
NOTE:.....** - Input/Output Capacities are at Site Altitude

Supply Fan

External Static Pressure:.....1.00 in wg
Options / Accessories Static Pressure
Humidi-MiZer Dehumidification System:.....0.11 in wg
Economizer:.....0.10 in wg
Total Application Static (ESP + Unit Opts/Acc.):.....1.20 in wg

Performance Summary For Existing 50TJ028

Project: Glen Arden Elementary
Prepared By:

12/04/2019
08:38AM

Fan RPM:..... **1157**
Fan Power:..... **6.45** BHP
NOTE:..... **Selected IFM RPM Range: 941 - 1176**

Electrical Data

Voltage Range:..... **414 - 506**
Compressor #1 RLA:..... **18.6**
Compressor #1 LRA:..... **125**
Compressor #2 RLA:..... **16**
Compressor #2 LRA:..... **140**
Indoor Fan Motor Type:..... **High Eff. High**
Indoor Fan Motor FLA:..... **14.3**
Combustion Fan Motor FLA (ea):..... **0.3**
Power Supply MCA:..... **61.2**
Power Supply MOCP (Fuse or HACR):..... **70**
Disconnect Size FLA:..... **65**
Disconnect Size LRA:..... **361**
Electrical Convenience Outlet FLA (based on unit line voltage):..... **2.2**
Outdoor Fan [Qty / FLA (ea)]:..... **6 / 0.9**
NOTE: Convenience outlet must be field connected to the line/load side of the unit disconnect per local code.

Control Panel SCCR: 5kA RMS at Rated Symmetrical Voltage

Acoustics

Sound Rating:..... **86.0** db
Sound Power Levels, db re 10E-12 Watts

	Discharge	Inlet	Outdoor
63 Hz	97.9	100.1	97.1
125 Hz	92.8	81.6	88.3
250 Hz	85.7	72.8	84.4
500 Hz	85.0	63.6	83.3
1000 Hz	79.9	58.8	80.7
2000 Hz	78.0	56.3	77.4
4000 Hz	77.2	49.6	73.4
8000 Hz	70.3	39.4	67.3
A-Weighted	87.2	75.2	85.9

Advanced Acoustics

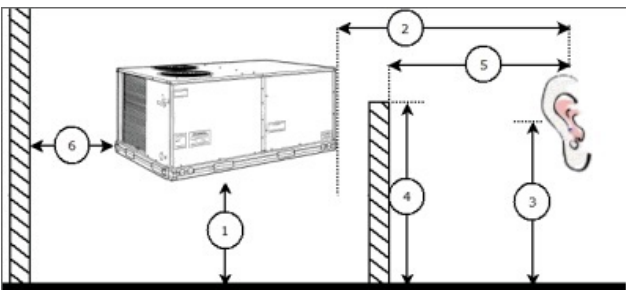

Advanced Acoustics Parameters

1. Unit height above ground:..... **30.0** ft
2. Horizontal distance from unit to receiver:..... **50.0** ft
3. Receiver height above ground:..... **5.7** ft
4. Height of obstruction:..... **0.0** ft
5. Horizontal distance from obstruction to receiver:..... **0.0** ft
6. Horizontal distance from unit to obstruction:..... **0.0** ft

Performance Summary For Existing 50TJ028

Project: Glen Arden Elementary
Prepared By:

12/04/2019
08:38AM

Detailed Acoustics Information

Octave Band Center Freq. Hz	63	125	250	500	1k	2k	4k	8k	Overall
A	97.1	88.3	84.4	83.3	80.7	77.4	73.4	67.3	98.1 Lw
B	70.9	72.2	75.8	80.1	80.7	78.6	74.4	66.2	85.9 LwA
C	64.7	55.9	52.0	50.9	48.3	45.0	41.0	34.9	65.7 Lp
D	38.5	39.8	43.4	47.7	48.3	46.2	42.0	33.8	53.5 LpA

Legend

- A Sound Power Levels at Unit's Acoustic Center, Lw
- B A-Weighted Sound Power Levels at Unit's Acoustic Center, LwA
- C Sound Pressure Levels at Specific Distance from Unit, Lp
- D A-Weighted Sound Pressure Levels at Specific Distance from Unit, LpA

Calculation methods used in this program are patterned after the ASHRAE Guide; other ASHRAE Publications and the AHRI Acoustical Standards. While a very significant effort has been made to insure the technical accuracy of this program, it is assumed that the user is knowledgeable in the art of system sound estimation and is aware of the tolerances involved in real world acoustical estimation. This program makes certain assumptions as to the dominant sound sources and sound paths which may not always be appropriate to the real system being estimated. Because of this, no assurances can be offered that this software will always generate an accurate sound prediction from user supplied input data. If in doubt about the estimation of expected sound levels in a space, an Acoustical Engineer or a person with sound prediction expertise should be consulted.

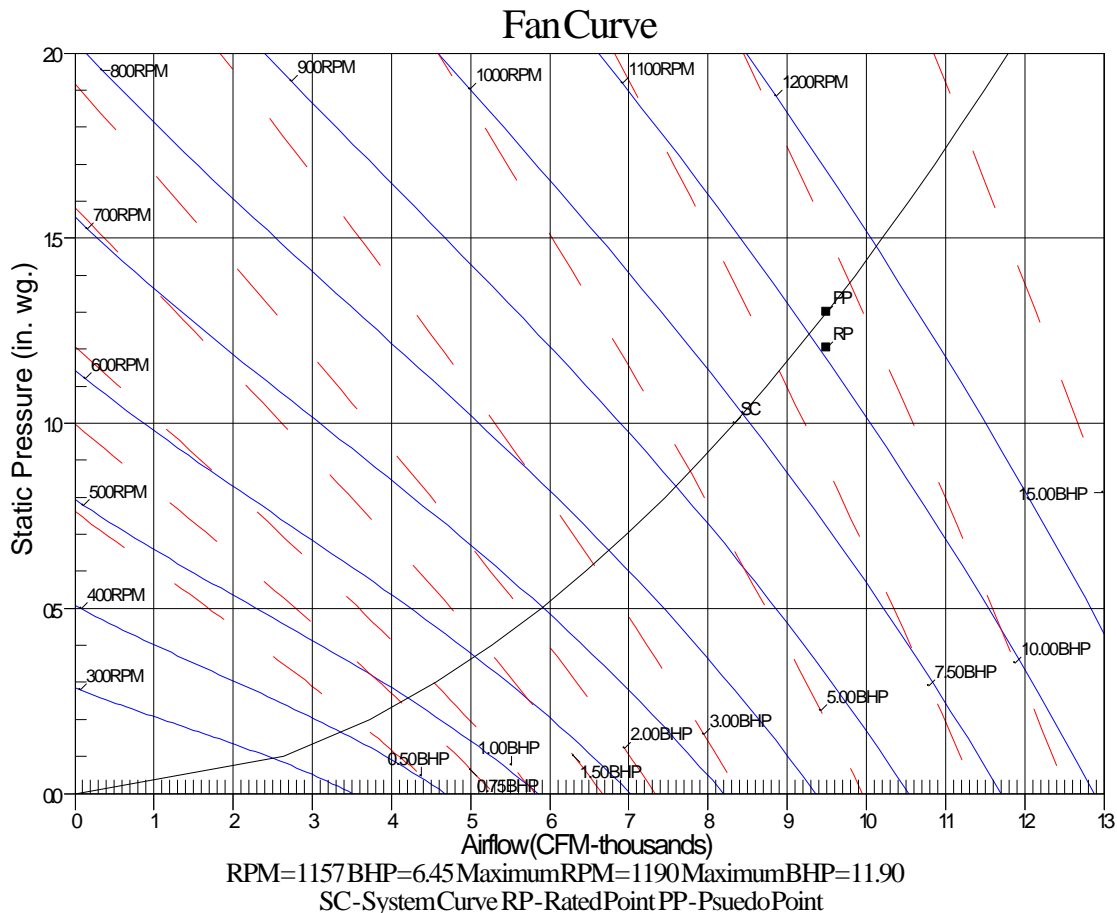

Existing 50TJQ008

Project: Glen Arden Elementary
Prepared By:

12/04/2019
08:38AM

Existing 50TJQ008

**Tag Cover Sheet
Unit Report
Certified Drawing
Performance Report**

Unit Report For Existing 50TJQ008

Project: Glen Arden Elementary
 Prepared By:

12/04/2019
 08:38AM

Unit Parameters

Unit Model:.....**48HCRE08K3M6-2F2C0**
 Unit Size:.....**08 (7.5 Tons)**
 Volts-Phase-Hertz:.....**460-3-60**
 Heating Type:.....**Gas**
 Duct Cfg:.....**Vertical Supply / Vertical Return**
 Stainless Steel, Medium Heat
 Two stage cooling models with Humidi-MiZer

Dimensions (ft. in.) & Weight (lb.) ***

Unit Length:.....**7' 4.125"**
 Unit Width:.....**4' 11.5"**
 Unit Height:.....**4' 1.375"**
 *** Total Operating Weight:.....**1205 lb**

*** Weights and Dimensions are approximate. Weight does not include unit packaging. Approximate dimensions are provided primarily for shipping purposes. For exact dimensions and weights, refer to appropriate product data catalog.

Lines and Filters

Gas Line Size:.....**1/2**
 Condensate Drain Line Size:.....**3/4**
 Return Air Filter Type:.....**Throwaway**
 Return Air Filter Quantity:.....**4**
 Return Air Filter Size:.....**20 x 20 x 2**

Unit Configuration

Condensate Overflow Switch and RA Smoke Detectors
 High Static Option - Belt Drive
 Al/Cu - Al/Cu - Louvered Hail Guards
 RTU Open Controller
 Enthalpy Economizer w/ Barometric Relief
 Powered Convenience Outlet
 Non-Fused Disconnect
 Standard Packaging
 Humidi-MiZer™ Adaptive Dehumidification System

Warranty Information

1-Year parts
 5-Year compressor parts
 15-Year heat exchanger - Stainless Steel

No optional warranties were selected.

NOTE: Please see Warranty Catalog 500-089 for explanation of policies and ordering methods.

Ordering Information

Part Number	Description	Quantity
48HCRE08K3M6-2F2C0	Rooftop Unit	1
	Base Unit	
	Condensate Overflow Switch and RA Smoke Detectors	
	High Static Option - Belt Drive	
	Al/Cu - Al/Cu - Louvered Hail Guards	
	Powered Convenience Outlet	
	RTU Open controls Low leak Enty. Econo 2 with baro relief. Meets Calf. Title 24 FDD	
	Non-Fused Disconnect	

Certified Drawing for Existing 50TJQ008

Project: Glen Arden Elementary
Prepared By:

12/04/2019
08:38AM

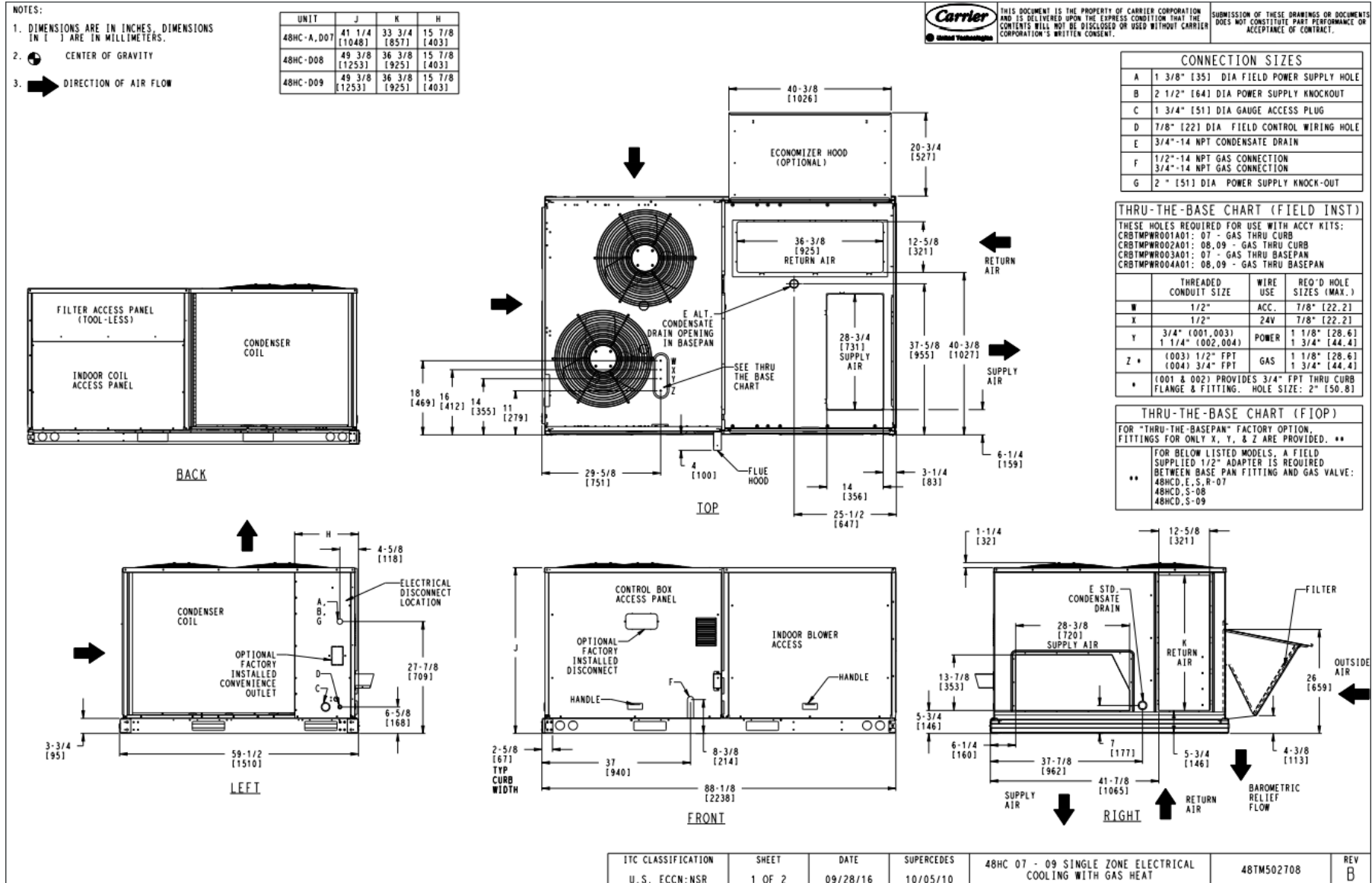

Certified Drawing for Existing 50TJQ008

Project: Glen Arden Elementary
Prepared By:

12/04/2019
08:38AM

UNIT	STD. UNIT WEIGHT *		CORNER WEIGHT (A)		CORNER WEIGHT (B)		CORNER WEIGHT (C)		CORNER WEIGHT (D)		C.G.		
	LBS.	KG.	LBS.	KG.	LBS.	KG.	LBS.	KG.	LBS.	KG.	X	Y	Z
48HC-A-D07	765	347	165.3	75	152.7	69.3	214.7	97.4	232.3	105.4	42 3/8 [1076]	34 3/4 [882.6]	19 7/8 [505]
48HC-D08	925	419.5	204.1	92.6	190.9	86.6	256.1	116.2	273.9	124.2	42 5/8 [1082]	34 1/8 [867]	22 7/8 [581]
48HC-D09	925	419.5	204.1	92.6	190.9	86.6	256.1	116.2	273.9	124.2	42 5/8 [1082]	34 1/8 [867]	22 7/8 [581]



THIS DOCUMENT IS THE PROPERTY OF CARRIER CORPORATION AND IS DELIVERED UPON THE EXPRESS CONDITION THAT THE CONTENTS WILL NOT BE DISCLOSED OR USED WITHOUT CARRIER CORPORATION'S WRITTEN CONSENT.

SUBMISSION OF THESE DRAWINGS OR DOCUMENTS DOES NOT CONSTITUTE PART PERFORMANCE OR ACCEPTANCE OF CONTRACT.

* STANDARD UNIT WEIGHT IS WITH LOW GAS HEAT AND WITHOUT PACKAGING. FOR OTHER OPTIONS AND ACCESSORIES, REFER TO THE PRODUCT DATA CATALOG.

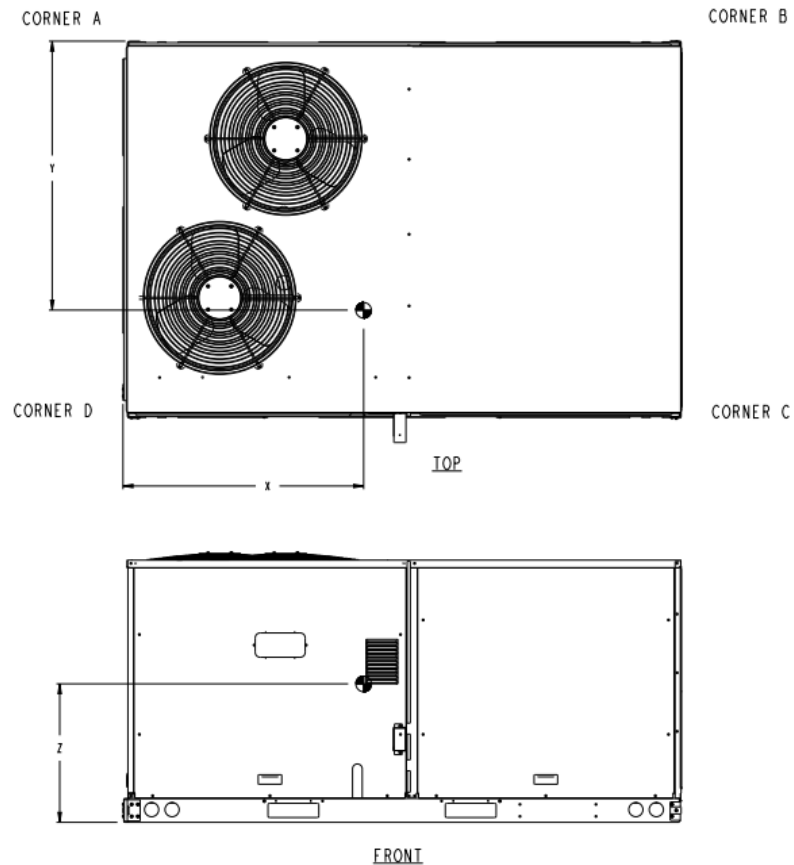

ITC CLASSIFICATION	SHEET	DATE	SUPERCEDES	48HC 07 - 09 SINGLE ZONE ELECTRICAL COOLING WITH GAS HEAT	48TM502708	REV
U.S. ECCN: NSR	2 OF 2	09/28/16	10/05/10			B

Certified Drawing for Existing 50TJQ008

Project: Glen Arden Elementary
Prepared By:

12/04/2019
08:38AM

Service Clearance

C11247

LOCATION	DIMENSION	CONDITION
A	48-in (1219 mm)	• Unit disconnect is mounted on panel
	36-in (914 mm)	• If dimension-B is 12-in (305 mm)
	18-in (457 mm)	• No disconnect, convenience outlet option
	12-in (305 mm)	• Recommended service clearance (use electric screwdriver)
	36-in (914 mm)	• Minimum clearance (use manual ratchet screwdriver)
B	36-in (914 mm)	• Unit has economizer
	12-in (305 mm)	• If dimension-A is 36-in (914 mm)
	Special	• Check for sources of flue products within 10-ft of unit fresh air intake hood
C	36-in (914 mm)	• Side condensate drain is used
	18-in (457 mm)	• Minimum clearance
D	48-in (1219 mm)	• No flue discharge accessory installed, surface is combustible material
	42-in (1067 mm)	• Surface behind servicer is grounded (e.g., metal, masonry wall, another unit)
	36-in (914 mm)	• Surface behind servicer is electrically non-conductive (e.g., wood, fiberglass)
	Special	• Check for adjacent units or building fresh air intakes within 10-ft of this unit's flue outlet

NOTE: Unit not designed to have overhead obstruction. Contact Application Engineering for guidance on any application planning overhead obstruction or vertical clearances.

Chassis 3-4a

Performance Summary For Existing 50TJQ008

Project: Glen Arden Elementary
 Prepared By:

12/04/2019
 08:38AM

Part Number:48HCRE08K3M6-2F2C0

ARI EER:.....**12.00**
 IEER (Max Cooling at Normal Cooling Design Mode):.....**13.0**

Base Unit Dimensions

Unit Length:.....**88.1** in
 Unit Width:.....**59.5** in
 Unit Height:.....**49.4** in

Operating Weight

Base Unit Weight:.....**925** lb
 Stainless Steel, Medium Heat:.....**15** lb
 Two stage cooling models with Humidi-MiZer:.....**80** lb
 Condensate Overflow Switch and RA Smoke Detectors:.....**10** lb
 High Static Option - Belt Drive:.....**15** lb
 Al/Cu - Al/Cu - Louvered Hail Guards:.....**34** lb
 RTU Open Controller:.....**2** lb
 Enthalpy Economizer w/ Barometric Relief:.....**74** lb
 Powered Convenience Outlet:.....**35** lb
 Non-Fused Disconnect:.....**15** lb

 Total Operating Weight:.....**1205** lb

Unit

Unit Voltage-Phase-Hertz:.....**460-3-60**
 Air Discharge:.....**Vertical**
 Fan Drive Type:.....**Belt**
 Actual Airflow:.....**3000** CFM
 Site Altitude:.....**2100** ft

Cooling Performance

Condenser Entering Air DB:.....**95.0** F
 Evaporator Entering Air DB:.....**80.0** F
 Evaporator Entering Air WB:.....**67.0** F
 Entering Air Enthalpy:.....**32.70** BTU/lb
 Evaporator Leaving Air DB:.....**58.4** F
 Evaporator Leaving Air WB:.....**57.3** F
 Evaporator Leaving Air Enthalpy:.....**25.46** BTU/lb
 Gross Cooling Capacity:.....**90.55** MBH
 Gross Sensible Capacity:.....**64.74** MBH
 Compressor Power Input:.....**5.84** kW
 Coil Bypass Factor:.....**0.050**

Heating Performance

Heating Airflow:.....**3000** CFM
 Entering Air Temp:.....**70.0** F
 Leaving Air Temp:.....**113.4** F
 Gas Heating Input Capacity:.....**105.6 / 158.4**** MBH
 Gas Heating Output Capacity:.....**86.2 / 130.2**** MBH
 Sea Level Gas Heating Input Capacity:.....**120.0 / 180.0** MBH
 Temperature Rise:.....**43.4** F
 Thermal Efficiency (%):.....**82.0**

NOTE:.....**** - Input/Output Capacities are at Site Altitude**

Supply Fan

External Static Pressure:.....**1.00** in wg
 Options / Accessories Static Pressure
 Humidi-MiZer Dehumidification System:.....**0.18** in wg
 Economizer:.....**0.11** in wg
 Total Application Static (ESP + Unit Opts/Acc.):.....**1.29** in wg

Performance Summary For Existing 50TJQ008

Project: Glen Arden Elementary
 Prepared By:

12/04/2019
 08:38AM

Fan RPM:.....**992**
 Fan Power:.....**1.85** BHP
 NOTE:.....**Selected IFM RPM Range: 838 - 1084**

Electrical Data

Voltage Range:.....**414 - 506**
 Compressor #1 RLA:.....**6.1**
 Compressor #1 LRA:.....**41**
 Compressor #2 RLA:.....**6.1**
 Compressor #2 LRA:.....**41**
 Indoor Fan Motor Type:.....**HIGH**
 Indoor Fan Motor FLA:.....**5.3**
 Combustion Fan Motor FLA (ea):.....**0.25**
 Power Supply MCA:.....**23**
 Power Supply MOCP (Fuse or HACR):.....**25**
 Disconnect Size FLA:.....**24**
 Disconnect Size LRA:.....**131**
 Electrical Convenience Outlet FLA (based on unit line voltage):.....**2.2**
 Outdoor Fan [Qty / FLA (ea)]:.....**2 / 0.8**
 NOTE: Convenience outlet must be field connected to the line/load side of the unit disconnect per local code.

Control Panel SCCR: 5kA RMS at Rated Symmetrical Voltage

Acoustics

Sound Power Levels, db re 10E-12 Watts

	Discharge	Inlet	Outdoor
63 Hz	97.8	95.1	90.6
125 Hz	91.9	86.3	84.3
250 Hz	77.5	72.2	80.2
500 Hz	70.7	66.0	79.3
1000 Hz	67.0	63.5	77.1
2000 Hz	65.6	58.8	72.2
4000 Hz	68.0	58.7	67.4
8000 Hz	70.0	57.7	63.7
A-Weighted	79.6	74.3	82.0

Advanced Acoustics

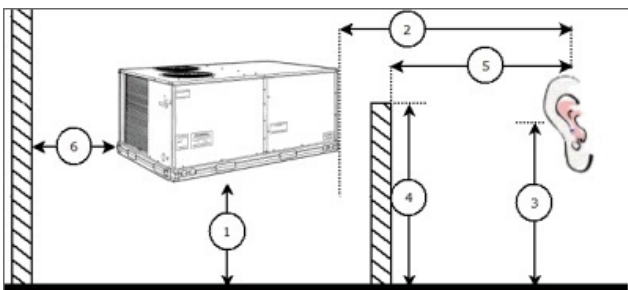

Advanced Accoustics Parameters

1. Unit height above ground:.....**30.0** ft
 2. Horizontal distance from unit to receiver:.....**50.0** ft
 3. Receiver height above ground:.....**5.7** ft
 4. Height of obstruction:.....**0.0** ft
 5. Horizontal distance from obstruction to receiver:.....**0.0** ft
 6. Horizontal distance from unit to obstruction:.....**0.0** ft

Performance Summary For Existing 50TJQ008

Project: Glen Arden Elementary
Prepared By:

12/04/2019
08:38AM

Detailed Acoustics Information

Octave Band Center Freq. Hz	63	125	250	500	1k	2k	4k	8k	Overall
A	90.6	84.3	80.2	79.3	77.1	72.2	67.4	63.7	92.3 Lw
B	64.4	68.2	71.6	76.1	77.1	73.4	68.4	62.6	81.7 LwA
C	58.2	51.9	47.8	46.9	44.7	39.8	35.0	31.3	59.9 Lp
D	32.0	35.8	39.2	43.7	44.7	41.0	36.0	30.2	49.3 LpA

Legend

- A Sound Power Levels at Unit's Acoustic Center, Lw
- B A-Weighted Sound Power Levels at Unit's Acoustic Center, LwA
- C Sound Pressure Levels at Specific Distance from Unit, Lp
- D A-Weighted Sound Pressure Levels at Specific Distance from Unit, LpA

Calculation methods used in this program are patterned after the ASHRAE Guide; other ASHRAE Publications and the AHRI Acoustical Standards. While a very significant effort has been made to insure the technical accuracy of this program, it is assumed that the user is knowledgeable in the art of system sound estimation and is aware of the tolerances involved in real world acoustical estimation. This program makes certain assumptions as to the dominant sound sources and sound paths which may not always be appropriate to the real system being estimated. Because of this, no assurances can be offered that this software will always generate an accurate sound prediction from user supplied input data. If in doubt about the estimation of expected sound levels in a space, an Acoustical Engineer or a person with sound prediction expertise should be consulted.

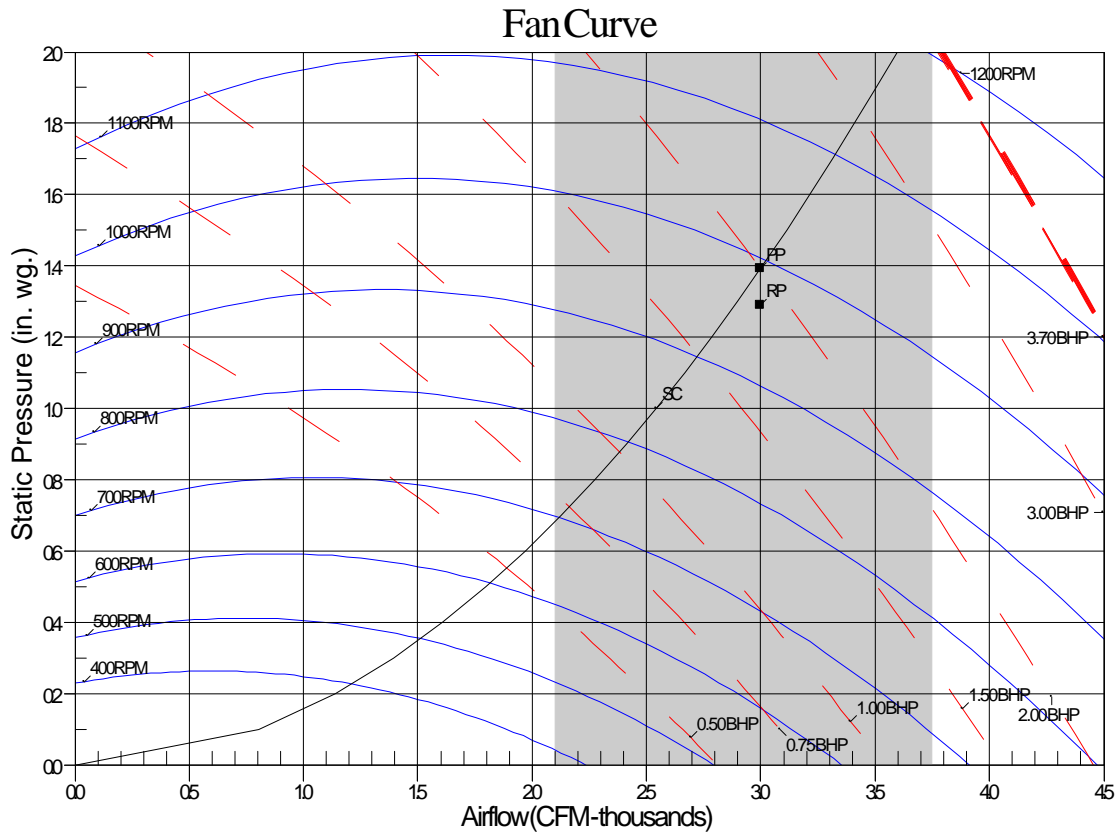

RPM=992 BHP=1.85 Maximum RPM=1400 Maximum BHP=3.70
 Note: Please contact application engineering for selections outside the shaded region.
 SC-System Curve RP-Rated Point PP-Pseudo Point