

Modesto City Schools *English Learner Master Plan*

Updated January 2020



A Message from the Superintendent



Board of Education

Cindy Marks
President

Charlene West, Ph.D.
Vice President

Chad Brown
Board Member

John Ervin III
Board Member

Adolfo Lopez
Board Member

Amy Elliott Neumann
Board Member

John Walker
Board Member



The goal of Modesto City Schools is to prepare every student for the first day after graduation, whatever path they have chosen. Whether their choice is the workforce, military, junior college or university, our job is to ensure they are college and career ready.

Modesto City Schools serves approximately 30,000 students and 25% of those students are English Learners. Our District has the privilege and responsibility of ensuring that all multilingual students become proficient in English and master the academic content required of every student in California.

The English Learners Master Plan is our guide that will ensure our English Learners reach the highest levels of academic achievement and full proficiency in English. Modesto City Schools strives to achieve these goals by implementing the highest quality, evidence-based programs and services for these students.

I offer my sincere thanks to everyone who participated in the process and development of our English Learner Master Plan.

Sara Noguchi, Ed.D
Superintendent



Table of Contents

| | |
|---|---------------------------|
| <p>Section 1: Introduction</p> <ul style="list-style-type: none"> • Vision, Mission, Values • Federal Funding <ul style="list-style-type: none"> ◦ <i>Use of funds</i> • Special Thank You | <p>Pages 5-8</p> |
| <p>Section 2: Identification and Placement</p> <ul style="list-style-type: none"> • English Learner Team • Initial Identification and Placement <ul style="list-style-type: none"> ◦ <i>The Enrollment Process</i> ◦ <i>Parent Notification of Students with a TBD Status</i> ◦ <i>Initial ELPAC Assessment</i> ◦ <i>Parent Notification of Initial ELPAC Results</i> ◦ <i>Classification Review Process</i> ◦ <i>The Pathway to EO, EL, IFEP, and RFEP</i> • ELPAC <ul style="list-style-type: none"> ◦ <i>Initial ELPAC</i> ◦ <i>Summative ELPAC</i> ◦ <i>ELPAC Supports for Students who Receive Special Education Services</i> | <p>Pages 9-14</p> |
| <p>Section 3: K-12 Instructional Programs and Services</p> <ul style="list-style-type: none"> • Instructional Programs and Services <ul style="list-style-type: none"> ◦ <i>Structured English Immersion</i> ◦ <i>Newcomer Program (Language Institute)</i> ◦ <i>Dual Language Academy</i> • Designated and Integrated ELD <ul style="list-style-type: none"> ◦ <i>Designated and Integrated</i> ◦ <i>Designated ELD</i> ◦ <i>Integrated ELD</i> ◦ <i>Program Opt-Out</i> • Elementary English Language Development <ul style="list-style-type: none"> ◦ <i>Elementary Program Structure</i> ◦ <i>Elementary Program Placement</i> • Secondary English Language Development <ul style="list-style-type: none"> ◦ <i>Secondary Program Structure</i> ◦ <i>Secondary Program Placement</i> • Supporting English Learners <ul style="list-style-type: none"> ◦ <i>At-Risk LTELs and LTELs</i> ◦ <i>Advanced Courses & Gifted and Talented Programs</i> ◦ <i>IEPs or 504 Plans</i> | <p>Pages 15-23</p> |

Table of Contents

- Accountability
 - *Elementary Program Monitoring*
 - *Secondary Program Monitoring*

Section 4: Instructional Practices & Professional Development **Pages 24-30**

- Instructional Practices
 - *2012 California English Language Development Standards*
 - *ELD Standards: Parts I, II, III*
 - *ELD Proficiency Levels*
 - *High Impact Instructional Strategies for Designated ELD*
 - *What is SDAIE?*
- Professional Development

Section 5: Reclassification and State Seal of Biliteracy **Pages 31-34**

- Reclassification
 - *Reclassification Criteria*
 - *Reclassification Process*
 - *Reclassification Monitoring*
 - *Reclassification for Students who are Eligible for Alternative Reclassification*
- State Seal of Biliteracy
 - *State Seal of Biliteracy Requirements*
 - *Eligibility Criteria for a Student Whose Primary Language is English*
 - *Eligibility Criteria for a Student Whose Primary Language is not English*
 - *Benefits of Earning the State Seal of Biliteracy*

Section 6: Parent Advisory Committees **Pages 35-37**

- English Learner Advisory Committee (ELAC)
 - *Requirements*
 - *Elections*
 - *Guidelines*
- District English Learner Advisory Committee (DELAC)
 - *Requirements*
 - *Meetings*

Appendices **Pages 38-40**

- Program Options for Language Acquisition-Grades K-6
- Program Options for Language Acquisition-Grades 7-12
- English Learner Reclassification Criteria Chart

Section 1

Introduction

Modesto City Schools (MCS) is in the city of Modesto, which was founded in 1870- connecting Sacramento and Los Angeles. Modesto is the largest city of Stanislaus county; MCS is located in the Central Valley, which is known for its agricultural staples.

MCS comprises 22 elementary schools, 4 Junior High Schools, 7 High Schools and a Comprehensive Alternative High School. MCS currently serves over 30,000 students TK through 12th Grade. Approximately 25% of Modesto City Schools students are English Learners (ELs).

Vision Mission and Values

Vision: Every student graduates with the skills, knowledge, and character traits essential to thrive and contribute to society.

Mission: We provide rigorous, relevant, and diverse educational programs that engage and motivate all students to reach their individual potential by:

- Providing a safe and welcoming learning and working environment.
- Ensuring all students have access to the highest quality instruction and learning conditions, and graduate college and career ready.
- Creating a culture of high expectations for all students and employees.
- Supporting our staff in making data-driven decisions that are in the best interest of students.
- Encouraging trust through open, honest and ongoing communication across all members of our school community.

Values: We believe:

- Every student deserves our best, every day and in every situation.
- All students will know we believe in them, and that they are the focus of our work.
- Every interaction with students matters and is an opportunity to teach and show we care.
- Positive, collaborative school-community relationships are built on trust and respect.
- Educating the whole child is maximized by creating meaningful partnerships with communities, families, parents/guardians, and educators.
- Our students and employees will strive to model our nine character traits.
- Continuous learning and sharing new ideas, best practices, and offering support to one another helps us improve.

Section 1

Federal Funding

Modesto City Schools receives state funding through the **Local Control Funding Formula (LCFF)** as well as federal funding in categorical funds to fund its English learner services.

Title III funds are categorical funds provided by the government to support programs that help English learners develop full proficiency in English and reach high academic standards in content areas. The District may use Title III funds to:

- support the development of innovative programs that are in addition to the core ELD curriculum
- purchase supplementary instructional and assessment materials
- provide support for deep and sustained professional development for teachers that focuses on the improvement of instruction and assessment for English learners
- increase parent involvement
- provide direct EL student support above and beyond that which is provided through general funds and core program
- improve instruction and assessment for English learners

Sites may use funding to supplement, not supplant, general funds or other categorical resources at the school. For example:

- Title III Immigrant Education funds provide supplemental support (i.e. parent and student liaison, translation services) for eligible students.
- A maximum of two percent of Title III funds may be allocated to administrative costs. The District will take the County Office of Education (COE)-established indirect cost rate each year.
- Categorical carry-over from any of the above described funding sources will be limited to five percent.
- All expenditures of categorical funds by the school site will be described within the school's Single Plan for Student Achievement (SPSA). Every School Site Council (SSC) will solicit program and budget recommendations from the English Learner Advisory Committee (ELAC). The SSC will approve and recommend the school's plan to the Board of Education.
- Expenditures of categorical funds will be described as required by the program from which the funds are received.
- The District personnel responsible for the funds (i.e. Director overseeing EL programs, Director of Finance, etc), as well as DELAC, will provide further oversight of the expenditure of these funds.

Section 1

Other categorical funds that may be used to provide supplemental services and programs for English learners include:

- Federal Title I, Part A funds, which may be utilized to help improve instruction in high poverty schools to ensure that all students meet state academic standards.

For any equipment with an acquisition cost of more than \$500, MCS will tag the equipment and log these acquisitions into a District database.

Use of Funds

The District uses Title III Immigrant funds, along with other funds, to support eligible immigrant students ages 3 to 21 with additional support in the classroom. The priority has been to the newly arrived immigrants. All immigrant students in Modesto Elementary District are currently ELs.

Upon identification of a student as an immigrant, MCS assesses the student to determine academic, social, and emotional needs as well as the needs of the parents, guardians and families of the immigrant student.

Placement of immigrant students into appropriate courses including supplemental instructional settings is determined based on assessments.

As needed, the following instructional opportunities are provided to immigrant students and families:

- Parent and family outreach such as home visits.
- Meetings with counselors to support immigrant students in areas of academic or career counseling.
- Training activities designed to assist parents and families of immigrant students such as ELPAC bootcamp and technology trainings on PowerSchool.
- Intervention support staff provide and coordinate tutorials, mentoring, and academic or career counseling for immigrant children and youth.
- Activities, coordinated with community-based organizations such as Center for Human Services, Modesto Junior College through Migrant Ed., and World Relief which has expertise in working with immigrants, are offered to assist parents and families of immigrant children and youth by offering comprehensive community services.

Section 1

- MCS instructional services that are designed to assist immigrant children and youth to achieve in elementary schools in the United States such as programs of introduction to the educational system and civics education; and is provided during their ELD time as currently all immigrant students in MCS are ELs. Should there be an identified immigrant that is not an EL, the District would ensure that these instructional services would be provided via another avenue.
- Supplemental instruction during winter and summer break is provided to support programs of introduction to the educational system and civics education.
- To enhance the instructional opportunities to eligible immigrant students, paraprofessionals are provided for additional support.

The District is taking measures to ensure the recruitment of and support for personnel, including teachers and paraprofessionals, and will provide training specifically to provide services to immigrant children and youth.

The District has identified, developed, and/or acquired curricular materials, educational software, and technologies to support immigrant students.

Special Thank You

We would like to acknowledge and give special thanks to the committee members for their time and dedication. Thank you to the dedicated teachers, administrators, and parents who have worked to ensure English Learners in Modesto City Schools are provided with research-based instructional programs to become proficient in English and master grade-level standards.

Jennifer Aguirre
 Graciela Benavidez
 Joanna Carrillo
 Rouy Chhoeung
 Heather Contreras
 Ana Garibay
 Francisco Guerrero
 Janeth Gutierrez

Adriana Huerta
 Lori Jonas
 Monica Lombardo
 Otilia Martiniuc
 Ana Mora
 Maricela Mota
 Laura Nava
 Rosalba Ochoa

Lauren Odell
 Lorena Ortega
 David Sanchez
 Michael Shroyer
 Victor Soria
 Zamanda Vall

Section 2

Identification and Placement

English Learner Team

The Director II of English Learner Services oversees the TK-12 English Learner programs supporting current English Learners, reclassified students, and a State Seal of Biliteracy pathway. The Director II of English Learner Services supports the EL program in the following ways:

- Provides placement recommendations
- Supports ELD teachers
- Seal of Biliteracy process
- Dual Language Academy (DLA) and Language Institute (LI)



Under the Director II of English Learner Services, the Administrator of Special Projects and the Assessment Center Staff support the EL program in the following ways:

- Ensure administration of EL assessment testing is completed, such as Initial and Summative ELPAC
- Initiate the reclassification process
- Monitor reclassified students
- Update EL information in the student information system



In addition, every site has teachers who teach integrated ELD and/or designated ELD to ELs K-12. At the elementary level, the classroom teachers are also the ELD teachers. At the secondary level, there are specific teachers who teach designated English Language Development (ELD), also known as Academic Language Development (ALD). Human Resources (HR) verifies that all teachers who teach English learners are appropriately credentialed. Sites are responsible for selecting highly-qualified teachers to deliver ELD instruction. All teachers use strategies to support their ELs throughout the day in integrated ELD. All district coaches support integrated ELD, while some district coaches specifically support designated ELD. All educators are responsible for the academic language development of our English learners.

Section 2

Initial Identification and Placement



The Enrollment Process

Each student enrolled in Modesto City Schools must be formally identified as either a native English Only (EO) speaker, an English Learner (EL), an Initial Fluent English Proficient (I-FEP), or as a Reclassified Fluent English Proficient (R-FEP) student.

The following procedures are used to determine the official English proficiency of each student:

- The parent/guardian completes a **Home Language Survey (HLS)** section on the Enrollment Card, as required by state and federal law, when registering his/her students.
- The HLS consists of the following four questions:
 - Language first spoken by child?
 - Language most spoken by child at home?
 - Language most spoken to child at home?
 - Language most spoken by adults at home?
- The questions are used to determine a student's home language status as follows:
 - English Only (EO): If the answers to the four questions on the HLS are "English", the child is classified as English Only.
 - To Be Determined (TBD): If the answers to *any* of the first *three* questions on the HLS indicate a language other than English, or a combination of English and another language, the student is assessed using a state mandated assessment tool.

Parent Notification of Students with a TBD Status

When a student has a *TBD* status, parents receive a letter notifying them that on the Home Language Survey they indicated that their child's primary language is something other than English and that their child will be administered the Initial ELPAC assessment. If parents believe they made a mistake on the Home Language Survey, they need to contact the Administrator of Special Projects at (209) 574-1590 as soon as possible.

Section 2

Initial ELPAC Assessment

The English Language Proficiency Assessments for California (ELPAC) is the current state mandated assessment tool used to determine the students' English proficiency status. Assessment Center personnel and/or certified test administrators will administer the test within 30 calendar days of the first day of school, or within 30 days of enrollment (5 CCR § 11308(a)). The results of the ELPAC will indicate the student's English language proficiency level as follows:

- Initially Fluent English Proficient (IFEP): Students who are IFEP will not receive EL services.
- English Learner (EL): Students who are ELs (either Novice or Intermediate) will receive EL services through *integrated* and *designated* English Language Development instruction through the District's Structured English Immersion (SEI) program.

Parent Notification of Initial ELPAC Results

After Assessment Center personnel has administered and scored the Initial ELPAC, parents of English learners will be notified via letter of their child's score and program placement. Per Title III guidelines, Assessment Center personnel will mail the letter within 30 days of a student's initial enrollment (20 U.S.C § 7012(e)(1)). Parents or guardians who would like to further discuss the results of the Initial ELPAC are encouraged to contact the Assessment Center.

Classification Review Process

At any point before the *first* administration of the Summative ELPAC, but after the administration of the Initial ELPAC, a parent or guardian has the right to request an amendment to their student's EL classification. The District will honor the request and review the student's classification based on multiple criteria, including:

- the results of an objective language proficiency assessment tool (including, but not limited to, the Initial ELPAC),
- evaluation of the student's academic progress, and
- parent and teacher consultation.



Section 2

Following the review, the District will notify in writing the parent/guardian of their findings and decision to either maintain or change the student’s original EL classification. However, once the student has taken the Summative ELPAC, the parent/guardian can no longer amend the language classification, and the student will maintain their EL classification until they meet the criteria for reclassification. The classification review process can only occur once during the child’s enrollment in the California public school system.

The Pathway to EO, EL, IFEP, and RFEP

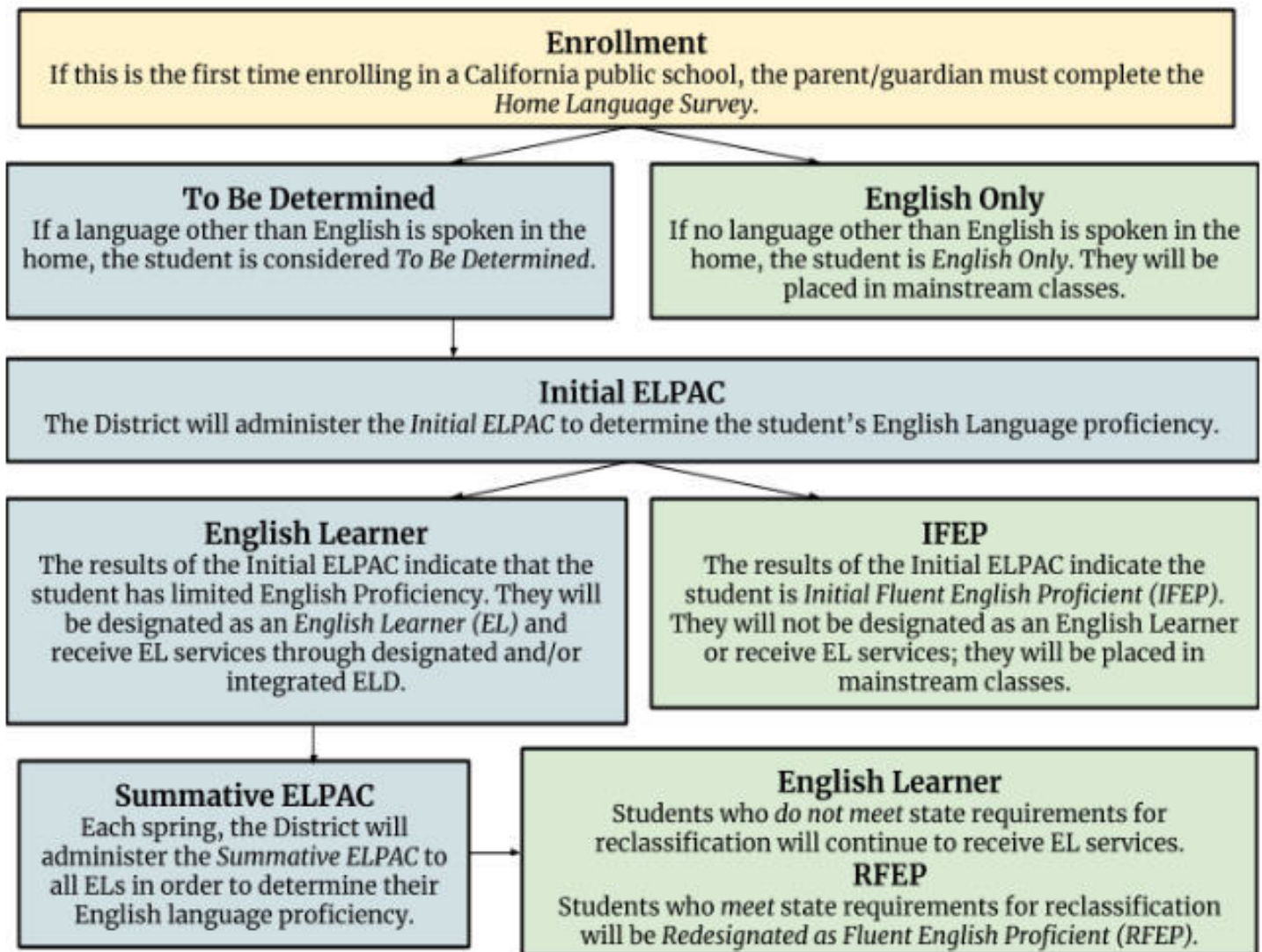

Section 2

ELPAC

As of the 2017-2018 school year, the English Language Proficiency Assessment for California, or ELPAC, is the state-mandated assessment tool to determine a student's English language proficiency. The Initial ELPAC is administered to each student only once upon their initial enrollment into a California public school. The Summative ELPAC is administered annually in the spring to determine an EL's language proficiency and provide placement data for the following school year (5 CCR § 11306).

Initial ELPAC

California public school districts use the Initial ELPAC to determine a student's English language proficiency. The Initial ELPAC is administered within 30 days of a child's enrollment by certified District test administrators.

A student will take the Initial ELPAC if:

- The student has never been previously enrolled in a California public school district.
- The student has not previously been classified as an EL.
- There is reasonable doubt concerning the student's English language proficiency.

The results of the Initial ELPAC determine a student's placement in the District language acquisition program. Students who score IFEP are not classified as ELs and do not receive EL services. Students who score Novice or Intermediate are classified as English learners and will receive designated and integrated ELD instruction through the District's SEI program.

In accordance with the requirements for Title I and Title III funding, parents/guardians of ELs are notified of their student's Initial ELPAC score within 30 calendar days by the Administrator of Special Projects. The results will include:

- reasons for the student's identification as an EL based on the ELPAC results
- need for placement in an English language development program



Section 2

Summative ELPAC

The Summative ELPAC assessment is given each spring to all ELs in grades kindergarten through twelve who have not been reclassified (EC 313(d)(2)). This assessment measures the yearly progress of ELs in acquiring the skills of listening, speaking, reading, and writing in English. Results of the Summative ELPAC assessment are used as one measure for reclassification. Within 30 days after the District receives Summative ELPAC results, or within two weeks of the start of the next school year if results are received after the last day of instruction, the Administrator of Special Projects will notify parents of the results of the assessment. These notifications will include:

- individual student result reports, which show the overall performance level attained by the students in listening, speaking, reading and writing
- the reasons for the student's continued identification as an EL based on the ELPAC results
- the continued need for placement in the District language acquisition program

Districtwide results for the Summative ELPAC can be found on the California Dashboard (caschooldashboard.org).

ELPAC Supports for Students who Receive Special Education Services

Under the guidelines of a student's Individualized Education Program (IEP), supports and accommodations can be made for both the Initial and Summative ELPAC. For more information on supports and accommodations, please contact the case manager in charge of the student's IEP. In addition, under the guidelines of a student's IEP, the alternative ELPAC assessment or an alternative assessment may be administered. For more information on the alternative ELPAC assessment, please contact the case manager in charge of the student's IEP.

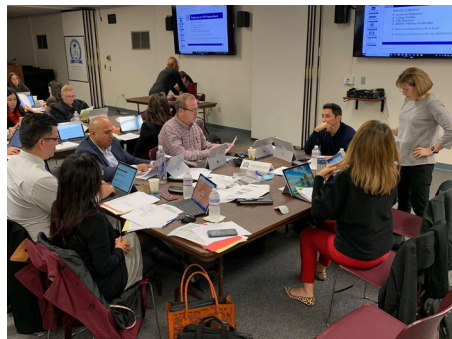

Section 3

K-12 Instructional Programs and Services

Instructional Programs and Services

Each English Learner (EL) identified in Modesto City Schools will receive special instructional assistance to help develop English proficiency and to promote academic success. The common goal for all English Learners is to be reclassified proficient in English as measured by the English Language Proficiency Assessments for California (ELPAC) and other criteria. *(See Section 5 - Reclassification for further details)*

In order to accomplish this goal the District has the following instructional programs:

- A. Structured English Immersion (SEI)
- B. Newcomer Program (Language Institute)
- C. Dual Language Academy (DLA)

Services and Support Offered:

- English Learner Services
- English Language and Literacy Programs for English Learners
- Textbook Adoption for Spanish Language
- Newcomer Services and Support
- State and Federal Programs: Title I, Title III, Title V
- Staff Development
- EL Instructional Assistant Support and Paraprofessional Development
- Private Schools
- Language Census
- Language Proficiency Assessments
- Federal Program Monitoring (FPM)
- District English Language Advisory Committee (DELAC)

Structured English Immersion (SEI)

The SEI program is the language acquisition program offered in MCS. English learners will receive English language development through the SEI model. The SEI program is primarily taught in English, and blends both designated and integrated English Language Development (ELD) instruction (5CCR § 11309).

Newcomer Program (Language Institute)

The Newcomer Program is a parent choice program for English Learners with less than 12

Section 3

months of U.S. schooling; the Program is located at Tuolumne Elementary, Roosevelt Junior High and Davis High School. The programs goal is to ensure English aquisition as rapidly and effectively as possible while also providing core content classes. For more information parents can call (209)574-1590.

Dual Language Academy

The Dual Language Academy (DLA) is for both English Learners and fluent English students. The DLA goal is bilingualism and biliteracy in both English and Spanish. The Dual Language Academy (DLA) is a districtwide program which is hosted at Bret Harte Elementary School and Hanshaw Junior High School. Both English and Spanish instruction are used 50% each day. Entry into the DLA in grades K-1 is open and based on space availability; entry in grades 2-8 must meet entry criteria. (*See DLA Handbook for specific details*)

Parents or guardians of students enrolled in the school may choose a language acquisition program that best suits their child. To do so, parents need to contact the Assessment Center at (209)574-1590. In order to keep an accurate record of the input, the Administrator of Special Projects will ask parents the following:

- School site
- Date of request
- Parent/Guardian name
- Student name
- Student grade level
- General description of parent request



Designated and Integrated ELD

Designated and Integrated

The ELD Framework recommends an ELD program that incorporates both designated and integrated ELD instruction to support English learners at all levels of English language proficiency. Because the needs of elementary and secondary English learners vary greatly, MCS has designed an elementary ELD program and a secondary ELD program. According to the ELD standards, "ELs entering California schools in kindergarten, for example, will benefit from participating in the same instructional activities in literacy as their non-EL peers, along with additional differentiated support based on student need. EL students who enter secondary grades, depending upon the level of previous schooling they have received, may need additional support mastering

Section 3

certain linguistic and cognitive skills in order to fully engage in intellectually challenging tasks" (CA ELD Standards, 9). Therefore, designated ELD program structure and instruction differ between the elementary and secondary levels.

Designated ELD

Per state guidelines, all English learners must receive daily, designated ELD instruction. In designated ELD, "the classroom teacher uses the CA ELD standards as the focal standards in ways that build into and from content instruction in order to develop critical language ELs need for content learning in English" (CA ELD Standards, 9). Designated ELD is a daily, protected instructional time in which the classroom teacher intentionally aligns their instruction to the CA ELD standards in order to build students' development and understanding of the English language. Students may receive designated ELD in one of two ways:

1. During a separate class period or instructional block of time. At the elementary level, designated ELD is provided during specific protected time. At the secondary level, designated ELD is provided in a distinct course titled "Academic Language Development (ALD)". This structure is recommended for students who are at the emerging to bridging language proficiency levels.
2. In a small group within the context of an English Language Arts (ELA) class. This structure is recommended for students who are at the emerging to bridging language proficiency levels. In designated ELD, students are taught by a highly-qualified classroom teacher who has a credential with an EL authorization.

Integrated ELD

ELs in the SEI program also receive integrated ELD in grade-level core content area classes. According to the CA ELD Framework, integrated ELD is defined as instruction "in which all teachers with ELs in their classrooms use the CA ELD standards in tandem with the focal California Common Core State Standards for ELA/Literacy and other content standards" (CA ELD Standards, 9). In integrated ELD, classroom teachers also use SDAIE strategies to support English learners. Core content area teachers who teach English learners must also be fully-credentialed with an EL authorization.

Section 3

Program Opt-Out

Per federal guidelines, parents of English learners have the right to opt their child out of participating in the ELD program. Should a parent wish to opt out their English learner, MCS will respect the wishes of the parent. To opt your child out of an ELD program, please contact the Director II of English Learner Services. Although the student will not participate in the District's ELD program, they will still maintain their status as an English learner. Per state law, the district has an obligation to continue monitoring the student's academic progress. Students who have been opted-out of the ELD program must still take the Summative ELPAC at the end of each academic year in order to monitor their English language proficiency (5 CCR § 11306).

Elementary English Language Development Grades K-6

Elementary Program Structure

At the elementary level, ELs receive integrated and designated ELD instruction within their class with their classroom teacher, another grade level teacher, or through push-in or pull-out models. Each EL student receives daily protected designated ELD instruction. Only English learners receive designated ELD instruction.

Elementary Program Placement

How to Access Elementary EL Data for Placement and Instruction

Teachers have access to EL assessment data through MOSIS and PowerSchool. Using these resources, all teachers are expected to familiarize themselves with their ELs' language proficiency levels and intentionally align ELD instruction to the language needs of the students. Teachers will support the language development of ELs in the regular classroom through integrated ELD instruction by practicing SDAIE strategies.

Section 3

| English Learner Placement for Elementary Students (K-3) | | |
|--|--|---|
| Years in the U.S. | 0-12 months | 1+ years |
| Core Content | <ul style="list-style-type: none"> • ELA : Wonders • Math: <i>SWUN</i> • Science: Discovery Science CA • History: Studies Weekly | <ul style="list-style-type: none"> • ELA: Wonders • Math: <i>SWUN</i> • Science: Discovery Science CA • History: Studies Weekly |
| Designated ELD | <ul style="list-style-type: none"> • Wonders ELD | <ul style="list-style-type: none"> • Wonders ELD |
| Designated ELD delivery | <ul style="list-style-type: none"> • Grade level teacher provides designated time • Teacher has CLAD/CTEL • With structured supports | <ul style="list-style-type: none"> • Grade level teacher provides designated time • Teacher has CLAD/CTEL • With structured supports |
| ELPAC | <ul style="list-style-type: none"> • ELPAC 1 | <ul style="list-style-type: none"> • ELPAC 1-4 |
| SPED | <ul style="list-style-type: none"> • IEP language goals etc. determines placement | <ul style="list-style-type: none"> • IEP language goals etc. determines placement |

| English Learner Placement for Elementary Students (4-6) | | |
|--|--|---|
| Years in the U.S. | 0-12 months | 1+ years |
| Core Content | <ul style="list-style-type: none"> • ELA : Wonders • Math: <i>SWUN</i> • Science: Discovery Science CA • History: Studies Weekly | <ul style="list-style-type: none"> • ELA: Wonders • Math: <i>SWUN</i> • Science: Discovery Science CA • History: Studies Weekly |
| Designated ELD | <ul style="list-style-type: none"> • Direct Instruction Spoken English (DISE) | <ul style="list-style-type: none"> • Wonders ELD |
| Designated ELD delivery | <ul style="list-style-type: none"> • Deploy to another teacher • Teacher has CLAD/CTEL • With structured supports | <ul style="list-style-type: none"> • Grade level teacher provides designated time • Teacher has CLAD/CTEL • With structured supports |
| ELPAC | <ul style="list-style-type: none"> • ELPAC 1 | <ul style="list-style-type: none"> • ELPAC 1-4 |
| SPED | <ul style="list-style-type: none"> • IEP language goals etc. determines placement | <ul style="list-style-type: none"> • IEP language goals etc. determines placement |

Section 3

Secondary English Language Development Grades 7-12

Secondary Program Structure

At the secondary level, ELs receive integrated and designated ELD instruction within the school day. Each EL student receives integrate ELD within all core contents- English Language Arts, Mathematics, Science, and Social Science. Although there are different pathways for students receiving designated ELD, each EL student receives daily protected designated ELD instruction. Only English learners receive designated ELD instruction.

Secondary Program Placement

| English Learner Placement for Secondary Students (7-8) | | |
|---|---|---|
| Years in the U.S. | 0-12 months | 1+ years |
| Core Content | <ul style="list-style-type: none"> • ELA: Adopted Curriculum • Math: SWUN • Science: Discovery Science CA • History: McDougal | <ul style="list-style-type: none"> • ELA: StudySync • Math: SWUN • Science: Discovery Science CA • History: McDougal |
| Designated ELD | <ul style="list-style-type: none"> • Adopted Curriculum | <ul style="list-style-type: none"> • StudySync ELD |
| Designated ELD delivery | <ul style="list-style-type: none"> • Teacher has CLAD/CTEL • With structured supports | <ul style="list-style-type: none"> • Grade level teacher provides designated time • Teacher has CLAD/CTEL • With structured supports |
| ELPAC | <ul style="list-style-type: none"> • ELPAC 1 | <ul style="list-style-type: none"> • ELPAC 1-4 |
| SPED | <ul style="list-style-type: none"> • IEP language goals etc. determines placement | <ul style="list-style-type: none"> • IEP language goals etc. determines placement |



Section 3

| English Learner Placement for Secondary Students (9-12)* | | |
|---|--|---|
| Years in the U.S. | 0-12 months | 1+ years |
| Core Content | <ul style="list-style-type: none"> • System 44 • Grade-level Math • Grade-level Science • Grade-level Social Science | <ul style="list-style-type: none"> • ELA: StudySync • Grade-level Math • Grade-level Science • Grade-level Social Science |
| Designated ELD | <ul style="list-style-type: none"> • Every Day English Plus | <ul style="list-style-type: none"> • Edge (Fundamentals, A, B, or C) |
| Designated ELD delivery | <ul style="list-style-type: none"> • Teacher has CLAD/CTEL • With structured supports | <ul style="list-style-type: none"> • Grade level teacher provides designated time • Teacher has CLAD/CTEL • With structured supports |
| ELPAC | <ul style="list-style-type: none"> • ELPAC 1 | <ul style="list-style-type: none"> • ELPAC 1-4 |
| SPED | <ul style="list-style-type: none"> • IEP language goals etc. determines placement | <ul style="list-style-type: none"> • IEP language goals etc. determines placement |

| <u>9-12 Designated ELD Class</u> | Designated ELD Initial Placement Guidelines* |
|---|---|
| <u>Academic Language Development Fundamentals</u> | <u>ELPAC Overall 1</u> |
| Academic Language Development A | ELPAC Overall 1/2 |
| Academic Language Development B | ELPAC Overall 3/4 |
| Academic Language Development C | ELPAC Overall 4 |

*These are guidelines - actual placement is determined by number of ELs and their overall scores.

Section 3

How to Access Secondary EL Data for Placement and Instruction

Teachers have access to EL assessment data through MOSIS and PowerSchool. Using these resources, all teachers are expected to familiarize themselves with their ELs' language proficiency levels. Teachers will support the language development of ELs in the regular classroom through integrated ELD instruction by practicing SDAIE strategies.

Supporting English Learners

Supporting English Learners who are At-Risk LTELs or LTELs

MCS distributes data reports for students that are At-Risk LTELs or LTELs on a monthly basis to key stakeholders (site administrators, counselors, instructional coaches, etc.). Data is disaggregated in order to activate the multi-tiered system of support (MTSS), school study teams (SSTs), and other site based supports and interventions.

Supporting English Learners' Access to Advanced Courses & Gifted and Talented Programs

MCS believes all students, including English learners, will have equitable access to advanced courses and programs such as Advanced Placement (AP), Gifted and Talented Education (GATE), and International Baccalaureate (IB), as well as Career Technical Education Pathways (CTE). MCS will ensure that English learners are not overlooked for these programs and courses because of a lack of English language proficiency. In 2nd grade, all students are tested for GATE; for students in all other grades wishing to participate in GATE, parents may fill out a referral for testing. Students who are identified as GATE receive differentiated instruction in their classes and may also receive GATE services through a cluster grouping model at their school site. English learners who are also identified as GATE will continue to receive ELD services to support their English language acquisition, while also receiving differentiated instruction to meet their needs as a gifted and talented learner.

At the middle and high school level, all students, including English learners, have equal access to advanced courses such as AP classes, CTE pathways, or the IB program. All English learners, regardless of their participation in advanced programs and courses, will continue to receive English language development instruction until they meet the criteria for reclassification. For more information about AP, IB, GATE, or CTE, please contact the District Office.

Section 3

Supporting English Learners with IEPs or 504 Plans

English learner services for students with IEPs or 504 Plans will be determined by the student's IEP team.

Accountability

Elementary Program Monitoring

The site principal is responsible for leading and monitoring the implementation of ELD scheduling, grouping, and instruction at their site. Administrators will work with the grade level and/or department teams to analyze student assessments and modify instruction as necessary.

Secondary Program Monitoring

The site principal is responsible for leading and monitoring the implementation of ELD programs and instruction at their site. Administrators will work with the ELD teachers, counselors, and grade level and/or department teams to analyze student assessments and modify instruction as necessary.

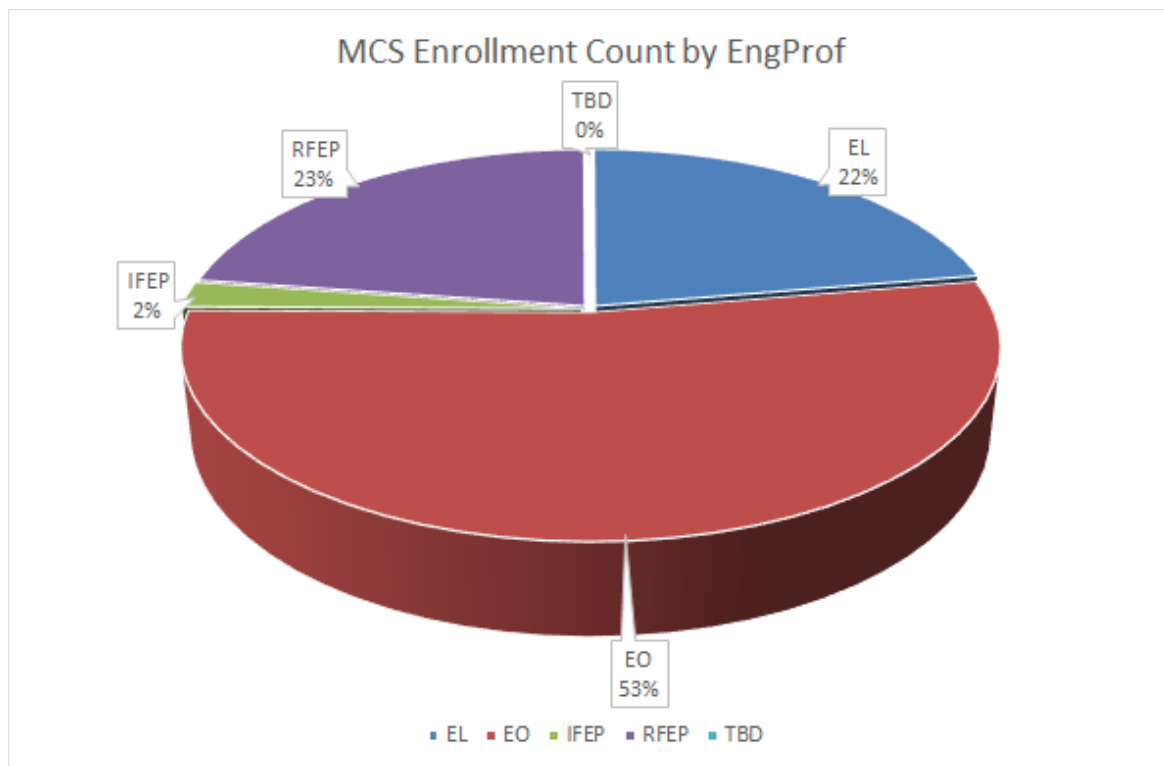

Section 4

Instructional Practices & Professional Development

MCS strongly believes all English learners enter the District with a valuable asset – oral proficiency in a language other than English. The goal of ELD instruction is to build fluency in English, while still honoring the value of the student's primary language. Our goal is to build students' English language proficiency, not at the expense of their primary language, but in addition to it, so that our English learners have the opportunity to become bilingual, bicultural, and biliterate individuals.

Instructional Practices

2012 California English Language Development Standards

Following the adoption and implementation of the Common Core State Standards for California, the California State Board of Education adopted a new set of English Language Development standards. These standards are used as the primary tools for lesson design and instruction in the District's English Language Development program. The 2014 California ELD Framework identifies three key goals for English learners:

- Develop readiness for college, career, and civic life
- Attain the capacities of literate individuals
- Become broadly literate

The following key themes from the CA ELD Framework support these goals:

- Meaning making
- Effective expression
- Foundational skills
- Content knowledge
- Language development

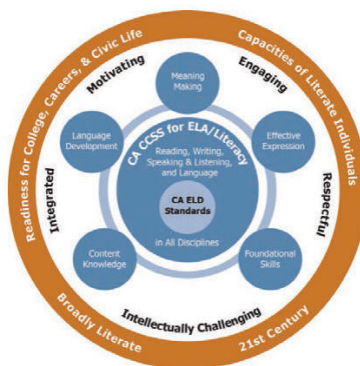

Section 4

The CA ELD standards work in tandem with the Common Core State Standards for English Language Arts and Literacy (CCSS ELA/Literacy). The CCSS ELA/Literacy reflect a fundamental shift in English language development instruction – the belief that all content area teachers are also literacy teachers. According to the CCSS, "Meeting the demands of the literacy standards requires substantially expanding the literacy requirements in history/social science, as well as in science and technical subjects." As a result of this shift, language development can be supported through academic discourse in a math classroom, a historical debate, or an argumentative essay centering around a scientific theory. In addition to the language skills taught through language arts curriculum, students develop their reading, writing, speaking, listening, and critical thinking skills in all content areas. The fundamental belief that all teachers are literacy teachers means all MCS students, particularly English learners, are given multiple opportunities each day to develop and sharpen the literacy skills needed to become productive, global citizens. While all teachers are expected to align their instruction to the CCSS for ELA/Literacy, all teachers who have ELs in their classrooms are also expected to incorporate the 2012 CA ELD standards in their daily lessons.

The following key themes from the CA ELD Framework support these goals:

- Meaning making
- Effective expression
- Foundational skills
- Content knowledge



ELD Standards: Parts I, II, III

The ELD standards are divided into three parts: Interacting in Meaningful Ways, Learning About How English Works, and Using Foundational Literacy Skills . The following details the three parts:

Part I Interacting in Meaningful Ways

A. Collaborative

1. Exchanging information and ideas with others through oral collaborative conversations on a range of social and academic topics
2. Interacting with others in written English in various communicative forms (print, communicative technology, and multimedia)

Section 4

- 3. Offering and supporting opinions and negotiating with others in communicative exchanges
- 4. Adapting language choices to various contexts (based on task, purpose, audience, and text type)

B. Interpretive

- 5. Listening actively to spoken English in a range of social and academic contexts
- 6. Reading closely literary and informational texts and viewing multimedia to determine how meaning is conveyed explicitly and implicitly through language
- 7. Evaluating how well writers and speakers use language to support ideas and opinions with details or reasons depending on modality, text type, purpose, audience, topic, and content area
- 8. Analyzing how writers and speakers use vocabulary and other language resources for specific purposes (to explain, persuade, entertain, etc.) depending on modality, text type, purpose, audience, topic, and content area

C. Productive

- 9. Expressing information and ideas in formal oral presentations on academic topics
- 10. Composing/writing literary and informational texts to present, describe, and explain ideas and information, using appropriate technology
- 11. Supporting own opinions and evaluating others' opinions in speaking and writing
- 12. Selecting and applying varied and precise vocabulary and language structures to effectively convey ideas

Part II Learning About How English Works

A. Structuring Cohesive Texts

- 1. Understanding text structure
- 2. Understanding cohesion

B. Expanding and Enriching Ideas

- 3. Using verbs and verb phrases
- 4. Using nouns and noun phrases
- 5. Modifying to add details



Section 4

C. Connecting and Condensing Ideas

6. Connecting ideas

7. Condensing ideas

Part III Using Foundational Literacy Skills

ELD Proficiency Levels

The ELD standards are divided into three language proficiency levels: Emerging, Expanding, and Bridging . The following proficiency level descriptors are provided in the 2012 CA ELD Standards:

- **Newcomer** students are those English learners who have been in the United States for less than 12 months. These students come to school possessing a wide range of competencies in their primary language appropriate to their age. They may have varying levels of literacy depending on their prior experiences in the home, community, and at school. As learners of English as a new language, they gain metacognitive awareness of what language is and how it is used and apply this awareness in their language learning strategies, including drawing upon their native language. Newcomers possess cognitive abilities appropriate to their age and experience, but they require high levels of linguistic support in order to communicate their thinking.
- **Emerging ELs** typically progress very quickly, learning to use English for immediate needs as well as beginning to understand and use academic vocabulary. These students require substantial scaffolding and support in order to engage in grade-level tasks and activities as well as specialized ELD instruction.
- **Expanding ELs** are challenged to increase their English skills in more contexts, and learn a great variety of vocabulary and linguistic structures, applying their growing language skills in more sophisticated ways appropriate to their age and grade level. These students require moderate scaffolding and support in order to engage in grade-level tasks and activities, as well as some specialized ELD instruction.



Section 4

- **Bridging ELs** continue to learn and apply a range of high-level English language skills in a wide variety of contexts. These students are transitioning to full engagement in grade-level tasks and activities, without the need for specialized ELD instruction.

High-Impact Instructional Strategies for Designated and Integrated ELD

Along with utilizing ELD standards, teachers in both an integrated and designated ELD class, utilize research-based best practices. The following are three examples of best practices for English learners: a learning target aligned to a language skill, regular academic discourse, and student responses in complete sentences.

- **Learning target aligned to a language skill:** After strategically planning lessons backwards mapped from an instructional outcome, learning targets with a language skill should be created for each daily lesson. This practice dramatically increases student learning, as students know what skills they are learning during a lesson and whether or not they have successfully mastered the skill. In addition, a learning target keeps the teacher's instruction aligned to an overall goal, and formative assessments can be given in order to adjust instruction as students progress. According to Hill and Miller, in their book Classroom Instruction that Works with English Language Learners (2014), "Setting objectives in the classroom helps focus the direction for learning and the path for teaching."
- **Academic discourse:** Teachers should assign regular partners for their students; for ELs in a designated ELD class, partnering students with someone who is at a similar language level is ideal, so that they can be pushed linguistically while still receiving some primary language support from their peer(s) as needed. Students should be doing at least 50% of the talking during every lesson. Engaging all students in academic conversation is key. According to Hill and Miller (2014), "Teachers of students learning English and other subjects in need of language development can develop language as well as subject-matter knowledge and skills by providing opportunities for students to engage in meaningful opportunities related to specific content ... " (29). To accelerate students' language capacities, give them regular and intentional opportunities to speak.
- **Complete sentences:** Students should respond in complete sentences the majority of the time. This accomplishes several things for ELs: it builds their ear for academic English, increases their use of academic vocabulary, reinforces the content being taught, and builds capacity for more complex language structures, which carries over to their writing. Providing sentence frames or sentence starters can give scaffolds for students to produce longer and more complex sentences. Newcomers may need more

Section 4

scaffolded sentence frames or may also need to repeat a model sentence in order to achieve this goal. According to Achievethecore.org, "English Language Learners (ELLs) can benefit early on in their English development from sentence frames/starters to help them understand the type of content they are being asked to talk or write about. Sentence frames help students who are new to English by providing vocabulary and structure that they wouldn't be able to produce on their own. Sentence frames are particularly helpful when writing about more linguistically complex ideas." Speaking in complete sentences with the scaffolds of sentence frames assists students in acquiring academic English.

What is Specifically Designed Academic Instruction in English?

All teachers with English learners in their classroom are expected to practice SDAIE strategies to support integrated ELD instruction. SDAIE, or Specifically Designed Academic Instruction in English, is a set of instructional tools that support the acquisition of English language proficiency in any content area. These research-based methods benefit not only English learners, but all students as they develop their academic language capacity. Below is a sample of high-impact SDAIE strategies:

- Learning targets with a language focus and feedback aligned to the target
- Student-centered cooperative learning
- Academic conversations
- Targeted vocabulary instruction
- Visual-aids and manipulatives
- Accessing prior knowledge
- Graphic organizers and thinking maps



Professional Development

MCS provides staff with professional development around ELD instruction. The Director II of English Learner Services provides ELD training and coaching to all designated ELD teachers. In this training, teachers receive research-based resources and effective strategies for teaching designated ELD. In addition, SDAIE training and coaching is provided to groups of high school English Language Arts and other content area teachers. Possible topics addressed in professional development for ELD include, but are not limited to:

Section 4

- 2012 CA ELD Standards
- 2014 CA ELA/ELD Framework
- 2013 Next Generation Science Standards for California Public Schools
- 2010 The College and Career Readiness Anchor Standards for ELA and Literacy
- 2013 Mathematics Framework
- Initial & Summative ELPAC
- High-impact instructional strategies for designated ELD
- High-impact instructional strategies for integrated ELD/SDAIE
- Identifying ELs using the District student information portal and Data Warehouse
- Analyzing EL assessment data

MCS has a team of highly-qualified instructional coaches who provide job-embedded coaching to classroom teachers K-12. In a job-embedded coaching cycle, an instructional coach works closely with a classroom teacher and their students toward an agreed-upon student-centered goal. Using data from formative assessments, the coach and the teacher make instructional decisions to help students achieve the learning goal. At times, the coach may also micro-model specific instructional strategies that will support the students and the teacher in their learning. Instructional Coaches, who are part of the instructional coaching team, work specifically with teachers throughout MCS to support teachers in instructional strategies for English learners in both designated and integrated ELD.

English Learners' Primary Languages

Spanish is the primary language of over **90%** of the English Learners in Modesto City Schools. The chart at right shows the other primary languages spoken by English Learners in our district. Arabic and Khmer are the next largest, at 1.6% followed by Farsi at 1.4%.

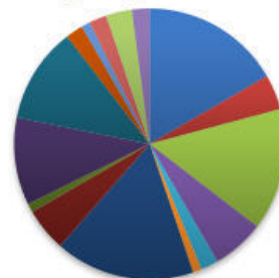

- | | | |
|---------------------|------------|------------------------|
| ■ Arabic | ■ Assyrian | ■ Farsi (Persian) |
| ■ Hindi | ■ Hmong | ■ Japanese |
| ■ Khmer (Cambodian) | ■ Lao | ■ Mandarin (Putonghua) |
| ■ Other non-English | ■ Pashto | ■ Pilipino (Tagalog) |
| ■ Portuguese | ■ Punjabi | ■ Russian |
| ■ Vietnamese | | |

Section 5

Reclassification

Reclassification

English Learners will be reclassified as Redesignated Fluent English Proficient (R-FEP) status when they demonstrate the skills necessary to compete equally with average native English speaking students.

Reclassification Criteria*

Per state and district guidelines (EC 313(f), 5 CCR § 11303), the Assessment Center will begin the reclassification process when an English Learner has met all the following criteria:

1. Current year Overall ELPAC score of (4) Well Developed
2. Teacher evaluation
3. Parent consultation
4. Comparison of student performance in state-adopted English Language Arts reading and writing standards through an objective assessment tool such as the state test for English Language Arts

*See attached Reclassification Criteria

Reclassification Process

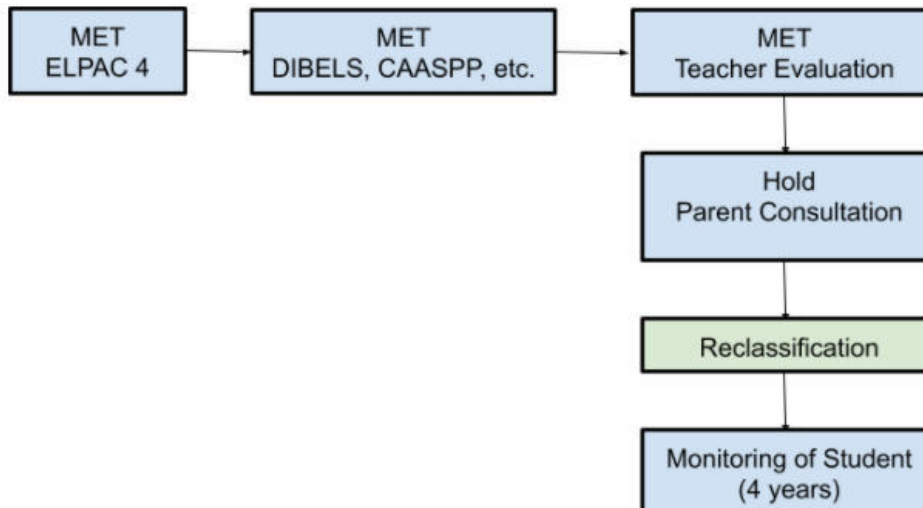

Section 5

Step 1: The Assessment Center analyzes assessment data and identifies ELs eligible for reclassification. ELs who meet the reclassification criteria based on assessment data alone will continue the reclassification process in Step 3. If a grade level does not use an assessment, such as CAASPP, the Assessment Center will continue the reclassification process outlined in Step 2.

Step 2: For those without a CAASPP score, the Assessment Center will provide an assessment that is aligned to grade-level language arts standards. The site is responsible for administering the assessment to each student and returning the completed scores to the Assessment Center.

Step 3: If an English learner meets the reclassification criteria, the Assessment Center will contact the site, who will then complete the reclassification process with the student's parent/guardian, a classroom teacher, and the site administrator. For all forms related to reclassification, please see attached.

Step 4: Once the reclassification paperwork has been completed, the Assessment Center will change the student's English Learner (EL) status to Redesignated Fluent English Proficient (R-FEP).

Reclassification Monitoring

Annually, the Assessment Center will provide the RFEP Monitoring Form to the site administrator to analyze student data including, but not limited to, academic progress grades, attendance, and behavior. If any concerns emerge in the data, the site administrator will contact the classroom teacher(s) for additional insight as to the student's progress. If it is determined that the student requires additional support and/or interventions, the student's counselor will meet with the reclassified student to discuss the student's needs and establish goals together.

Reclassification for Students who are Eligible for Alternative Reclassification

Some students with disabilities may be eligible for alternative reclassification, dependent upon their IEP. For more information about the alternative reclassification process, please contact the Administrator of Special Projects.

Section 5

State Seal of Biliteracy



State Seal of Biliteracy Requirements

In order to affirm the value of bilingualism and encourage our students' enrollment in world language programs, the state of California awards the State Seal of Biliteracy (SSB) to graduating students who have demonstrated biliteracy in English and at least one other language. Graduating seniors within Modesto City Schools who meet the state requirements for biliteracy will earn the State Seal of Biliteracy. Students must meet the current California Department of Education State Seal of Biliteracy requirements.

Eligibility Criteria for a Student Whose Primary Language is English

Each of these three academic requirements shall be fulfilled:

1. Students must have completed all English-language arts (ELA) requirements for graduation with an overall grade point average (GPA) of 2.0 or above in those classes.
2. Students must have passed the California Assessment of Student Performance and Progress (CAASPP) in ELA (administered in grade eleven), or any successor test, administered in grade eleven, at or above the “standard met” achievement level, or at the achievement level determined by the State Superintendent of Public Instruction (SSPI) for any successor test.
3. Students must demonstrate proficiency in one or more languages other than English through one of the following methods:
 - Pass a foreign language Advanced Placement (AP) exam, including American Sign Language, with a score of three or higher.
 - Pass an International Baccalaureate (IB) examination with a score of four or higher.
 - Successfully complete a four-year high school course of study in a foreign language and attain an overall grade point average of 3.0 or above in that course of study, and demonstrate oral proficiency in the language comparable to that required to pass an AP or IB examination.

Section 5

- If no AP examination or off-the-shelf language test exists and the district uses its own language examination, the school district must certify to the SSPI that the test meets the rigor of a four-year high school course of study in that foreign language and, at a minimum, assesses speaking, reading, and writing. If a student seeks to qualify for the SSB through a language that is not characterized by listening, speaking, or reading, or for which there is no written system, the student must pass an assessment on the modalities that characterize communication in that language at the proficient level or higher.
- If a district offers a language examination in a language in which an AP examination or off-the-shelf examination exists, the district language examination must be approved by the SSPI.
- Pass the Scholastic Assessment Test (SAT) II foreign language exam with a score of 600 or higher.

Eligibility Criteria for a Student Whose Primary Language is not English

If the primary language of a pupil is other than English, the student shall also meet the following academic requirements:

1. Attain the level demonstrating English language proficiency on the English Language Proficiency Assessments for California (ELPAC), or any successor English language proficiency assessment, in transitional kindergarten or kindergarten through grade twelve, inclusive.
2. Meet the academic requirements 1, 2, and 3 as stated above in Section I.

Benefits of Earning the State Seal of Biliteracy

The Seal of Biliteracy recognizes and promotes world language instruction in public schools and encourages students to study world languages. Earning the Seal provides students with a competitive edge as they move on to careers and higher education. In addition, promoting biliteracy in multiple languages honors the cultures and languages of our community and leads to an appreciation of the diversity in our schools.

Section 6

Parent Advisory Committees

The Board of Education is the local governing entity for MCS. In addition, the District has a regular District English Learner Advisory Committee (DELAC) meeting. This committee shares district-wide data, events, and parent learning workshops with parents and community members as well as mandated training topics required by the State of California. Sites have an English Learner Advisory Committee (ELAC)/English Learner Parent Partnership (ELPP), that focuses on site-based programs, data, and supports for ELs. The relationship between DELAC and ELPP is crucial for communication and coherence throughout MCS as it pertains to our ELs.

English Learner Advisory Committee (ELAC)

State law requires any school site with 21 or more ELs to establish an ELAC and hold ELAC meetings (5 CCR § 11308(a)). The site administrator is responsible for establishing the Committee. The ELAC provides parents of ELs an opportunity to give input on site-based English learner services and focuses on site-based programs, data, and supports for English learners. The ELAC is an advisory council, not a decision-making body. The Committee advises the principal on services and programs for ELs, assists in the development of the school's needs assessment, and informs parents of the importance of regular school attendance. The ELAC receives training and any necessary materials, planned in full consultation with committee members, to assist members in carrying out their legal responsibilities. The ELAC serves as the voice of the EL community.

Requirements

The law states that parents of English learners must comprise at least the same percentage of ELAC membership as the percentage of ELs enrolled at the school site. For example, if 30% of the school's total student population are ELs, at least 30% of the ELAC members must be parents of English learners. Other parents/guardians, staff, and community members may be ELAC members as long as the percentage of EL parents matches or exceeds the percentage of EL students at the school.

Section 6

Elections

By law, all parents of English learners must have the opportunity to elect parent members to the English Learner Advisory Committee. In addition, the ELAC has the responsibility to elect one of their members to attend DELAC meetings. If a member of ELAC is not elected, the chair must attend the DELAC meetings. The ELAC bylaws, or if absent, the DELAC bylaws, shall determine additional election procedures and requirements.

Guidelines

The number of ELAC meetings per year is established by the ELAC bylaws, or when absent, the DELAC bylaws. The following required topics must be discussed at the ELAC meetings:

- promoting regular school attendance
- development of the Needs Assessment
- advising the School Site Council (SSC) on the School Plan for Student Achievement (SPSA)
- advising the principal and staff on the site program and services for English Learners and its objectives and goals
- reclassification procedures

In addition, the following suggested topics are appropriate for discussion at an ELAC meeting:

- ELAC’s legal responsibilities
- ELD Standards
- State Seal of Biliteracy
- Common Core State Standards
- Initial and Summative ELPAC
- Other topics related to student academic and emotional development



Section 6

District English Learner Advisory Committee (DELAC)

By law, districts serving 50 or more English learners must establish a District English Learner Advisory Committee (5 CCR§ 11308(a), EC 52069(b)(1)). This committee shares District-wide data, events, and parent learning workshops with parents and community members as well as mandated training topics required by the State of California. District SLS is responsible for establishing a DELAC meeting calendar, holding DELAC elections, distributing DELAC notices, and facilitating DELAC meetings. With the consultation of committee members, the District will provide training and any necessary materials needed to assist members in carrying out their legal advisory responsibilities.

Requirements

The law requires that the parents/guardians of English learners, who are not employed by the District, constitute the majority (51 %) of the DELAC. In addition, other parents/guardians, community members, and district staff may also participate in DELAC. The DELAC bylaws may establish additional requirements.

Meetings

Notice for DELAC meetings must be posted at least 72 hours in advance of the scheduled meeting time (EC 35147(c)(1)). All DELAC meetings must follow the Brown Act and Robert's Rules of Order (EC § 5147(a)). During the meeting, parents, community members, and staff have an opportunity to provide input on English learner services in the district.

The committee advises MCS's governing board on the following topics:

- developing the District master plan for educational programs and services for ELs
- conducting a District-wide needs assessment on a school-by-school basis
- establishing District goals and objectives for programs and services for ELs
- developing a plan to ensure compliance with applicable teacher and/or teacher aide requirements
- reviewing and commenting on:
 - the school district reclassification procedures
 - written notifications required to be sent to parents and guardians
 - the development or annual update of the Local Control and Accountability Plan (LCAP)

Appendices

| | |
|---|--|
| <p>2020-2021 Modesto City Schools Program Options for Language Acquisition Grades KN – 6</p> | |
| <p>If interested in these or other language programs or for more information, please call the Assessment Center at 574-1590 or the school.</p> | |
| <p>Goal: For all English Learners (EL) to become proficient in English and grade level standards in all subjects, as measured by the English Language Proficiency Assessment for California (ELPAC) and grades.</p> | |
| Program | Structured English Immersion (SEI) |
| Goal | English fluency |
| Location & For Whom | All Sites English Learners |
| Program Description | <p>Instruction is primarily in English. Instruction is specially designed to support the English Learner's ability to meet grade level standards while in the process of becoming proficient in English. Core content instruction is based on state grade level standards and teachers utilize appropriate strategies to ensure comprehensibility of instruction.</p> |
| Designated ELD Materials | K-6: Wonders |
| Integrated ELD Materials | <p>English Language Arts: K-6: Wonders Spanish Language Arts: K-6: Maravillas Mathematics: K-6: SWUN Science: K-6: Discovery Science CA Social Science: K-6: McDougal</p> |
| | Dual Language Academy (DLA) |
| | <p>Parent choice program for English Learners and English fluent students</p> |
| Goal | Specialized program to attain bilingualism and biliteracy in both English and Spanish |
| Location & For Whom | Bret Harte Elementary English Learners and English fluent students Contact the Assessment Center at 574-1590 for information regarding enrollment in this program. |
| Program Description | <p>Instruction is in English 50% and Spanish 50% each day in each grade. The DLA uses a 50-50 model, in which daily instruction is 50% in English and 50% in Spanish and requires a specific application process. Entry into the DLA in grades K-1 is open based on space availability; grades 2-6 the student must meet minimum oral, reading, and writing proficiency requirements in both English and Spanish to ensure the student's academic success in the DLA.</p> |
| Designated ELD Materials | K-6: Wonders |
| Integrated ELD Materials | <p>English Language Arts: K-6: Wonders Spanish Language Arts: K-6: Maravillas Mathematics: K-6: SWUN Science: K-6: Discovery Science CA (Spanish) Social Science: K-6: McDougal (Spanish)</p> |

Appendices

Modesto City Schools 2020-2021 Program Options for Language Acquisition Grades 7-12

If interested in these or other language programs or for more information, please call the Assessment Center at 574-1590 or the school.

Goal: For all English Learners (EL) to become proficient in English and grade level standards in all subjects, as measured by English Language Proficiency Assessments for California (ELPAC) and grades.

| Program | Structured English Immersion (SEI) | Dual Language Academy (DLA) | Newcomer Program (Language Institute) |
|---------------------------------|---|--|--|
| Goal | English fluency | Bilingualism and biliteracy in both English and Spanish | English acquisition as rapidly and effectively as possible |
| Location & For Whom | All Sites English Learners | Hanshaw Jr High English Learners and English fluent students Contact the Assessment Center at 574-1590 for information regarding enrollment in this program. | Roosevelt Jr High & Davis High English Learner with less than 12 months of U.S. schooling Contact the Assessment Center at 574-1590 for information regarding enrollment in this program. |
| Program Description | Instruction is primarily in English. Instruction is specially designed to support the English Learner's ability to meet grade level standards while in the process of becoming proficient in English. Core content instruction is based on state grade level standards, and teachers utilize appropriate strategies to ensure comprehensibility of instruction. | Instruction is in English and Spanish daily. DLA at Jr. High provides continued development in English and Spanish language and literacy. Students in Jr. High DLA receive Spanish Social Studies, Spanish language arts, English language arts, Math, Science, P.E. and elective classes. Entry into DLA requires a specific application process. Student must meet minimum oral, reading, and writing proficiency requirements in both English and Spanish to ensure the student's academic success in the DLA. | Instruction is primarily in English. Instruction is specially designed to ensure English acquisition as rapidly and effectively as possible while also providing access to core content classes. Core content instruction is based on state grade level standards, and teachers utilize appropriate strategies to ensure comprehensibility of instruction. |
| Designated ELD Materials | 7-8: StudySync ELD 9-12: Cengage Edge | 7-8: StudySync ELD 9-12: Cengage Edge | 7-8: StudySync ELD 9-12: Cengage Edge |
| Integrated ELD Materials | English Language Arts: 7-8: StudySync ELA 9-12: StudySync ELA Mathematics: 7-8: SWUN 9-12: Pearson enVision Science: 7-8: Discovery Science CA 9-12: Discovery Science CA Social Science: 7-8: McDougal 9-12: McDougal | English Language Arts: 7-8: StudySync ELA 9-12: StudySync ELA Mathematics: 7-8: SWUN 9-12: Pearson enVision Science: 7-8: Discovery Science CA 9-12: Discovery Science CA Social Science: 7-8: McDougal 9-12: McDougal | Newcomer Curriculum: System 44 and Every Day English Plus English Language Arts: 7-8: StudySync ELA 9-12: StudySync ELA Mathematics: 7-8: SWUN 9-12: Pearson enVision Science: 7-8: Discovery Science CA 9-12: Discovery Science CA Social Science: 7-8: McDougal 9-12: McDougal |

Appendices

Modesto City Schools: Grades K-12 2020-2021 Reclassification Criteria

Revised 7/7/20

| Grade Level | English Proficiency | Basic Skills in English Language Arts | Teacher Evaluation | Parent Input & Notification |
|-------------|---|---|--|-----------------------------|
| K | Summative ELPAC Level 4 (Well Developed) | DIBELS Grade level benchmark | Report Card Achievement level of 2 or higher in English Language Arts on Standards based report card | Required |
| 1-4 | Summative ELPAC Level 4 (Well Developed) | DIBELS Grade level benchmark | Report Card Achievement level of 2 or higher in English Language Arts on Standards based report card | Required |
| 5-9 | Summative ELPAC Level 4 (Well Developed) | ELA CAASPP | 5-6 Report Card Achievement level of 2 or higher in English Language Arts on Standards based report card 7-9 Report card grades C in ELA class OR Cumulative GPA of 2.0 | Required |
| 10-12 | Summative ELPAC Level 4 (Well Developed) | StudySync Grade level benchmark | Report card grades C in ELA class OR Cumulative GPA of 2.0 | Required |

All ELPAC and assessment data must be no more than one-year-old from reclassification form date.

Due to COVID-19, we may use data from the 18-19 school year to reclassify.